

Fig. 3. An application of the Rod with Keyway to form the drill spindle of a model drilling machine. By its use the spindle is free to rise and fall without interruption to the drive.

the Gear or Pinion turns with the Rod. Several applications of the Rod with Keyway are shown in the Gears Outfit "B" Instructions Book and three examples are shown in Figs. 2, 3 and 4 on these pages.

Fig. 2, from the Instructions Book, illustrates how to build with the gears in the Outfit a Twin Drive Unit that will be found useful in many models such as cranes, in which it is necessary to drive two separate movements from a single Motor. With this mechanism a drive can be transmitted to two shafts, either independently or together; and one of these shafts can be used to operate the hoisting movement of a crane, while the other controls raising and lowering of the jib.

The second mechanism, also taken from the

Instructions Book, shows how a drive can be transmitted to a Rod that must be free to slide in its bearings. This particular example is a drive to the shaft of a model drill, and shows how the Rod with Keyway and the Key Bolt enable the shaft to be raised or lowered without affecting the drive.

The gear-box for model vehicles shown in Fig. 4 has been designed as a further example of the way in which the new Rod with Keyway can be used with standard Meccano gears in the assembly of compact mechanisms of various kinds. This gear-box provides three forward speeds and a reverse drive, and it requires a few gears in addition to those contained in the Gears Outfit "B." It serves to illustrate how easily the new parts can be used not only with the parts in the Gears Outfit but with other parts in the Meccano System.

Referring to Fig. 4 the gear-box input shaft is a Rod 1 that carries a $\frac{1}{2}$ " Pinion in constant mesh with a 57-tooth Gear on a Rod with Keyway 2. The other gears on the Rod with Keyway are free to slide but they are made to turn with the Rod by Key Bolts screwed into their bosses. The sliding gears are grouped in pairs, and each pair is linked by connecting arms to a selector shaft. The sliding gears can be moved into mesh with corresponding gears on the output shaft 3. The movement of the selector shafts is controlled by the gear lever 4, which is universally mounted.

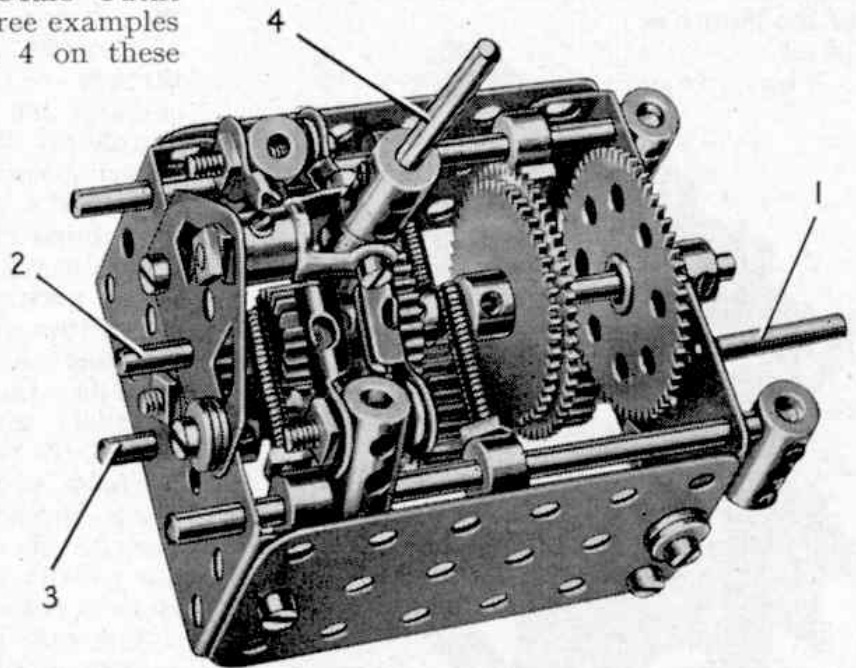

Fig. 4. One of the most useful applications of the Rod with Keyway is to be found in gear-boxes. It is used in this three-speed and reverse example, and helps in keeping it compact.

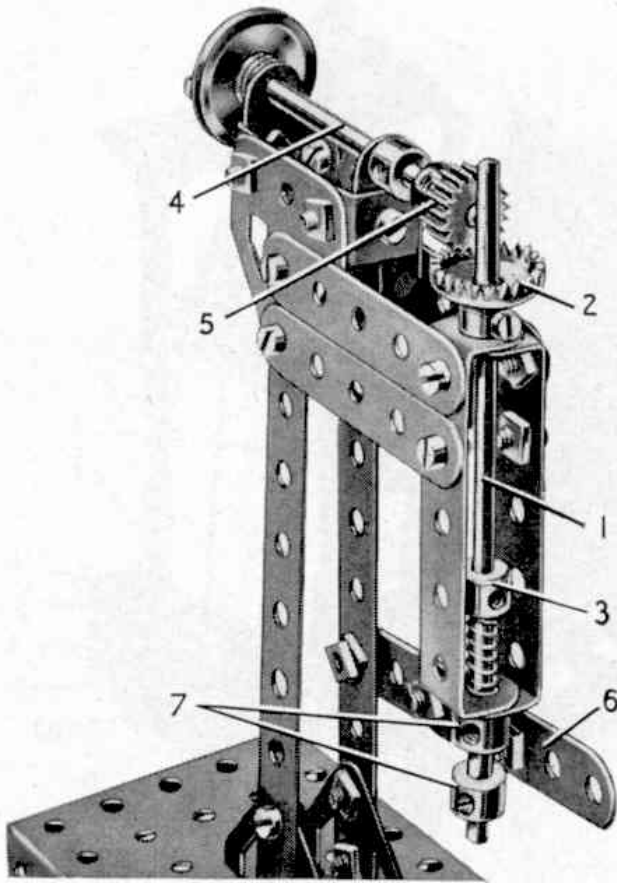

Fig. 3. An application of the Rod with Keyway to form the drill spindle of a model drilling machine. By its use the spindle is free to rise and fall without interruption to the drive.

the Gear or Pinion turns with the Rod. Several applications of the Rod with Keyway are shown in the Gears Outfit "B" Instructions Book and three examples are shown in Figs. 2, 3 and 4 on these pages.

Fig. 2, from the Instructions Book, illustrates how to build with the gears in the Outfit a Twin Drive Unit that will be found useful in many models such as cranes, in which it is necessary to drive two separate movements from a single Motor. With this mechanism a drive can be transmitted to two shafts, either independently or together; and one of these shafts can be used to operate the hoisting movement of a crane, while the other controls raising and lowering of the jib.

The second mechanism, also taken from the

Instructions Book, shows how a drive can be transmitted to a Rod that must be free to slide in its bearings. This particular example is a drive to the shaft of a model drill, and shows how the Rod with Keyway and the Key Bolt enable the shaft to be raised or lowered without affecting the drive.

The gear-box for model vehicles shown in Fig. 4 has been designed as a further example of the way in which the new Rod with Keyway can be used with standard Meccano gears in the assembly of compact mechanisms of various kinds. This gear-box provides three forward speeds and a reverse drive, and it requires a few gears in addition to those contained in the Gears Outfit "B." It serves to illustrate how easily the new parts can be used not only with the parts in the Gears Outfit but with other parts in the Meccano System.

Referring to Fig. 4 the gear-box input shaft is a Rod 1 that carries a $\frac{1}{2}$ " Pinion in constant mesh with a 57-tooth Gear on a Rod with Keyway 2. The other gears on the Rod with Keyway are free to slide but they are made to turn with the Rod by Key Bolts screwed into their bosses. The sliding gears are grouped in pairs, and each pair is linked by connecting arms to a selector shaft. The sliding gears can be moved into mesh with corresponding gears on the output shaft 3. The movement of the selector shafts is controlled by the gear lever 4, which is universally mounted.

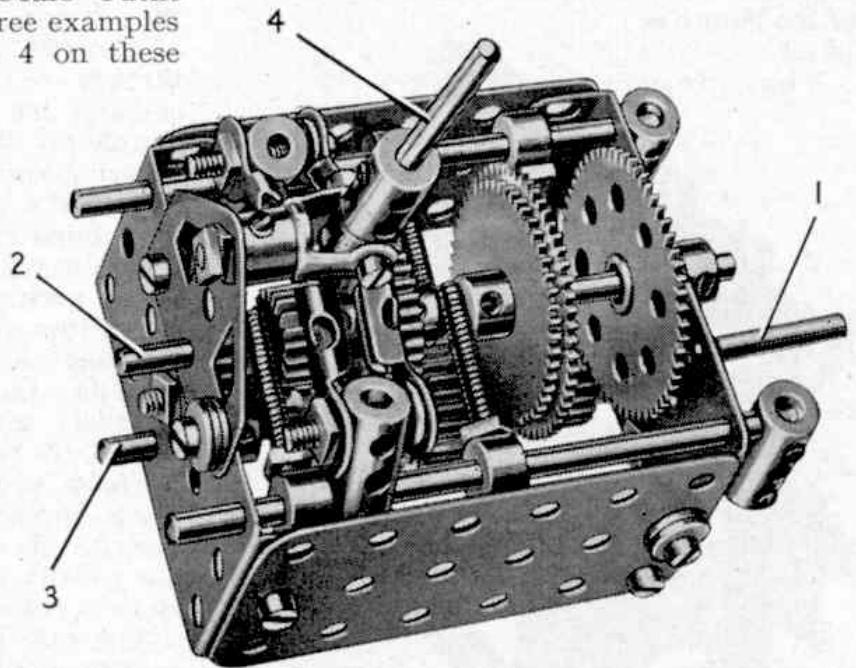

Fig. 4. One of the most useful applications of the Rod with Keyway is to be found in gear-boxes. It is used in this three-speed and reverse example, and helps in keeping it compact.

Among the Model- Builders

By "Spanner"

A Three-Speed and Reverse Gear-Box

The special article in the August issue of the *M.M.* announcing the new Gears Outfit 'B' included a picture of a gear-box that makes use of the Rod with Keyway, part No. 230. Since the picture appeared several readers have asked for further details of the gear-box, and this month I am including a full description of the mechanism, which is shown in Figs. 1 and 2.

The housing is made from two $3" \times 1\frac{1}{2}"$ Flat Plates connected by $2\frac{1}{2}" \times 1\frac{1}{2}"$ Flanged Plates, and a Flat Trunnion 5 is bolted to one end. It should be noted that Washers are placed next to some of the bolt heads as shown so that the shanks of the bolts clear the Gears and the Rods. The input shaft 1 is supported in one end of the housing and

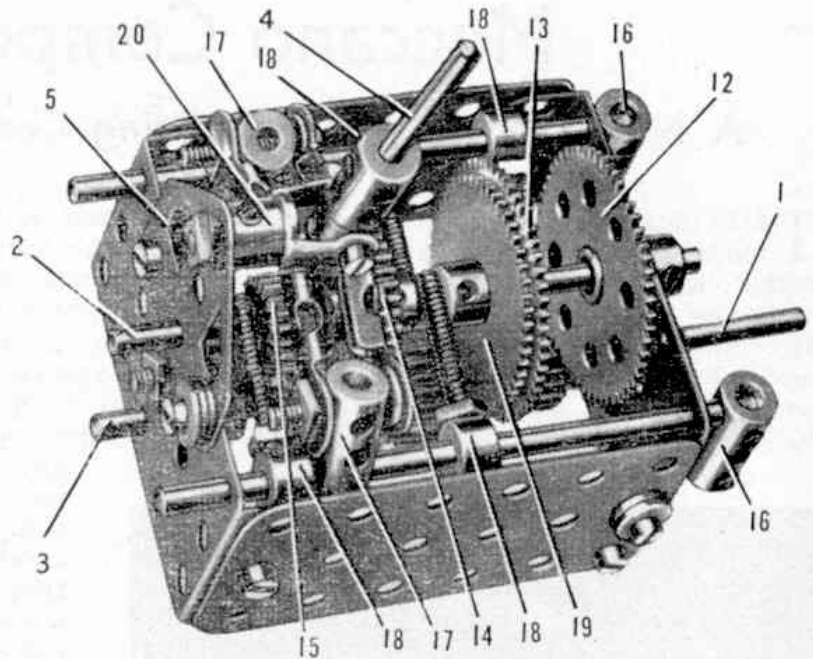

Fig. 1. A three-speed and reverse gear-box that makes use of the new Rod with Keyway, Part No. 230.

in a Double Bent Strip, and it carries a $\frac{1}{2}"$ Pinion 6. The end of the input shaft projects slightly into a $\frac{1}{2}"$ Pinion 7 on the output shaft 3. The output shaft carries also a $\frac{3}{4}"$ Pinion 8, a 1" Gear 9 and a $\frac{1}{2}"$ Pinion 10. A $\frac{1}{2}"$ reverse Pinion 11 is free to turn on a $\frac{3}{4}"$ Bolt that is attached to the housing by two nuts, and this Pinion is in constant mesh with Pinion 10.

The layshaft is a 4" Rod with Keyway 2, and it carries two 57-tooth Gears 12 and 13, a 50-tooth Gear 14 and a $\frac{1}{2}"$ Pinion 15. The Gear 12 is fixed on the shaft and is in constant mesh with Pinion 6, but the other gears are free to slide and are made to turn with the shaft by Key Bolts screwed into their bosses.

The selector shafts are $3\frac{1}{2}"$ Rods and each carries two Couplings 16 and 17 and two Collars 18. A 1" Rod in Coupling 16 is free to slide in a hole in one of the Flanged Plates and serves to prevent the selector shaft from turning. A 1" Screwed Rod is screwed into one of the holes in each of the Collars 18 and

is fixed in place by a nut. The two Screwed Rods on one side are arranged so that they form a fork with two prongs that engage one on either side of the Gears 13 and 19, and the two Screwed Rods at the opposite side are similarly

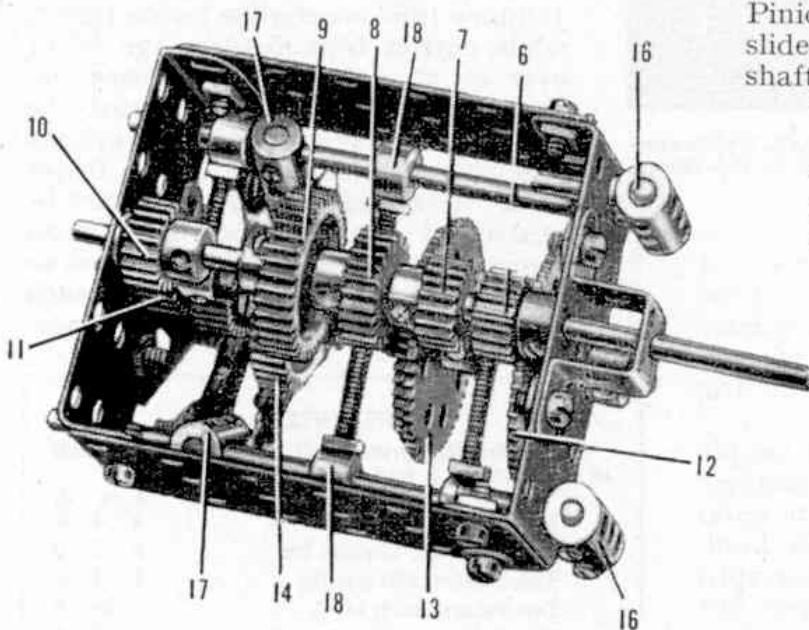

Fig. 2. The three-speed and reverse gear-box seen from underneath.

arranged to engage the Gear 14 and the Pinion 15.

The gear-change lever is a $1\frac{1}{2}$ " Rod 4 fitted in a Short Coupling that is fixed to a Centre Fork held in a Swivel Bearing 20. The Swivel Bearing is mounted on a $\frac{1}{2}$ " Bolt that is lock-nutted to the Flat Trunnion 5. The Centre Fork engages between pairs of Rod and Strip Connectors on each side, fixed by $\frac{3}{4}$ " Bolts in the Couplings 17.

Low or first gear is engaged by moving the lever 4 so that the Centre Fork engages the lower pair of Rod and Strip Connectors (Fig. 1), then by sliding these to the right the Gear 14 is moved into mesh with the Gear 9. Movement of the lever 4 in the opposite direction results in Pinion 15 engaging Pinion 11 to provide reverse gear.

Second and third gears are engaged by sliding the Centre Fork between the upper pair of Rod and Strip Connectors (Fig. 1).

Second gear is engaged by sliding Gear 19 into mesh with Pinion 8,

F. Pares Canalias, Madrid, proudly displays a fine model of a Massey-Harris Combine that he completed recently. This 11-year old boy is a keen Meccano enthusiast. We are indebted for our picture to Massey-Harris Ferguson (Sales) Ltd., Coventry.

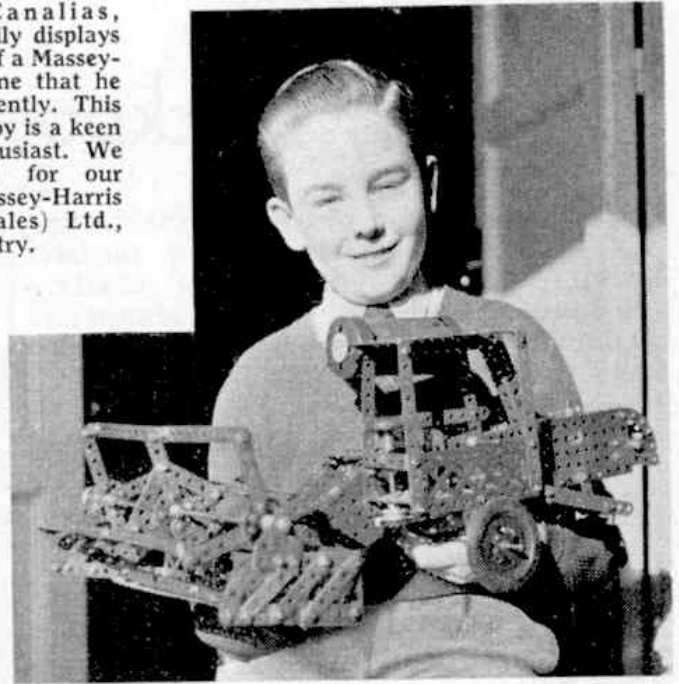

and top gear is provided when Gear 13 engages the Pinion 7.

Creepers Track for Large Models

One of the points that comes up time and time again in my correspondence concerns the assembly of creepers tracks for tractors, excavators, etc., and it is evident that many model-builders would like guidance on this subject.

The provision of tracks for small models presents no difficulty, as lengths of standard Sprocket Chain can be used with realistic effect, but a wider and heavier track is required for large models. I have previously illustrated one or two examples of suitable built-up creepers tracks. To help model-builders who missed the previous examples, however, this month I am including details of a creepers track arrangement devised by Lt. Col. J. G. M. Keeling, who used this method for making the tracks of a model excavator he entered in a Meccano competition.

The track plates used in this arrangement consist of a series of $2\frac{1}{2}$ " Flat Girders and made-up flat girders formed by $2\frac{1}{2}$ " Strips connected by Fishplates. To assemble the plates to form an endless track of the

(Continued on page 544)

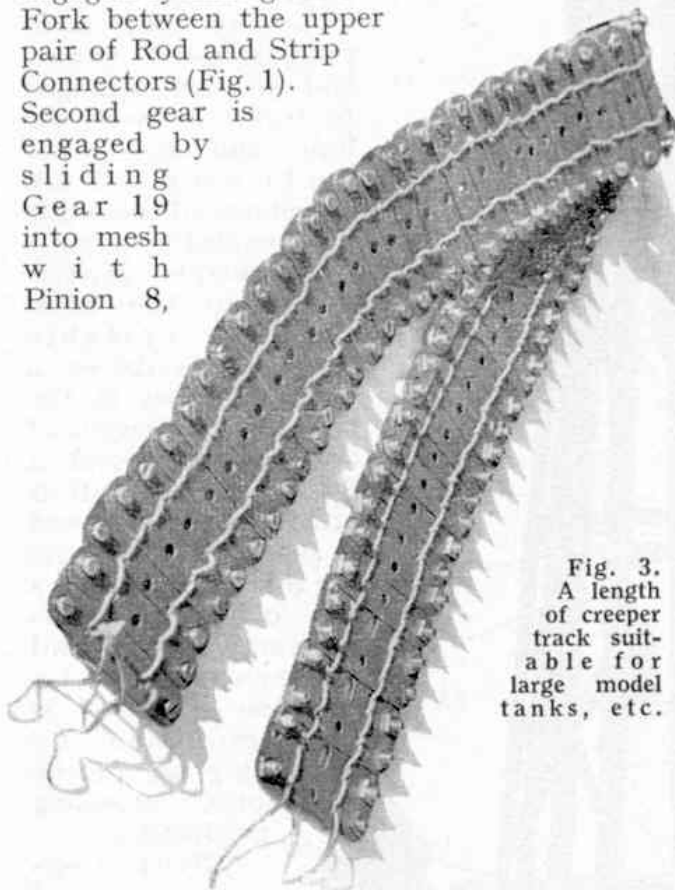

Fig. 3. A length of creepers track suitable for large model tanks, etc.

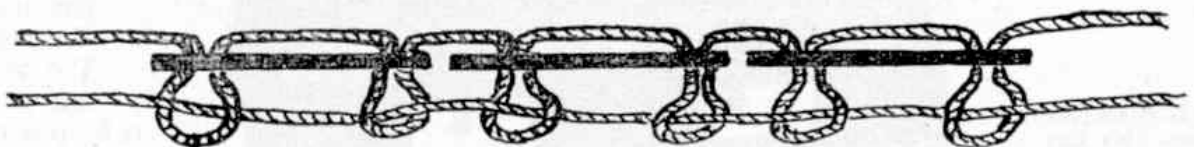

Fig. 4. A sketch showing the arrangement of the cords in building creepers track of the kind seen in Fig. 3.

arranged to engage the Gear 14 and the Pinion 15.

The gear-change lever is a $1\frac{1}{2}$ " Rod 4 fitted in a Short Coupling that is fixed to a Centre Fork held in a Swivel Bearing 20. The Swivel Bearing is mounted on a $\frac{1}{2}$ " Bolt that is lock-nutted to the Flat Trunnion 5. The Centre Fork engages between pairs of Rod and Strip Connectors on each side, fixed by $\frac{3}{4}$ " Bolts in the Couplings 17.

Low or first gear is engaged by moving the lever 4 so that the Centre Fork engages the lower pair of Rod and Strip Connectors (Fig. 1), then by sliding these to the right the Gear 14 is moved into mesh with the Gear 9. Movement of the lever 4 in the opposite direction results in Pinion 15 engaging Pinion 11 to provide reverse gear.

Second and third gears are engaged by sliding the Centre Fork between the upper pair of Rod and Strip Connectors (Fig. 1).

Second gear is engaged by sliding Gear 19 into mesh with Pinion 8,

F. Pares Canalias, Madrid, proudly displays a fine model of a Massey-Harris Combine that he completed recently. This 11-year old boy is a keen Meccano enthusiast. We are indebted for our picture to Massey-Harris Ferguson (Sales) Ltd., Coventry.

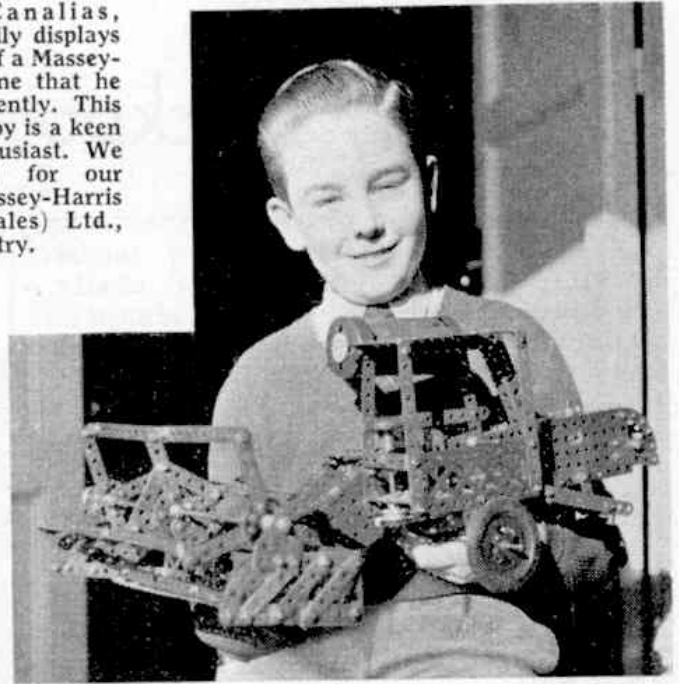

and top gear is provided when Gear 13 engages the Pinion 7.

Creepers Track for Large Models

One of the points that comes up time and time again in my correspondence concerns the assembly of creepers tracks for tractors, excavators, etc., and it is evident that many model-builders would like guidance on this subject.

The provision of tracks for small models presents no difficulty, as lengths of standard Sprocket Chain can be used with realistic effect, but a wider and heavier track is required for large models. I have previously illustrated one or two examples of suitable built-up creepers tracks. To help model-builders who missed the previous examples, however, this month I am including details of a creepers track arrangement devised by Lt. Col. J. G. M. Keeling, who used this method for making the tracks of a model excavator he entered in a Meccano competition.

The track plates used in this arrangement consist of a series of $2\frac{1}{2}$ " Flat Girders and made-up flat girders formed by $2\frac{1}{2}$ " Strips connected by Fishplates. To assemble the plates to form an endless track of the

(Continued on page 544)

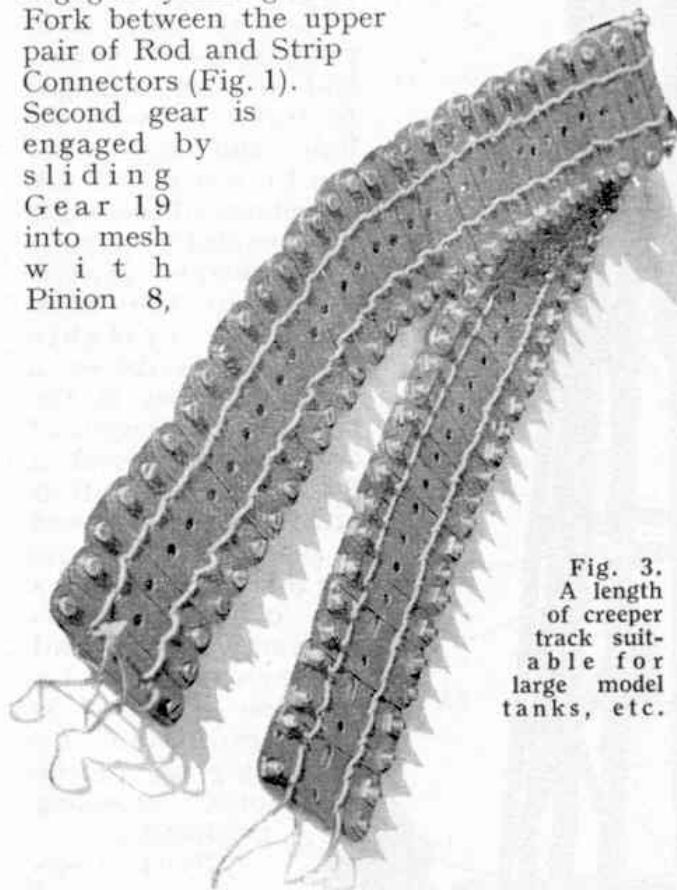

Fig. 3. A length of creepers track suitable for large model tanks, etc.

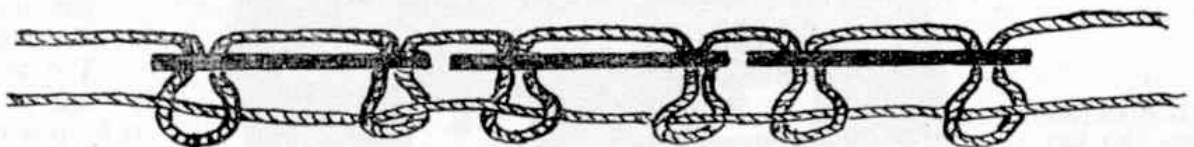

Fig. 4. A sketch showing the arrangement of the cords in building creepers track of the kind seen in Fig. 3.

arranged to engage the Gear 14 and the Pinion 15.

The gear-change lever is a $1\frac{1}{2}$ " Rod 4 fitted in a Short Coupling that is fixed to a Centre Fork held in a Swivel Bearing 20. The Swivel Bearing is mounted on a $\frac{1}{2}$ " Bolt that is lock-nutted to the Flat Trunnion 5. The Centre Fork engages between pairs of Rod and Strip Connectors on each side, fixed by $\frac{3}{4}$ " Bolts in the Couplings 17.

Low or first gear is engaged by moving the lever 4 so that the Centre Fork engages the lower pair of Rod and Strip Connectors (Fig. 1), then by sliding these to the right the Gear 14 is moved into mesh with the Gear 9. Movement of the lever 4 in the opposite direction results in Pinion 15 engaging Pinion 11 to provide reverse gear.

Second and third gears are engaged by sliding the Centre Fork between the upper pair of Rod and Strip Connectors (Fig. 1).

Second gear is engaged by sliding Gear 19 into mesh with Pinion 8,

F. Pares Canalias, Madrid, proudly displays a fine model of a Massey-Harris Combine that he completed recently. This 11-year old boy is a keen Meccano enthusiast. We are indebted for our picture to Massey-Harris Ferguson (Sales) Ltd., Coventry.

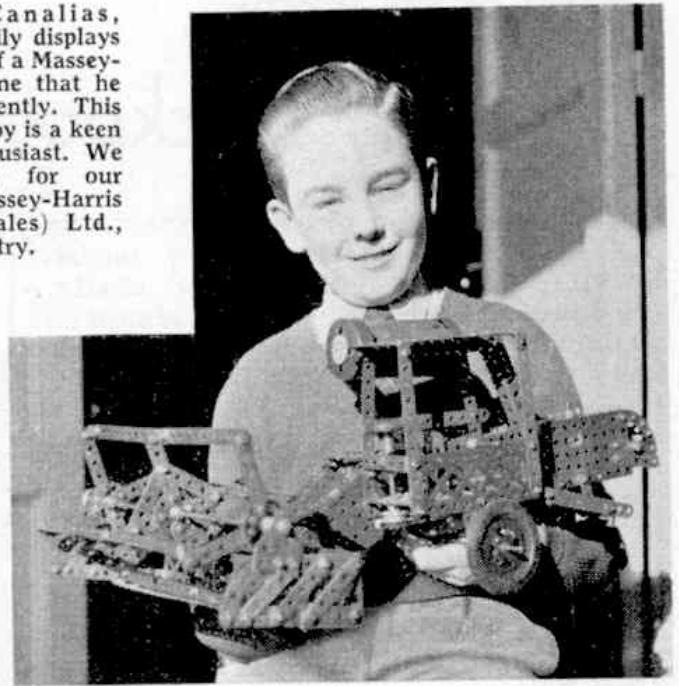

and top gear is provided when Gear 13 engages the Pinion 7.

Creepers Track for Large Models

One of the points that comes up time and time again in my correspondence concerns the assembly of creepers tracks for tractors, excavators, etc., and it is evident that many model-builders would like guidance on this subject.

The provision of tracks for small models presents no difficulty, as lengths of standard Sprocket Chain can be used with realistic effect, but a wider and heavier track is required for large models. I have previously illustrated one or two examples of suitable built-up creepers tracks. To help model-builders who missed the previous examples, however, this month I am including details of a creepers track arrangement devised by Lt. Col. J. G. M. Keeling, who used this method for making the tracks of a model excavator he entered in a Meccano competition.

The track plates used in this arrangement consist of a series of $2\frac{1}{2}$ " Flat Girders and made-up flat girders formed by $2\frac{1}{2}$ " Strips connected by Fishplates. To assemble the plates to form an endless track of the

(Continued on page 544)

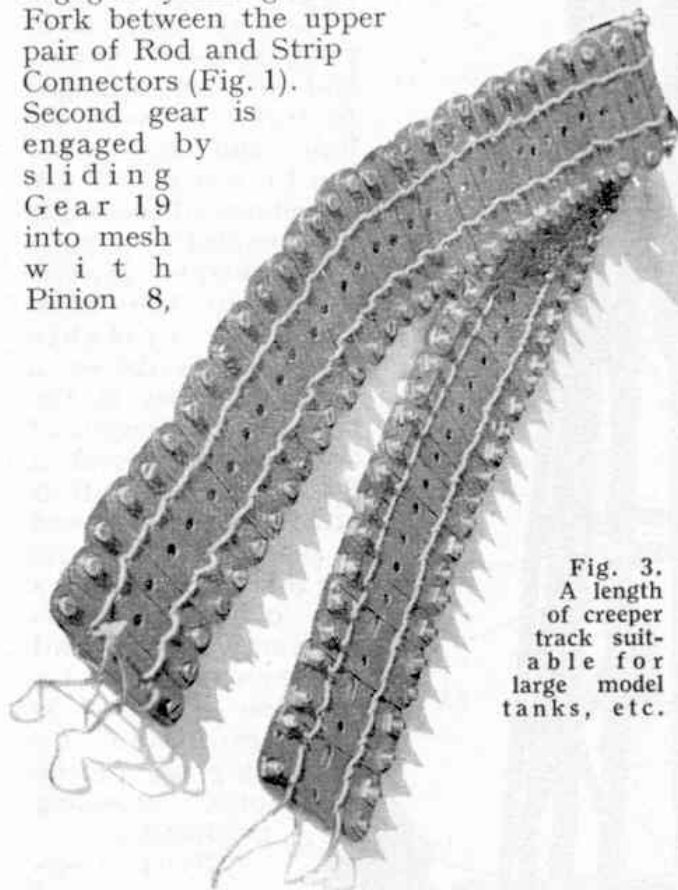

Fig. 3. A length of creepers track suitable for large model tanks, etc.

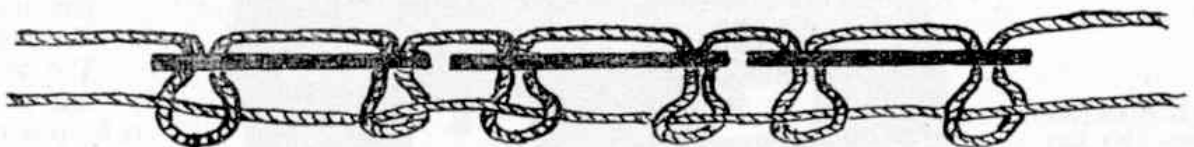

Fig. 4. A sketch showing the arrangement of the cords in building creepers track of the kind seen in Fig. 3.

Among the Model-Builders

By "Spanner"

Two-Speed Gear-Box

Mr. M. H. Fay, Guildford, is a keen model-builder with a fine collection of parts that he is continually enlarging. Among his possessions is an E20R Electric Motor, and on one occasion he used it as the power unit in a model vehicle. Mr. Fay also has a No. 1 Clockwork Motor, and he made use of the final drive pinion from this in the construction of an interesting gear-box he designed for the vehicle. The gear-box provides two forward speeds, and its special claim to mention lies in the fact that its overall depth is only a little greater than the width of a Strip or an Angle Girder. This makes it particularly suitable for use in models such as underfloor engined buses and coaches, since it enables a flat floor to be built over the mechanism without leaving a large gap between the floor and the chassis.

The gear-box is shown in Fig. 1 and it will be seen that the housing is formed by two $5\frac{1}{2}$ " Strips joined by three $2\frac{1}{2}$ " \times $\frac{1}{4}$ " Double Angle Strips. In an actual model however, the Double Angle Strips can be bolted between the Strips or the Girders that form the chassis of the vehicle.

The input shaft to the gear-box is mounted in one of the Double Angle Strips and it carries a Bush Wheel 1 fitted with two Threaded Pins that engage holes in a Bush Wheel 2. This Bush Wheel is fixed on a Rod that is able to slide about $\frac{1}{4}$ " in holes in two of the Double Angle Strips, and which carries a $\frac{1}{2}$ " Pinion 3, a Coupling 4 and the Clockwork Motor pinion 5. Coupling 4 is mounted loosely on the Rod

between the Pinions 3 and 5, and it is fixed on a Rod 6 that also is mounted in two of the Double Angle Strips. This Rod serves to hold the Coupling in a horizontal position, and a $1\frac{1}{4}$ " Bolt fixed by a nut in the Coupling forms a gear change lever.

The output shaft 7 carries a $\frac{1}{2}$ " Pinion 8 and a $\frac{1}{4}$ " Pinion 9. When the slideable Rod is

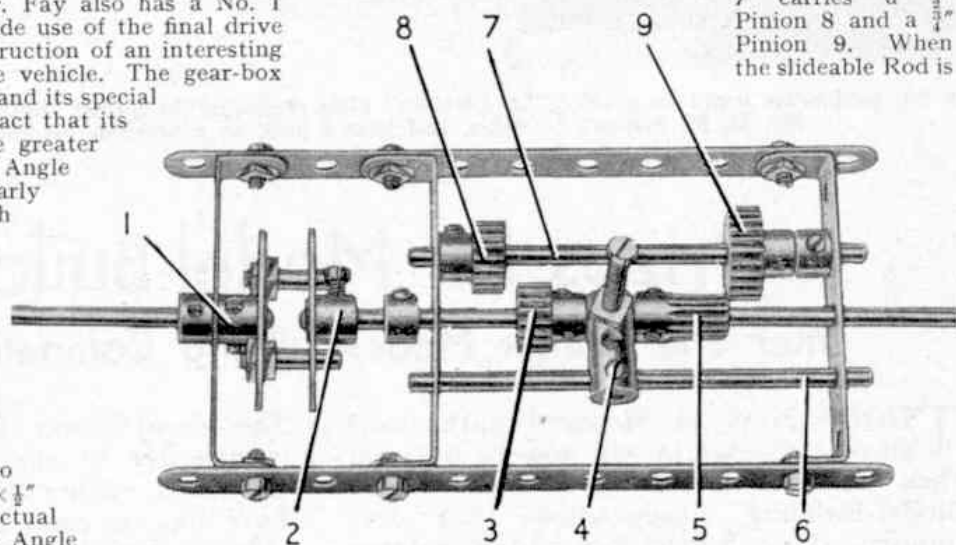

Fig. 1. A suggestion for a two-speed gear-box sent in by M. H. Fay, Guildford. It is described in detail on this page.

moved to the left, Fig. 1, pinions 3 and 8 engage and provide top gear. When the Rod is moved to the right these Pinions disengage and pinion 5 is brought into mesh with Pinion 9.

What is it?

The arrival of a baby boy in the family of Mr. K. Birkett, Cheadle Hulme, who was a keen Meccano fan in his youth, appeared to be the perfect excuse for him to resume his active interest in the hobby. He realised of course that he would have to wait a few years before he could introduce his son to the hobby, but time soon passed, and when the boy reached the age of six years, he was duly presented by Father Christmas with a Meccano Outfit No. 3. He quickly picked up the model-building idea, and after a little instruction in the matter of tightening up the nuts and bolts it was not very long before he was able to put the various pieces together.

On one occasion the boy was left alone for an hour or so with the Outfit, while his father attended to some other important business. When he eventually returned to the room Mr. Birkett was surprised to see on the table a curious Meccano construction that in his own words, "defied description." On enquiring what this was supposed to be, his son told him that it was "something out of his head," with which his father had to be content.

This curious structure is shown in the upper illustration on the next page, and it appeared to give the child more enjoyment than anything he had built from the



The young son of Mr. Parks, Peacehaven, photographed with a model bus built by his father, that was displayed in a local Meccano dealer's shop window.

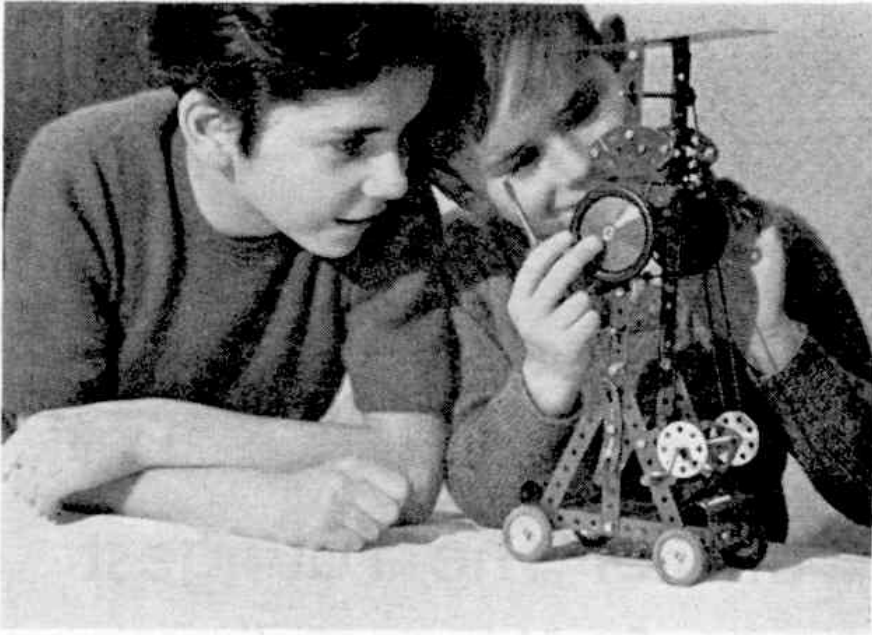

Jean Birkett watches her brother Ronald, aged six, putting the finishing touches to an entirely original model. See the story on these pages.

Instructions Book! His sister also appeared to be able to see something in her brother's weird and wonderful production, but Mr. Birkett says that it escaped him completely.

This is not the only "model" Ronald has produced by this method, but his father says that he is looking forward to the time when he will find something on the table that he can recognise!

Intermittent Ratchet Feed Mechanism

Following the recent introduction of the 4" Rod with Keyway and the Key Bolt, many model-builders have written to say how pleased they are with these new parts, and how useful they have found them, either in building new mechanisms or making novel variations of older and more orthodox mechanisms. Some ingenious mechanisms and devices made possible by the introduction of the new parts have been brought to my notice, and in most of these the Rod with Keyway and the Key Bolts are used to enable Gears and Pinions to turn with the Rod while they are free to slide along it. Of course this use of the new parts is the primary reason why they were added to the range, but several other uses can be found for them and one example of these is shown in Fig. 2.

The mechanism illustrated is designed to provide an intermittent ratchet feed to two shafts from a common input shaft that is driven continuously. A Rod with Keyway is used to support the Pawls of the ratchet mechanisms, and Key Bolts engaging the slot in the Rod ensure that although the Rod is free to slide it cannot rotate in its bearings. While it is possible to provide this arrangement in other ways the construction is simplified considerably by the use of the new parts.

The driving shaft carries a Bush Wheel 1 fitted with a Threaded Pin, and a 5½" Slotted Strip 2 is passed over the Pin as shown and is held in place by a Collar. The Slotted Strip pivots freely on a ¾" Bolt fixed by two nuts in a Double Bent Strip. A second ¾" Bolt is passed through the Slotted Strip and is screwed into a Coupling 3, which is fixed on a 4" Rod with Keyway 4. The Rod with Keyway is free to slide in two Short Couplings 5, and a further Short Coupling 6 is fixed at each of its ends. A Pawl without boss is pivoted freely on a bolt fixed in each of the Short Couplings 6 by a nut. The Pawl engages the teeth of a Ratchet Wheel fixed on the output shaft.

The Rod with Keyway is prevented from turning by Key Bolts screwed into the Short Couplings 5 so that their spigots engage the slot in the Rod.

SUGGESTIONS PLEASE!

At this time of the year many boys join the ranks of Meccano model-builders for the first time. Although the System is so delightfully simple that any boy who can use a Spanner and a Screwdriver can start building right away, inevitably problems will crop up from time to time. On the other hand, experienced model-builders and newcomers to the hobby alike often come across a novel design or mechanism, or think of a new part they consider would make a valuable addition to the range. Whether you have a problem or an idea, write and let me have details of it. I shall be delighted to help you with your difficulties and I will consider any new suggestions you have to put forward. Ideas for new parts are always interesting, but you should bear in mind that we must avoid introducing parts which while of great value to some model-builders, are of little use to the majority of boys who are interested in the popular kinds of models. However, if you have any ideas or problems on your mind, don't hesitate to write to me.

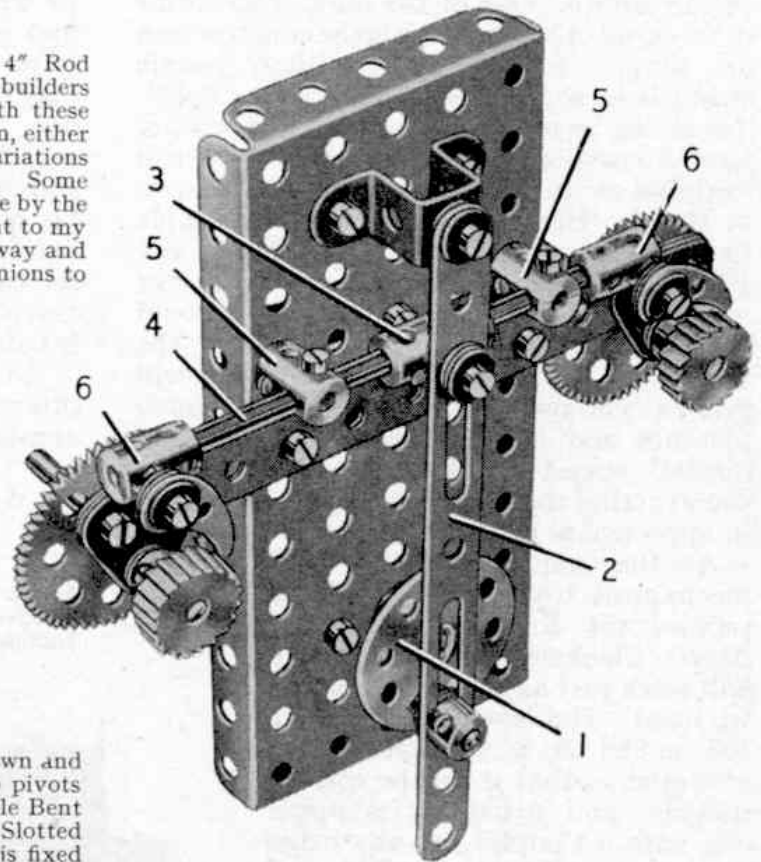
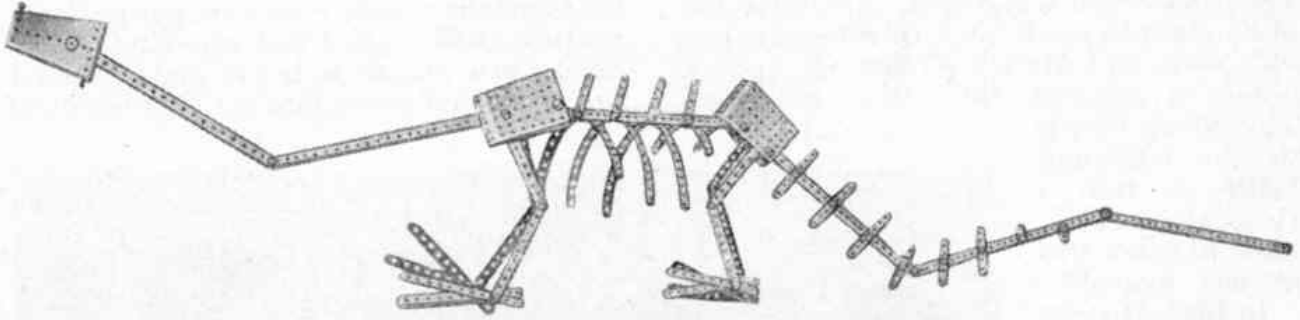

Fig. 2. Experienced model-builders will be able to find several uses for an intermittent ratchet feed mechanism of the kind shown in this illustration. Details are given on this page.



It went—and "Doynged" as Well!

By R. V. Dickson

WITH *Punch*, *Picture Post*, the local daily, etc., there lay a small magazine with a fine picture in colour on the cover, and I, a portly forty, found long forgotten joy in its perusal, mixed with curiosity. It was the *M.M.* This could have been none of my wife's shopping, I thought. She reported: "Bessie bought it." And any passing doubts of the sanity of my hard-headed, business-woman elder sister Bessie vanished when I learned that she saw it on a bookstall, and bought it "because she remembered I used to take it."

After my digestion of every line, the Magazine passed on to a client's child isolated from his Meccano by a prolonged stay in hospital with a grim complaint, and for three years since I have seen to it that the supply is maintained.

The humble 1/- that brings to Master X his current Meccano news, brings also to me a host of memories. Sets were once numbered 0 to 7, and I was a Craftsman, apprenticed on a No. 1. Then came nervous illness, spread over the ages seven to ten, with long confinements to bed. My complaint was relieved and, I am quite prepared to argue, largely vanquished, by frequent contributions of ever more parts and pieces. There were Gears, Pinions, Worms, Plates, Rods, Crankshafts, Girders, Strips, Wheels Flat and Wheels Flanged, Wheels large and Wheels small, Wheels, Pulley and Trunnions, Flat. How dear mother puzzled over that last request—"What on earth is a Trunnion?" she asked. Pawls and Ratchets, Sprockets and Eccentrics—this should be set to music!—all were enlisted in the swelling ranks of my beloved army. And when motors gave life to the cold steel, joy was unconfined! Those were the days!

Can you recall your first Meccano model? I can. Two 12½"

Strips similarly joined at ends by 2½" Angle Girders, 3½" Rods through the third hole from each end, four 1" Pulleys for wheels, two more 12½" Strips similarly joined at one end only, the free ends bolted, not too tightly, into the second holes from one end, string to simulate the steps of a ladder—and behold, a Fire Engine! Not from the book. Straight from the brain. I was seven!

I made a "Tank" that was really nothing more than a Clockwork Motor fitted with Sprocket Wheels and Chains, an outrageous Well Wagon and a Petrol Bowser, with a Cerebos Salt tin for a tank, a vast furniture van, and a suicidal Big Dipper, and from the manual, "The Wrestlers" and the Diplodocus, who is most dejected when he droops, as you can see from his picture.

And then came the Thing. It began, I think, as a stationary steam engine. A

(Continued on page 652)

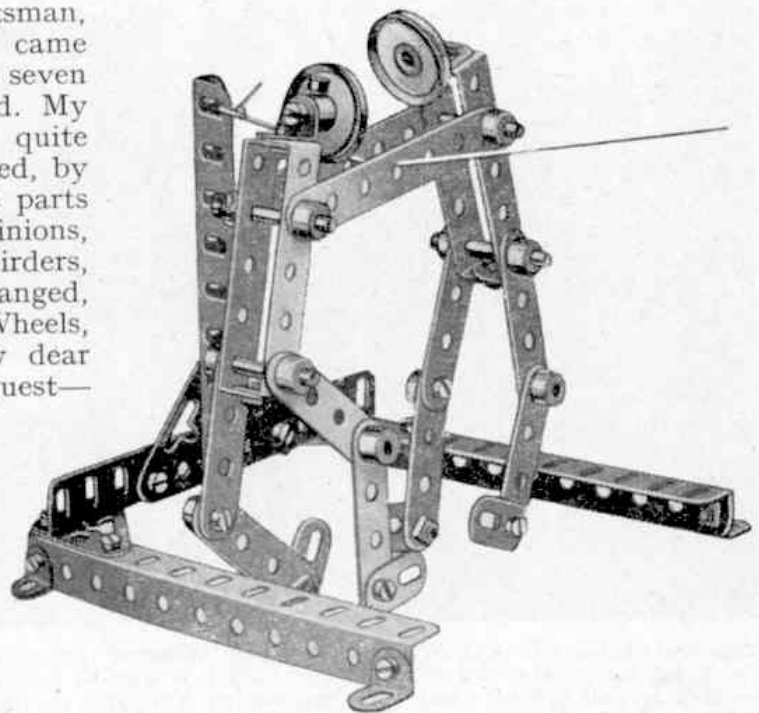

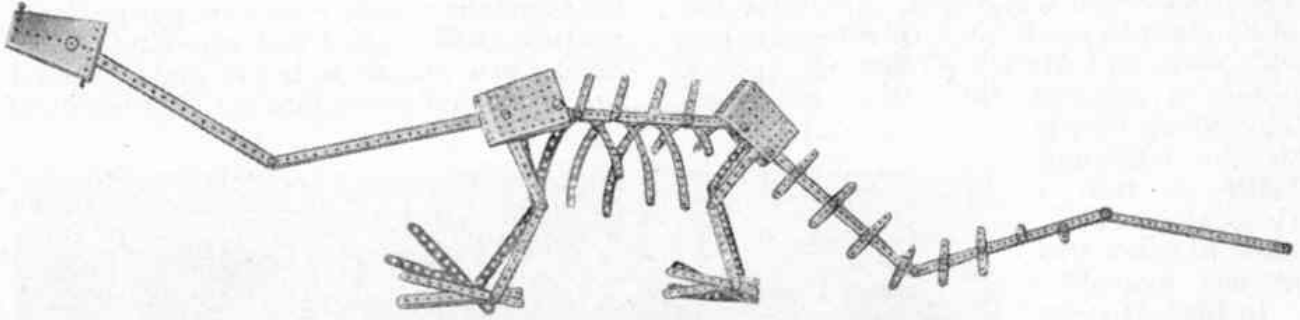

It went—and "Doynged" as Well!

By R. V. Dickson

WITH *Punch*, *Picture Post*, the local daily, etc., there lay a small magazine with a fine picture in colour on the cover, and I, a portly forty, found long forgotten joy in its perusal, mixed with curiosity. It was the *M.M.* This could have been none of my wife's shopping, I thought. She reported: "Bessie bought it." And any passing doubts of the sanity of my hard-headed, business-woman elder sister Bessie vanished when I learned that she saw it on a bookstall, and bought it "because she remembered I used to take it."

After my digestion of every line, the Magazine passed on to a client's child isolated from his Meccano by a prolonged stay in hospital with a grim complaint, and for three years since I have seen to it that the supply is maintained.

The humble 1/- that brings to Master X his current Meccano news, brings also to me a host of memories. Sets were once numbered 0 to 7, and I was a Craftsman, apprenticed on a No. 1. Then came nervous illness, spread over the ages seven to ten, with long confinements to bed. My complaint was relieved and, I am quite prepared to argue, largely vanquished, by frequent contributions of ever more parts and pieces. There were Gears, Pinions, Worms, Plates, Rods, Crankshafts, Girders, Strips, Wheels Flat and Wheels Flanged, Wheels large and Wheels small, Wheels, Pulley and Trunnions, Flat. How dear mother puzzled over that last request—"What on earth is a Trunnion?" she asked. Pawls and Ratchets, Sprockets and Eccentrics—this should be set to music!—all were enlisted in the swelling ranks of my beloved army. And when motors gave life to the cold steel, joy was unconfined! Those were the days!

Can you recall your first Meccano model? I can. Two 12½"

Strips similarly joined at ends by 2½" Angle Girders, 3½" Rods through the third hole from each end, four 1" Pulleys for wheels, two more 12½" Strips similarly joined at one end only, the free ends bolted, not too tightly, into the second holes from one end, string to simulate the steps of a ladder—and behold, a Fire Engine! Not from the book. Straight from the brain. I was seven!

I made a "Tank" that was really nothing more than a Clockwork Motor fitted with Sprocket Wheels and Chains, an outrageous Well Wagon and a Petrol Bowser, with a Cerebos Salt tin for a tank, a vast furniture van, and a suicidal Big Dipper, and from the manual, "The Wrestlers" and the Diplodocus, who is most dejected when he droops, as you can see from his picture.

And then came the Thing. It began, I think, as a stationary steam engine. A

(Continued on page 652)

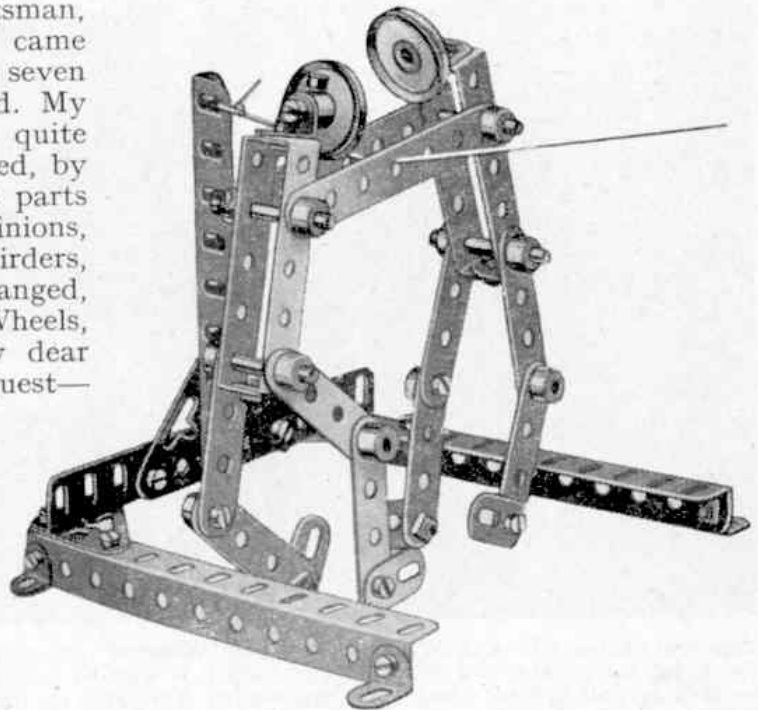

Among the Model-Builders

By "Spanner"

A SIMPLE THREE-SPEED AND REVERSE GEAR-BOX

I am utilising most of my space this month to describe a simple three-speed and reverse gear-box, which is shown on this page. I am doing so in order

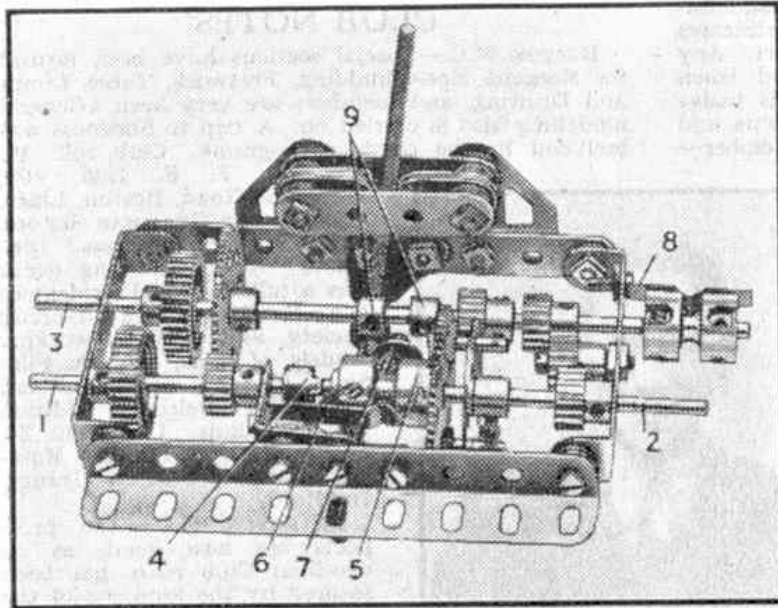

A simple three-speed and reverse gear-box with gate change, suitable for a car chassis.

to satisfy the demands of several model-builders who have written to me recently asking for help on this subject. The gear-box shown is simple and is a suitable type for incorporation in a motor car chassis.

The driving shaft 1 carries a 1" Gear against the Double Angle Strip, and a $\frac{1}{2}$ " Pinion that bears against the Angle Bracket, and on the other side of the Angle Bracket one member of a Dog Clutch 4. The Rod does not occupy the full extent of the bore of the Dog Clutch member, as this serves also as a bearing for the end of the driven Rod 2.

The Rod 2 is fitted with a $\frac{1}{2}$ " Pinion, the boss of which bears against the Double Angle Strip at the end of the gear-box and so prevents the inner end of the Rod from slipping out of the Dog Clutch. The Pinion is in constant mesh with another Pinion rotating freely on a $\frac{1}{2}$ " Bolt fixed as shown. A Socket Coupling 5 on the Rod 2 carries the second member of the Dog Clutch to engage with the member 4, and a 57-teeth Gear. Two Threaded Pins are attached to the Gear and engage opposite holes in a Bush Wheel fixed on the Rod. The Socket Coupling unit is able to slide on the Rod, but is prevented from rotating by the Bush Wheel and Threaded Pins.

The layshaft 3 is a slideable $6\frac{1}{2}$ " Axle Rod and carries a 1" Gear, a 57-teeth Gear, two Collars 9, two $\frac{1}{2}$ " Pinions and a Socket Coupling.

To each side Angle Girder of the frame is bolted a 1" Corner Bracket, and these support a $3\frac{1}{2}$ " Rod mounted transversely beneath the gear-box. The Rod carries a Double Arm Crank and a Collar. A $3\frac{1}{2}$ " Screwed Rod is inserted in one of the tapped bores of the Collar and is locked securely by a nut, the Collar being fixed to its Rod by the Grub Screw. A $\frac{3}{8}$ " Bolt 7 is attached to the Double Arm Crank by means of two nuts, and forms the selector for changing gear. The head of the bolt can be made to engage between the Collars 9, or the shank can be engaged in the groove of the Socket Coupling 5.

Construction of the gate for the gear lever will be clear from the illustration.

In the illustration the gear-box is shown with the gear-changing lever in the neutral position. Sliding movement of the layshaft and the Socket Coupling is checked by two Pendulum Connections 6 and 8, which are bent as shown to engage the grooves in the Socket Coupling. When the gear lever is in the neutral position, the $\frac{3}{8}$ " Bolt 7 should be in line with the groove of the Socket Coupling 5, and the space between the two Collars 9. By sliding the lever to one or other side of the gate the $\frac{3}{8}$ " Bolt is made to engage either the Socket Coupling or the Collars, and thus the gears can be selected.

First forward speed is obtained when the Bolt 7 engages the Socket Coupling 5, and the lever is moved backward, that is to the right of the illustration.

In this position the Socket Coupling is moved against the action of the spring 6, until the 57-teeth Gear engages one of the $\frac{1}{2}$ " Pinions on the layshaft. The drive is then taken through the $\frac{1}{2}$ " Pinion on the driving shaft to the 57-teeth Gear on the layshaft, and through a $\frac{1}{2}$ " Pinion and 57-teeth Gear to the Bush Wheel fixed on the Rod 2. The drive is led through two stages of 3:1 reduction gearing, giving a total reduction ratio of 9:1.

The second forward speed is got by moving the lever back to the neutral position, sliding it through the gate so that the Bolt 7 engages the Collars 9, and then moving it forward. In this position the 1" Gear on the layshaft is brought into mesh with the similar Gear on the driving shaft, and also one of the $\frac{1}{2}$ " Pinions on the layshaft meshes with the 57-teeth Gear of the Socket Coupling unit. In this way the drive is taken through a 1:1 ratio and a 3:1 ratio, the total reduction being 3:1.

To obtain top gear the lever is moved back to neutral, through the gate, and then pushed forward so that the Dog Clutch member in the Socket Coupling 5 engages the member 4. The drive is then taken direct from the Rod 1 to the Rod 2, the Socket Coupling being "keyed" to the latter by the Threaded Pins and Bush Wheel.

To engage reverse gear the gear lever is moved back again to neutral and once more the bolt 7 engages the Collars 9. In this case the layshaft is slid to the right.

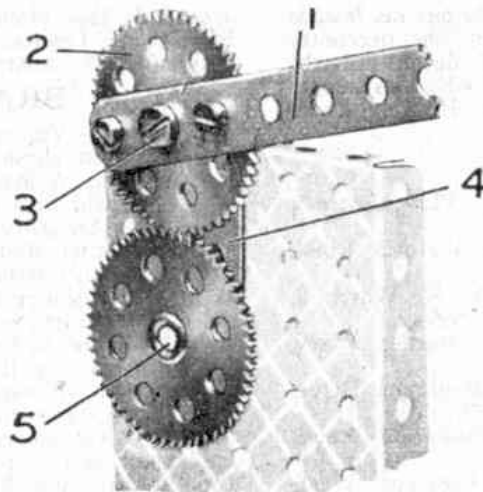

Sun and planet mechanism.

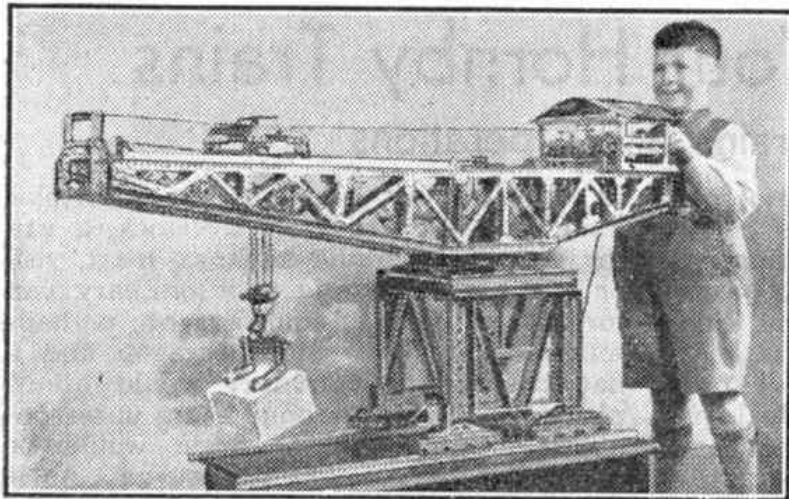

A fine example of a Meccano super model block-setting crane, photographed with its builder, John Ryall, Grimsby.

A CHANGE FROM THE CRANK

Builders of beam and other types of steam engines will find it an interesting change to use a "sun and planet" mechanism instead of the customary crank for converting the reciprocating motion of the piston into rotary motion. A simple sun and planet gear is shown at the foot of the facing page. The Strip 1 represents the engine connecting rod, imparting reciprocating motion from the piston. This Strip is bolted to a 57-teeth Gear 2, which is free to move about a Pivot Bolt 3 fixed to a 2" Strip 4. The Strip 1 should be spaced away from the Gear 5 by three Washers.

The Gear 2 does not revolve on its own centre but moves round the axis of the Gear 5, with a slightly oscillating motion; and since the teeth of both Gears are in engagement, a rotary movement is imparted to the Gear 5. The latter revolves twice on its axis to one circuit of Gear 2.

AN IDEA FOR BUILDERS OF MACHINE TOOLS

A suggestion sent by V. Welsby, Cardiff, should interest A. Robins, Shrewsbury, and several other boys who have asked for details of quick-return devices suitable for use in machine tools such as planing and slotting machines. Welsby's idea is shown on this page. The movement is very efficient because the only sliding part is a reciprocating Eye Piece. The driving Crank 1 is pivotally attached to a 3½" Strip secured at 2 to a further 3½" Strip and

a 3" Strip, the last being bolted to a Crank that is free to swing about a fixed pivot 4, which consists of a Pivot Bolt. The second 3½" Strip is connected to the section of the model requiring a quick-return motion, and in the photograph is shown pivoted at 3 to a sliding Eye Piece. In a model planing machine the Eye Piece would be replaced by the work table.

In the position shown, The Crank 1, rotating anti-clockwise, is on the power stroke and thus the Eye Piece slides slowly to the left. When the web of the Crank swings towards the pivot 4 the Eye Piece returns rapidly.

A READER'S SUGGESTION

H. A. Sharp, Uckfield, suggests the introduction of a new Meccano part similar to the present Boiler End (Part No. 162a) but 3" diameter. He says that a part of this type and size would make an excellent road wheel for a vehicle if fitted with a 3" Motor Tyre (Part No. 142b). Such a wheel

could be fitted with a brake drum consisting of the present Boiler End, with a Face Plate for the back plate of the device.

The idea is interesting, especially if other uses could be found for the suggested new part. I shall be glad to have model-builders' opinions on the point.

CONTRIBUTIONS—A REMINDER

May I remind readers that I am always glad to receive contributions for "Among the Model-Builders." Payment at the usual rates will be made for material, photographs or sketches that I am able to use.

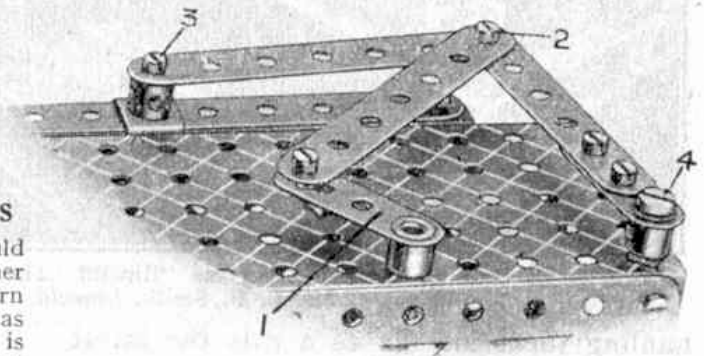

A quick-return motion that has many uses in Meccano model-building.

"Most Useful Meccano Parts" Competition

In the accompanying panel is a list of 10 Meccano parts. Readers are asked (1) to select from these the part that they think is the most useful in model-building, and (2) to make out a list of the six parts that they think will receive the most votes, placing these in their estimated order of popularity.

Entries should be sent on postcards, which must bear the competitor's name and address. The name or catalogue number of each part must be given and entries should be addressed "Most Useful Parts Contest," Meccano Ltd., Binns Road, Liverpool 13. The closing date for Home entries is 30th November and for

Overseas entries 31st January, 1946.

Prizes will be awarded to competitors in each section whose lists are nearest to the final result, and will be as follows. First, £2/2/-; Second £1/1/-; Third, 10/6. A number of consolation prizes also will be awarded.

If several competitors place the six most-useful parts in the correct order as decided by the votes of all competitors, the neatness of their entries will be taken into consideration in making the awards. No competitor may submit more than one entry.

All prizewinners will be notified by letter.

SELECT YOUR PARTS FROM THIS LIST

Part No.	Part No.
24 Bush Wheel	133 Corner Bracket
50a Eye Piece	137 Wheel Flange
59 Collar	161 Girder Bracket
63 Coupling	166 End Bearing
109 Face Plate	179 Rod Socket