

# A NEW MECCANO MODEL

Model No. 629

## RADIAL TRAVELLING CRANE

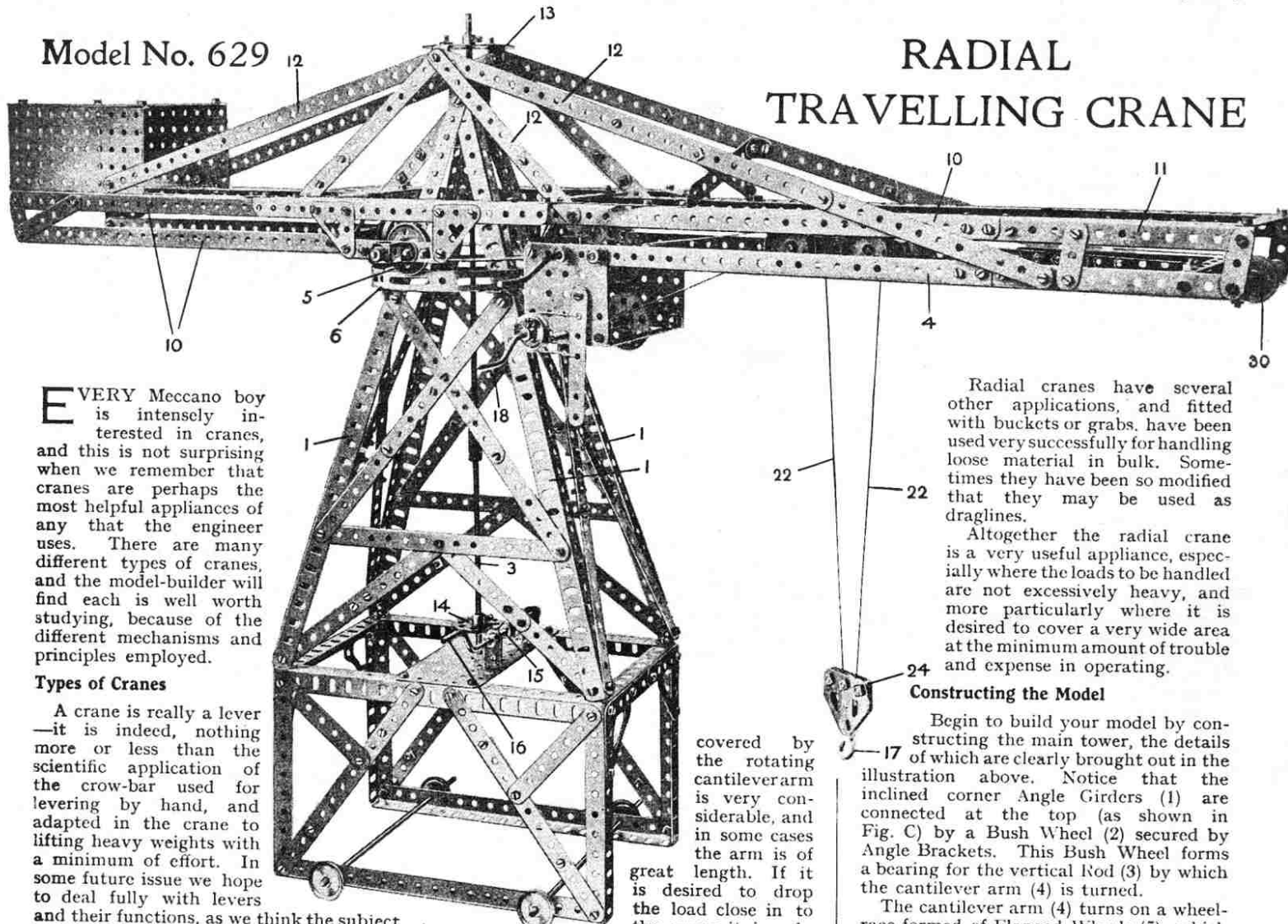

EVERY Meccano boy is intensely interested in cranes, and this is not surprising when we remember that cranes are perhaps the most helpful appliances of any that the engineer uses. There are many different types of cranes, and the model-builder will find each is well worth studying, because of the different mechanisms and principles employed.

### Types of Cranes

A crane is really a lever—it is indeed, nothing more or less than the scientific application of the crow-bar used for levering by hand, and adapted in the crane to lifting heavy weights with a minimum of effort. In some future issue we hope to deal fully with levers and their functions, as we think the subject will be of general interest to our readers.

Different requirements necessitate special cranes, each designed so as to be most serviceable under the special conditions imposed. There is, for instance, the comparatively small dock-side crane that runs astride the wharf and does not require a great deal of leg-room. Where space is not so important the base of the crane can be designed differently, which is fortunate, for a large base is necessary to give stability in the case of the hammer-head cranes used in our ship-building yards. These giant cranes lift boilers or big guns into position with the greatest ease.

### Radial Travelling Cranes

Our new model, which we here illustrate and describe, is a Radial Travelling Crane of the cantilever type. This type of crane is used on the Panama Railways at the docks for handling freight. They stand well back from the quay-side, lift their load from the hold of the ship and then swing round and dump the load on the ground behind the docks.

Radial cranes are also used extensively in iron and steel yards and in timber yards, where it is necessary to drop loads over a large area. The ground

covered by the rotating cantilever arm is very considerable, and in some cases the arm is of great length. If it is desired to drop the load close in to the crane it is only

necessary to run the travelling bogie inwards along the arm. This enables the load to be dropped at any point between the base of the crane and the end of the arm, and anywhere within the circle through which the arm may be moved.

### Other Applications

A modified form of the radial crane is used in ship-building, and mounted on steel trestles alongside the vessel that is being built. In these cases the cranes move on wheels which run on a track laid on the steel trestles.

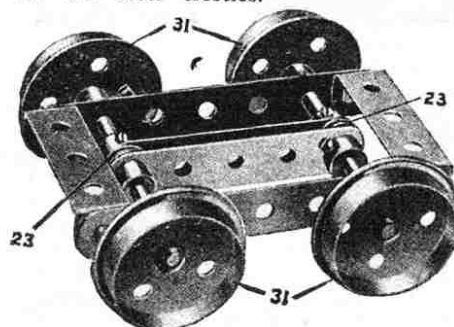

Fig. A. Trolley

Radial cranes have several other applications, and fitted with buckets or grabs, have been used very successfully for handling loose material in bulk. Sometimes they have been so modified that they may be used as draglines.

Altogether the radial crane is a very useful appliance, especially where the loads to be handled are not excessively heavy, and more particularly where it is desired to cover a very wide area at the minimum amount of trouble and expense in operating.

### Constructing the Model

Begin to build your model by constructing the main tower, the details of which are clearly brought out in the illustration above. Notice that the inclined corner Angle Girders (1) are connected at the top (as shown in Fig. C) by a Bush Wheel (2) secured by Angle Brackets. This Bush Wheel forms a bearing for the vertical Rod (3) by which the cantilever arm (4) is turned.

The cantilever arm (4) turns on a wheel-race formed of Flanged Wheels (5), which run on a Circular Girder\* (6) supported by four  $1\frac{1}{2} \times \frac{1}{2}$  Angle Brackets (7) bolted to the corner Girders (1). The cantilever is built up (as shown in Fig. B) from two  $9\frac{1}{2}$  Angle Girders (8) braced by two  $5\frac{1}{2}$  Angle Girders (9) overlapped nine holes. From these,  $12\frac{1}{2}$  Angle Girders (10) extend at one side, and to similar Girders (11) at the other side are connected  $5\frac{1}{2}$  Girders (11).

### Rotating the Arm

The inclined Strips (12) are connected at the top, by means of Angle Brackets, to a Face Plate (13) secured to the vertical Rod (3). At the foot of the Rod (3) is a  $1\frac{1}{2}$  Gear Wheel (14) engaged by a Worm Wheel (15) operated by the Crank Handle (16) and in this way the cantilever arm is swung round, the wheels (5) riding on the Circular Girder (6).

The load carried from the Hook (17) is raised or lowered by the Crank Handle (18), a  $\frac{1}{2}$  Pinion (19) on which engages a  $1\frac{1}{2}$  Gear Wheel (20) on a Rod (21) on which is wound a Cord (22). This Cord passes over a  $\frac{1}{2}$  Pulley (23) to the block (24) and back over another  $\frac{1}{2}$  Pulley on the trolley, and is secured to the  $3\frac{1}{2} \times \frac{1}{2}$  Double Angle Strip (25) at the outer end of the cantilever arm.

\* The Circular Girder, No. 143, is a new part, which is announced on page 195.

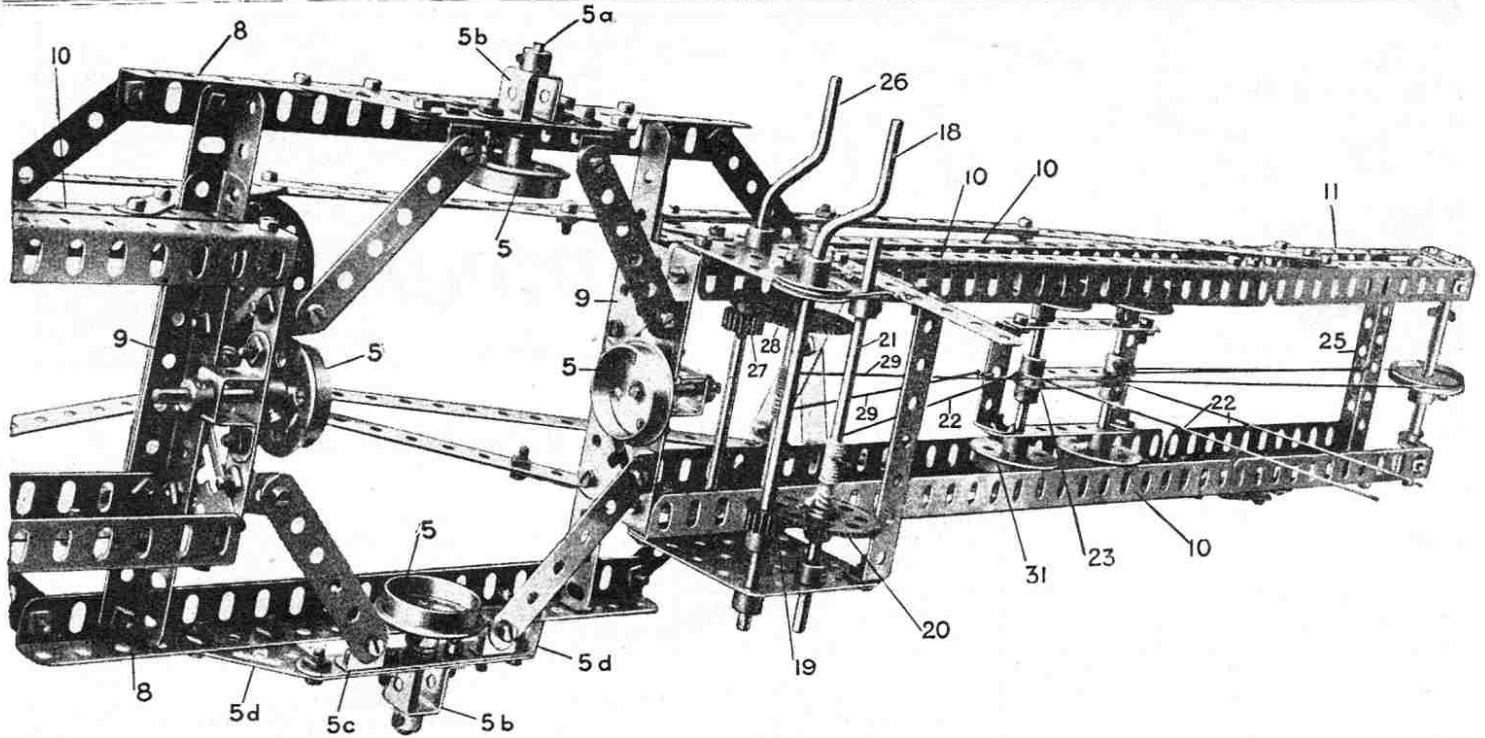

Fig. B. Details of the Cantilever Arm

Consequently, when the trolley is caused to travel along the cantilever arm the load remains suspended at a constant height—an important point and an interesting detail.

**The Movement of the Trolley**

The trolley is caused to move to and fro along the cantilever arm by the action of the Crank Handle (26). On this a  $\frac{1}{2}$ " Pinion (27) engages a  $1\frac{1}{2}$ " Gear Wheel (28) on a rod on which is wound the Cord (29), the opposite ends of which are connected to the opposite ends of the trolley. The Cord (29) passes round a Pulley (30) at the outer end of the jib. By turning the Crank Handle (26), therefore, the Cord (29) winds on and off its rod, and moves the trolley to and fro, its Wheels (31), as shown in Fig. A, running on the Angle Girders (10).

The Wheels (5) are connected to  $1\frac{1}{2}$ " Rods (5a) which are journalled in Double Bent Strips (5b) bolted to  $3\frac{1}{2}$ " Strips (5c) carried from the Angle Girders (8) by Corner Brackets (5d).

Parts required:—

6 of No. 1	1 of No. 24
2 " " 1b	2 " " 26
28 " " 2a	3 " " 27a
23 " " 3	1 " " 32
18 " " 4	2 " " 35
2 " " 5	292 " " 37
8 " " 6	61 " " 37a
6 " " 6a	10 " " 38
12 " " 7	1 " " 40
6 " " 8a	4 " " 45
18 " " 9	1 " " 46
22 " " 12	2 " " 48
4 " " 12b	4 " " 48b
1 " " 13	2 " " 52
2 " " 13a	1 " " 52a
1 " " 14	1 " " 53a
1 " " 15	1 " " 57
1 " " 15a	19 " " 59
3 " " 16	1 " " 63
2 " " 16b	2 " " 72
4 " " 18a	4 " " 108
3 " " 19	1 " " 109
8 " " 20	60 " " 111b
5 " " 22	1 " " 118
3 " " 23	2 " " 126

8 of No. 133

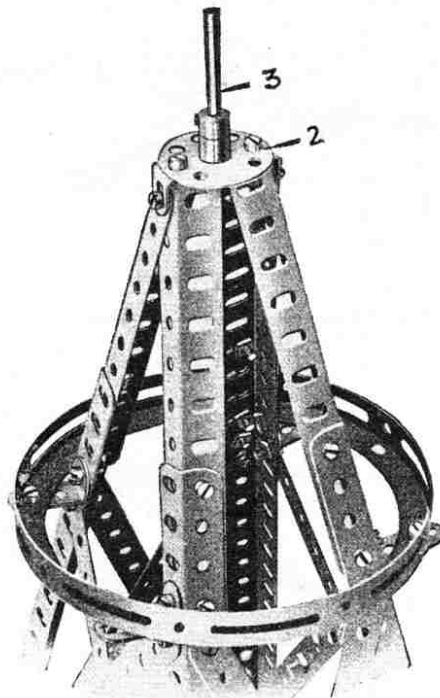

Fig. C. Details of Top of Main Tower

**How to Build the Meccano Chassis**

The Meccano Chassis is a triumph of model-building. At the British Industries Fair it attracted the attention of H.M. the King and was the centre of marked interest to thousands of other visitors to the Meccano exhibit. Fitted with three-speed gear box (with reverse) differential gear, elliptical springing and other modern refinements, the Chassis is an accurate reproduction of the "real thing." So perfectly does it illustrate the main mechanical features of a modern motor car that it is in use at several schools of motoring for demonstration purposes. Full instructions for building this Chassis in miniature are contained in the special leaflet now ready price 4d. post free.

**Electricity** (continued from page 177)

with a simple means of detecting such a current. An instrument called a "galvanometer" is used for this purpose, and in its simplest form it consists of a magnetic needle, very delicately poised, surrounded by a coil of many turns of wire. The effect of the coil is to make the current pass many times round the needle, and this increases the amount of deflection.

If we make a galvanometer with a long coil of very thin wire, having a high resistance, the amount of current flowing through it will depend upon and be proportional to the electro-motive force. Such an instrument, if properly graduated, will measure the voltage of the current, and is called a "voltmeter." On the other hand, if we provide our galvanometer with a short coil of very thick wire the resistance will be practically nil, and by means of a graduated scale the amount of current flowing—that is, the number of amperes—may be measured. An instrument of this kind is called an "ammeter," or "ammeter."

These three instruments, as described, are the very simplest types, and in actual scientific and engineering work more elaborate forms are used to obtain greater accuracy and sensitiveness.

**NEXT MONTH:—**  
**DYNAMOS AND MOTORS**

**£5 for a Model Dragline**

We would remind our readers of the novel Model-Building Competition in which prizes of £5 (cash) and £5 5s. 0d. (goods) are being offered for the best model of a Dragline. Full particulars were announced on page 164 of the June "M.M." Closing date 30th September next.