

FOR THE JUNIOR MECCANO MODELLER

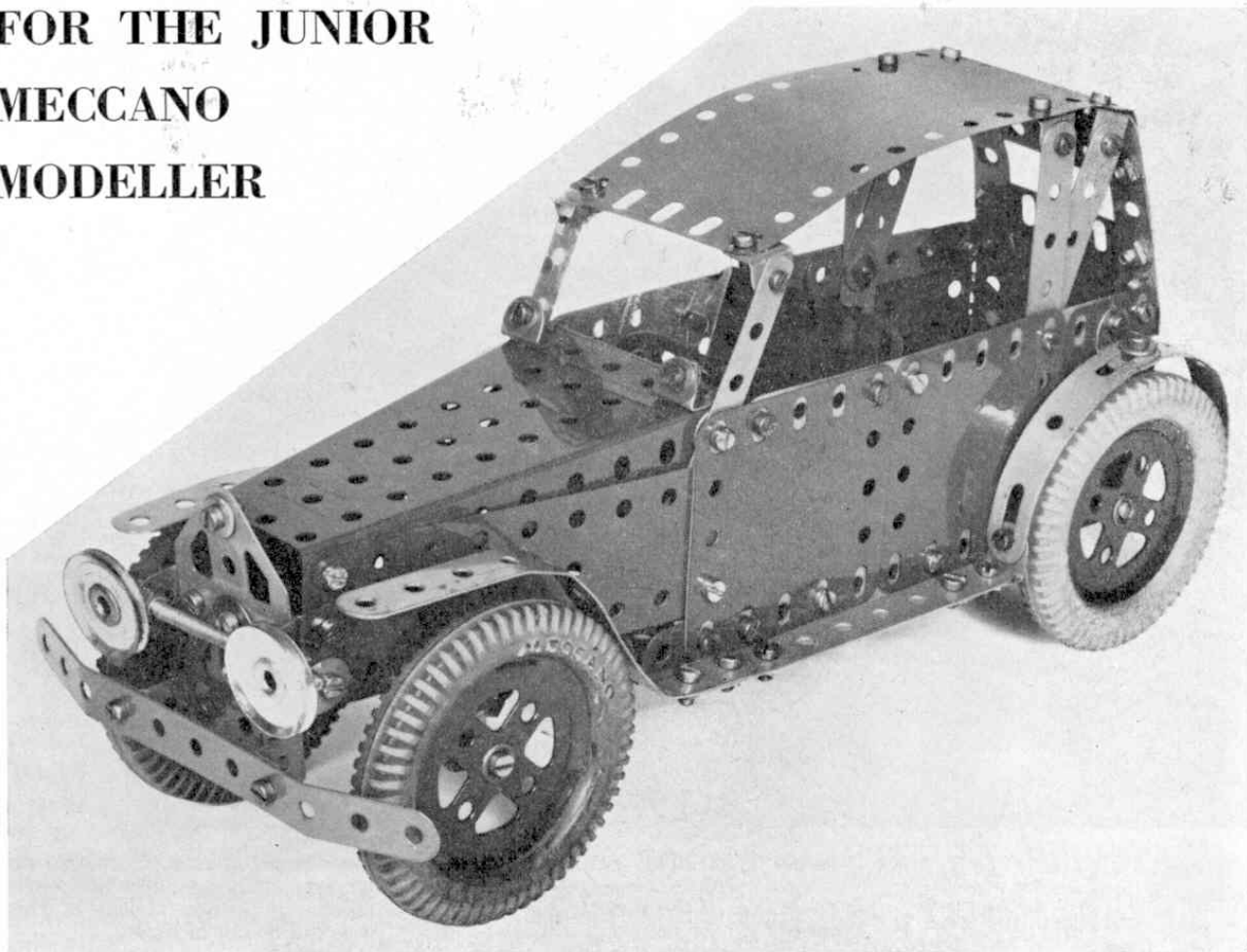

A VINTAGE CAR

WHEN building this model, which is presented on the opposite page in a manner similar to that used in the current Meccano Manuals, there are several points about which special care should be taken. In the steering mechanism, the parts numbered 6a and 11 are lock-nutted to Part No. 5 after being secured to each other by a Nut as shown. In addition, Part No. 212a is loosely fixed to the Coupling on the steering column by Bolt No. 111.

The small diagram beneath the main drawing shows the headlights and steering mechanism viewed from below. The headlamps are fitted by holding the nuts flush against the bosses of the Pulleys and then screwing Rod 80c into them. Trouble will be encountered if this is not done.

Ideas for this model came from what we would now call a drop-head coupe, but which was known years ago as a tourer, i.e. a car which had a folding hood. Although the hood on the Meccano

model does not fold, the look of a tourer with its hood raised has been well captured.

All parts used in the construction of this interesting old car are listed below:

PARTS REQUIRED

7-2, 6-2a, 9-5, 2-6a, 1-10, 2-11, 22-12, 1-15, 1-16, 1-18a, 4-20a, 2-22.
114-37a, 98-37b, 6-38, 1-46, 1-48, 2-48a, 1-51, 1-52, 1-54, 1-59, 1-63, 1-80c.
1-111a, 2-111c, 2-111d, 2-125, 2-126a, 2-142a, 1-185, 3-188, 2-189, 5-190, 1-191, 1-192, 2-193, 2-212, 1-212a, 2-215, 2-235.

FINAL REMINDER

Readers who intend to enter for the current Winter Model-Building Competition and have not yet done so should remember that time is fast running out. The closing date is the 31st of this month, and entries reaching us after that date will be automatically disqualified.

The competition will be split into two sections, A for competitors under 14 years of age on the day of closing and B for competitors age 14 or over on that date. If you have a model you wish to enter, submit either a photograph or a good drawing of it to: Winter Model-Building Competition No. 1, Meccano Ltd., Binns Road, Liverpool 13. Make sure you write your name and address, clearly, on the back of each photograph or drawing, and the letter A or B, signifying the section in which you are entering. Under no circumstances must the actual model be sent.

Full details of the cash prizes to be won were given in last month's M.M. Prize-winning entries are not returnable.

How To Build The Veteran Car: Step-By-Step Illustration

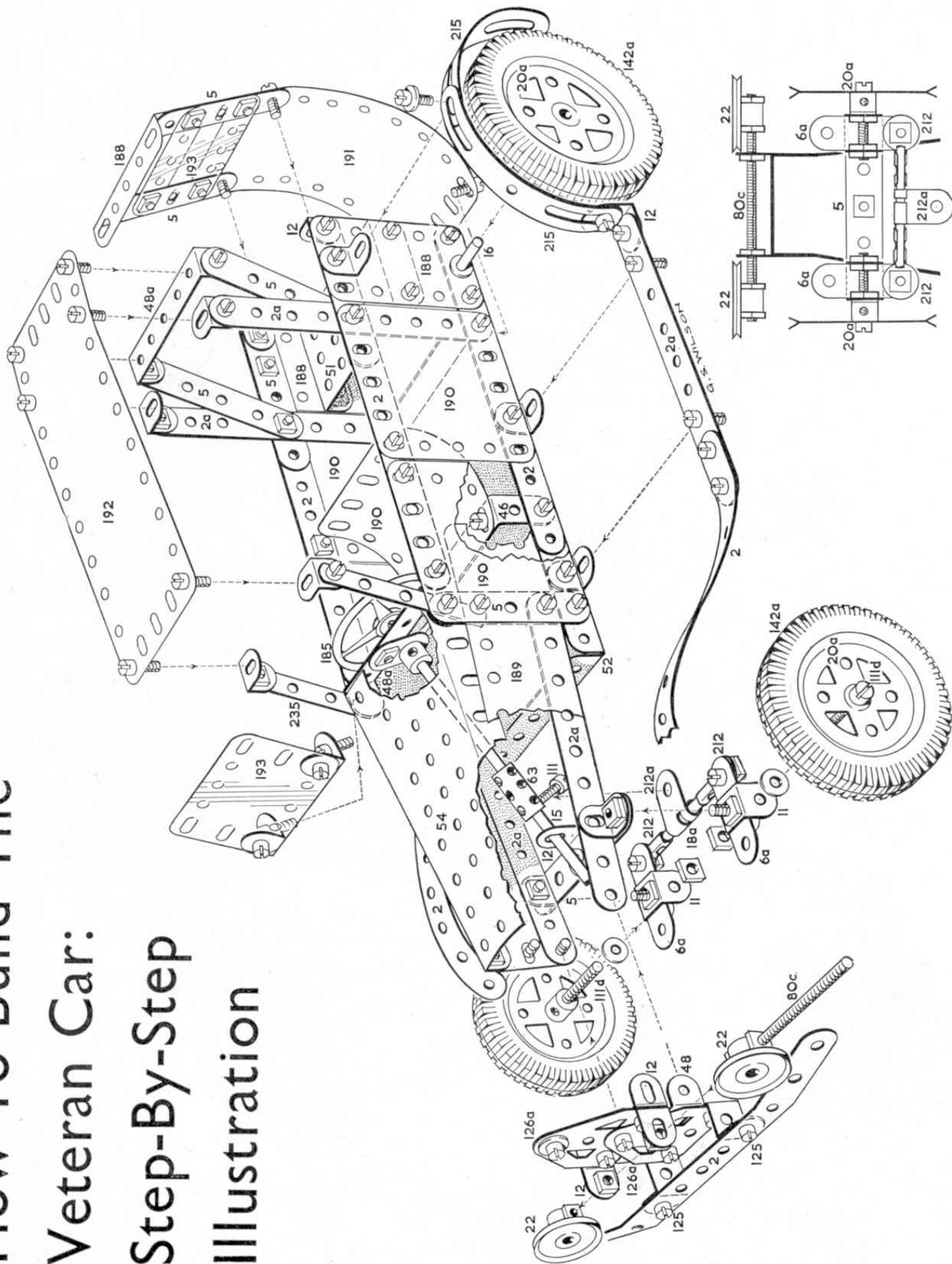

MECHANISMS FOR A MOTOR CHASSIS

Concluding The Special Article By "Spanner"

LAST month, I gave details of several useful mechanisms that could be incorporated in a motor chassis. These were a steering arrangement with independent suspension, a leaf spring suspension unit, a differential, and a 3-speed and reverse gear-box, in that order. A car gear-box, however, is virtually useless without a clutch, which is a mechanism designed to disconnect the drive between the engine and the gear-box so that the gears can be changed.

HEAVY DUTY CLUTCH

The clutch illustrated in Figure 1 is particularly unique in that it can be fitted with from two to eight Compression Springs to vary the pressure between the driving plates to suit almost any model. The heavier the model, the more Compression Springs used.

The driving member is a 1" Pulley fitted with a Rubber Ring, and it is fixed on the input shaft 1. The shaft extends beyond the Pulley, and it passes through a Wheel Disc 2 and into part of the boss of a Bush Wheel 3. The Bush Wheel is fixed on the output shaft 4.

Wheel Disc 2 is connected to Bush Wheel 3 by two Pivot Bolts. Each of these is first passed through the round hole of an Obtuse Angle Bracket 5, and through a hole in the Bush Wheel. A Compression Spring is slipped over the Pivot Bolt, which is then attached to the Wheel Disc by two nuts, one on each side of the Disc.

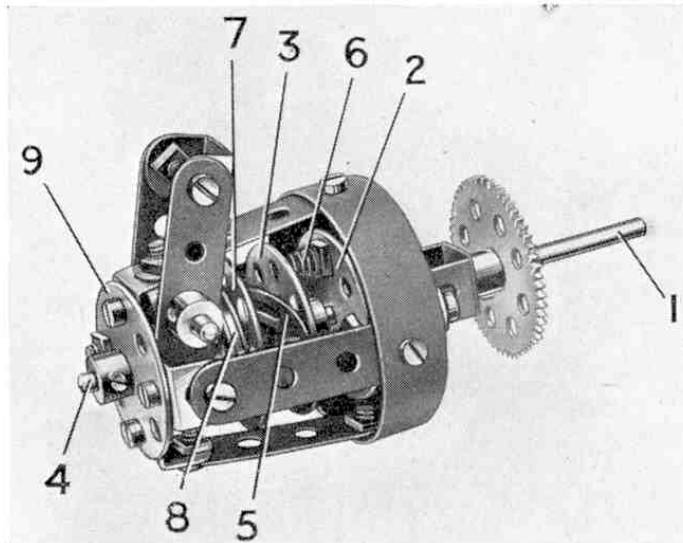

Fig. 1. A compact but very efficient clutch, which can be easily modified by fitting or removing Compression Springs, according to the weight of the model of which it is part.

The Obtuse Angle Brackets are arranged pointing in opposite directions, and they are linked by a short length of Cord that prevents them from flying outward as they rotate with the Bush Wheel. Further Compression Springs 6 can be placed between the Bush Wheel and the Wheel Disc, and they are slipped over the shanks of bolts held by nuts in the Wheel Disc.

The clutch withdrawal race consists of a Wheel Disc 7, and a 1" loose Pulley 8 separated from the Wheel Disc by a Washer.

The clutch housing is assembled from a Boiler End fitted with four 2" Strips connected by Angle Brackets to a Wheel Disc 9. The input and output shafts are prevented from sliding in the housing by a Collar on each side of the Wheel Disc 9.

Operating levers are formed from two 2" Strips pivoted as shown on a short Rod mounted in a Double Bracket fixed to the housing. The levers are linked at their outer ends by a Double Bracket and a lock-nutted $\frac{3}{8}$ " Bolt. The inner ends of the levers bear against the face of the Pulley 8. Adjustment is obtained by sliding the Bush Wheel 3 on its shaft until the Springs are compressed slightly. When the levers are moved to the left, their action is transmitted through the withdrawal race to the Pivot Bolts, which slide to the left through the holes in the Bush Wheel and carry with them the Wheel Disc 2.

A MODERN BRAKE

A chassis must have some effective way of being stopped and the most efficient brake in common use today is the disc brake which far surpasses the old drum brake fitted to most existing cars. An illustration of a Meccano disc brake can be seen in Figure 2, attached, as you will see, to a different form of front suspension to that described in these pages, last month.

The mechanism is mounted on a back plate provided by a six hole Bush Wheel 1. This is fitted with two Angle Brackets lock-nutted to the ends of twin transverse leaf springs that form the front suspension members. The Bush Wheel 1 forms a bearing for a $1\frac{1}{2}$ " Rod used as a stub axle. This Rod is free to turn in the boss of the Bush Wheel and carries a Collar at its inner end.

Fig. 2. An effective disc brake built entirely of standard Meccano parts, except for a length of flexible wire used, together with Spring Cord, to make a working brake cable.

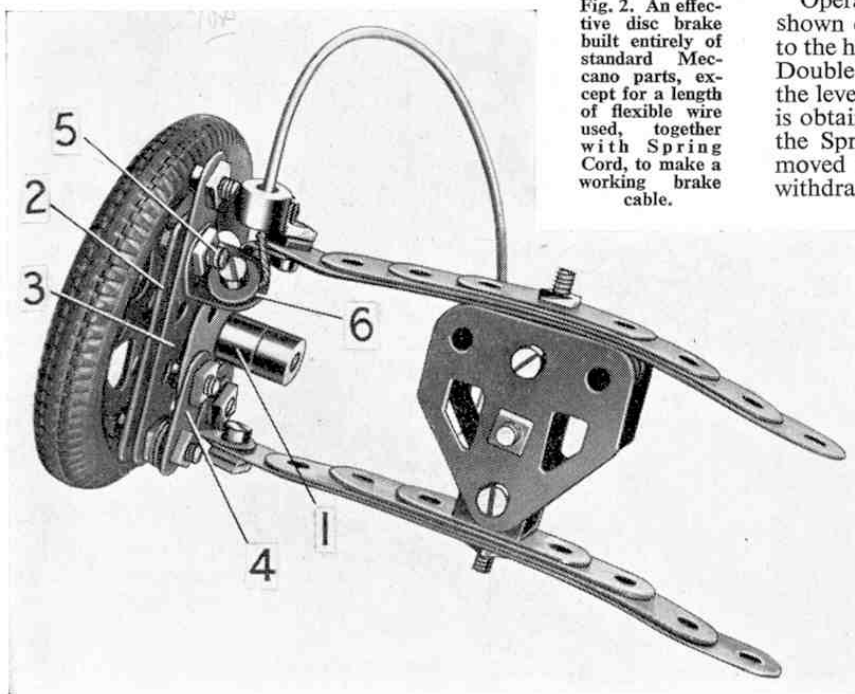

Fig. 3. This twin rear axle drive unit contains two similarly constructed differentials and includes simple leaf springing.

The brake shoes are formed by a 2" Strip 2 and a 2½" Strip 3. They are clamped together at their lower ends on a ½" Bolt, but are spaced apart by a nut placed between the two Strips. A 1" Triangular Plate 4 is bolted to the Bush Wheel 1 after which the ½" Bolt carrying Strips 2 and 3 is fitted with a nut and three Washers, then passed through the Triangular Plate and fixed tightly in place by a nut. A ⅜" Bolt 5 is passed through Strips 2 and 3, and an Angle Bracket 6 is placed on it before a nut is screwed in position. The angle of Strips 2 and 3 is adjusted until the lower face of the Angle Bracket 6 bears against the edge of Bush Wheel 1.

The brake disc is an eight hole Bush Wheel fixed on the stub axle and arranged so that it is free to turn between the Strips 2 and 3. The brake is operated by a length of flexible wire passed through a sheath formed by Spring Cord. At each end, the Spring Cord is gripped in Collars, one of which is screwed on to a ⅜" Bolt fixed by a nut on Strip 3. One end of the wire is bolted to Angle Bracket 6 and the other end is attached to a suitable brake lever. The brake is adjusted by tightening or slackening the nut on the Bolt 5.

A TWIN REAR AXLE DRIVE

Many heavy vehicles today are equipped with two rear axles, both of which are driven by the engine, as these give much better traction and enable heavier loads to be carried. Figure 3 on this page shows such a mechanism constructed in Meccano.

The twin axles are carried by a single leaf spring on each side of the vehicle both of which are made up of one 7½", two 5½", one 4½", two 3½" and two 2½" Strips bolted, at their centres, to a 1½" Angle Girder, which when used in an actual model can be lock-nutted to the chassis.

Each of the axle units is identical in construction. The axle casing consists of halves, formed by two 2½" × ½" Double Angle Strips bolted between a Face Plate and a Bush Wheel. The halves are joined by two 2½" × 1" Double Angle Strips, and a 4½" × 2½" Red Plastic Plate is curved to shape and bolted in position to form part of the differential casing.

The differential crown wheel is a 57-teeth Gear 1, which is free to turn on a Rod mounted in one half of the axle casing. The Rod projects into a Coupling 2, and a ⅞" Bevel Gear is fixed between the Gear 1 and the Coupling. A second Bevel 3 is fixed on a Rod that is mounted in the other half of the axle casing and also projects into the Coupling 2.

Two 1" × ½" Angle Brackets are attached by ⅜" Bolts to the Gear 1, but they are spaced from it by four Washers on each

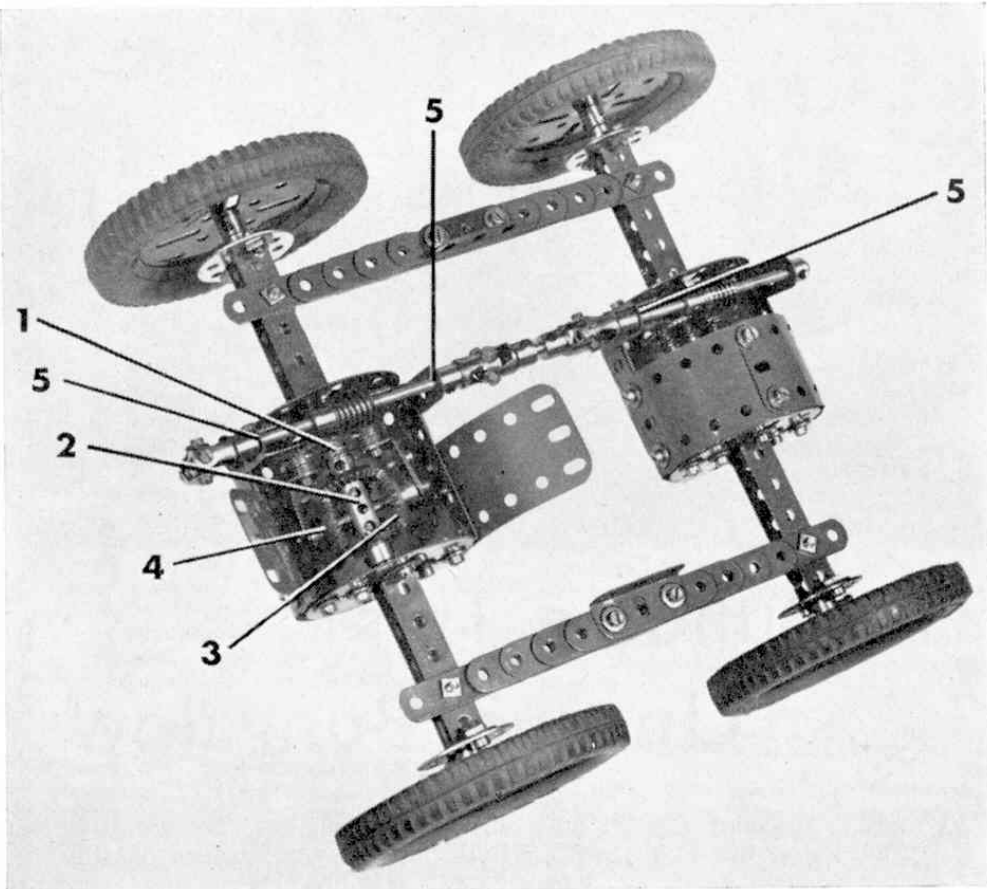

Bolt. A 2" Rod 4 is passed through the 1" × ½" Angle Brackets and is fixed in the centre transverse hole of Coupling 2. A ⅞" Bevel Gear is placed on the Rod 4 on each side of the Coupling and both these Gears are free to turn on the Rod. Fishplates are used to centre the Rod in the slotted holes of the 1" × ½" Angle Brackets.

The drive to the crown wheel is taken through a Worm fixed on a 3½" Rod that is mounted in 1½" Strips 5. These Strips are bolted to the 2½" × 1" Double Angle Strips fixed between the Face Plates. The driving rod of the trailing axle is linked to that of the leading axle by two Universal Couplings and a 1" Rod.

The differential casings are completed by 2½" × 1½" Flexible Plates curved to shape and bolted together, as shown. Note particularly that position of the Worm in relation to the crown wheel is adjusted by means of the 1½" Strips 5 which should be leaning slightly towards the centre.

* * * *

This, then, completes the series but, before finishing, I should like to point out that all the above mechanisms are taken from past issues and publications so it will probably be necessary for you to modify them slightly to suit your own specific requirements. However, you should find them most successful in operation.

Dinky Toy News—

(Continued from page 555)

one overhead light is available, the model should be placed so that the light falls on it at an angle of about 45 degrees. If a second light, such as a table lamp, is available it should be placed a little to one side and slightly in front of the model, and about 3 ft. away from it.

A plain background should always be provided, to avoid confusion with foliage,

brickwork, etc. outdoors, and furniture indoors. For small models a sheet of plain white or brown paper can be used, while for layouts or large groups of models, a white cloth such as a bed sheet is more convenient.

Dark shadows behind and underneath the model can be avoided by arranging sheets of white paper to reflect light on to the dark portion. Lighting conditions vary so greatly it is impossible to be

definite about the exposure time required. If one is available, an exposure meter should be used to determine the correct exposure, otherwise trial and error is the only way. Of course, time and experience will probably enable you to judge roughly what exposure to give a specific scene. When this happens, you are well on the way to being proficient in the art of photographing your miniatures.