

fig.2

Meccano Constructors Guide

by B. N. Love

Reconstruction of original Meccano Motor Chassis which demonstrates basic car mechanics.

PART 10 – VEHICLE MECHANICS

ANY LAD OPENING his Meccano Outfit for the first time will be confronted with a range of parts so suggestive of vehicles that some form of car or lorry will be among the very first of his creations.

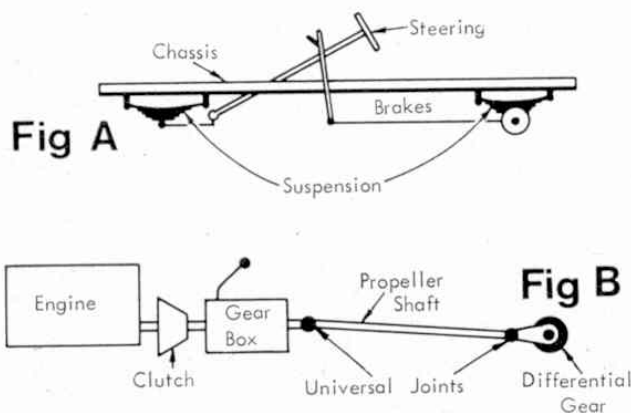

This fever seldom leaves the life-long enthusiast who knows how well the system is suited for demonstrating vehicle mechanics. If we consider two aspects of this topic we might put them in these categories:

(a) Chassis, steering, brakes and suspension, and (b) Transmission from engine to road wheels.

Although the bareness of the diagrams make them more akin to a 1916 Motor omnibus than a 1970 family saloon, the essentials have altered little in the past fifty years. In other words, we need basically, four wheels attached to a frame and a method of propelling the vehicle smoothly and a means for setting it in motion and bringing it to rest while being able to make it follow a non linear path. Considering the chassis before the transmission is literally putting the cart before the horse so we might consider the latter first. Thanks to the Powerdrive motor with its built-in gear box we can install an engine in a Meccano model in a comparatively small space and then proceed to give it realism by building detail around it. At one time the constructor was obliged to use a long sideplate motor which can be seen installed in the original Meccano Motor Chassis, a rebuild of which appears in Fig. 2. Despite the limitation in parts of the period from which this model originates, the basic movements of the motor mechanisms are all reproduced in this model.

Fig. 3 shows what can be done in the way of disguising the Powerdrive motor of modern manufacture by enclosing it in an engine 'block' constructed of Plates, Strips and accessory parts to simulate a heavy duty deisel unit. Fuel lines are easily assembled from connecting wire covered in transparent plastic insulation while standard parts provide generator, breather, dipstick and well, starter motor and cooling fan. A clutch housing is provided by a Boiler End, four 1 in. \times $\frac{1}{2}$ in. Angle Brackets and an 8-hole disc to form the Bell moulding, while particular care has been taken in making the thrust race which is engaged by the clutch dogs to disengage the clutch plate. The two $\frac{3}{4}$ in. Washers sandwiching a 'spider' Collar (Part No. 140Y) which carries four Washers on short Set Screws forms probably the smallest Meccano Roller Bearing. It is very efficient in action.

This particular clutch is somewhat unorthodox in that the Bell housing revolves as a whole, the clutch plate being a 1 in. Pulley with Motor Tyre fixed to the engine shaft. When the clutch pedal is depressed, the Bell housing moves forward bodily, the Boiler End component thus losing contact with the Motor Tyre carried inside it. The clutch shaft is fitted with a Small electrical Bush Wheel at its rear end to engage with a sliding coupling to the gearbox and its forward

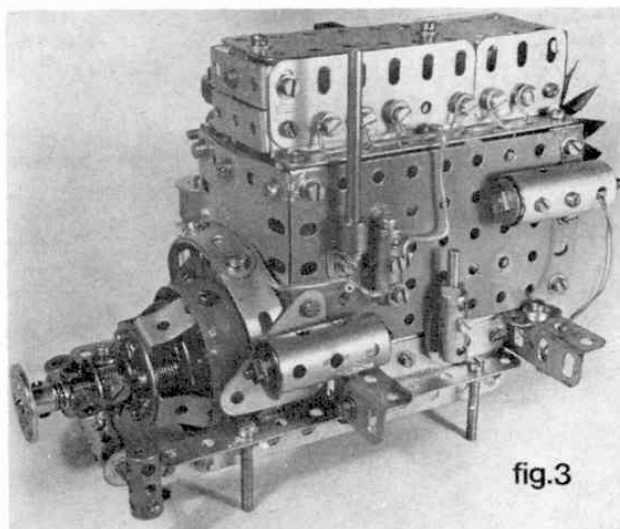

Built up engine block housing Powerdrive Unit.

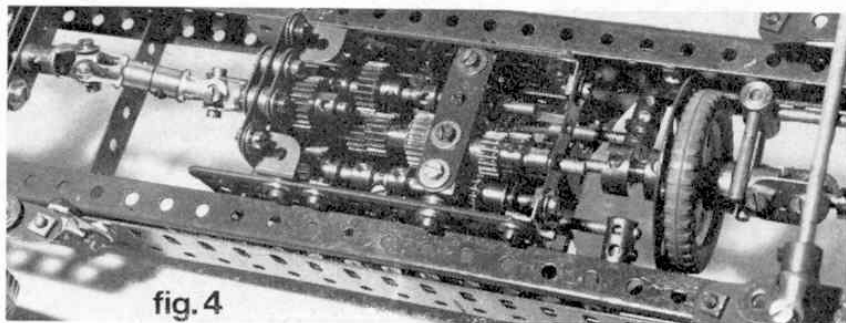

Simple clutch unit on lorry chassis. Note all-Pinion gear-box and universal coupling at rear.

fig.4

end carries the spring pressure 8-hole disc and Bush Wheel, a portion of this shaft being journalled in the clutch housing in alignment with the engine shaft. The inner 8-hole disc is spaced from its Bush Wheel by a lock-nut on each of the compression spring bolts and

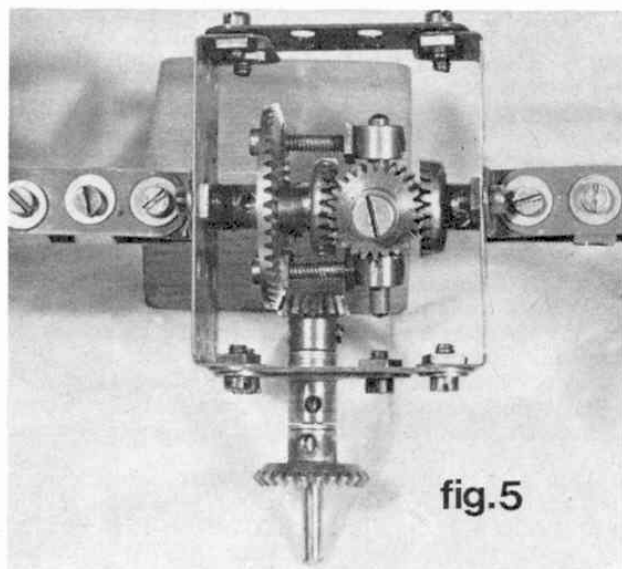

Simple differential gear employing Bevel, Contrate and Pinion Gears.

fig.5

thus forms a free centre for the tip of the engine shaft to enter for alignment. A pressure pad of greased washers may be inserted between this inner disc and the boss of the 1 in. Pulley with Tyre for clutch idling with motor running.

A simpler but perfectly effective clutch unit is shown in Fig. 4. In this case, the clutch plate is a Faceplate connected to the gearbox shaft by a Socket Coupling

and Collar. This provides a hollow bearing through the centre of the Faceplate boss so that the engine shaft can be journalled inside it. The clutch friction disc is a Motor Tyre on a 1½ in. Pulley journalled in a second Socket Coupling which is free to slide on the engine shaft. It is obliged to revolve with the engine shaft by the drive from a pair of Fishplates lock-nutted to the other end of the Socket Coupling as shown in the illustration. The slotted holes of the Fishplates slide on the shanks of Set Screws fixed tightly in a Collar on the engine shaft. A clutch fork is made from two 1½ in. Axle Rods in a Coupling attached to the clutch pedal by link rods. This fork will pull the 1½ in. Pulley with Tyre away from the Faceplate when the clutch pedal is pressed to disengage.

Fig. 4 also shows a compact gearbox based on a non-standard spacing employing ½ in. and ¾ in. Pinions. Twin lay-shafts are employed in this arrangement because of the limited selection of Pinion sizes. The central shaft is split at the centre in a common bearing and three forward speeds plus one reverse are available. Readers are referred to M.M. for April 1969, page 192, for a further explanation of a similar gearbox. The non standard spacing of ½ in. and ¾ in. Pinions in mesh is achieved by using Flat Girders in the construction of the gearbox casing, exploiting the slotted holes to obtain the critical spacing required. Notice that at the output of the gearbox, a universal joint is provided. Fig. 1 shows the normal positions for these joints which are required to make allowance for the difference in level between the rear axle of the vehicle and its gearbox. This difference in level is both a design feature and a consequence of axle movement when the vehicle is travelling. A universal joint is capable of making a junction between the ends of two shafts in such a way that rotation is maintained even when the shafts are at a small angle to one another—drive being available for an angle up to 45 deg. but with decreasing efficiency as the angle increases.

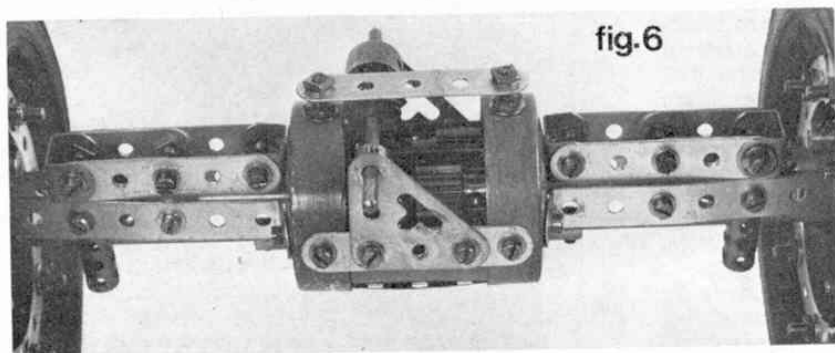

Heavy-duty rear axle unit with spur gear differential.

fig.6

Demonstration front axle drive with flexible joints to road wheels. Note use of Socket Couplings as axle bearings.

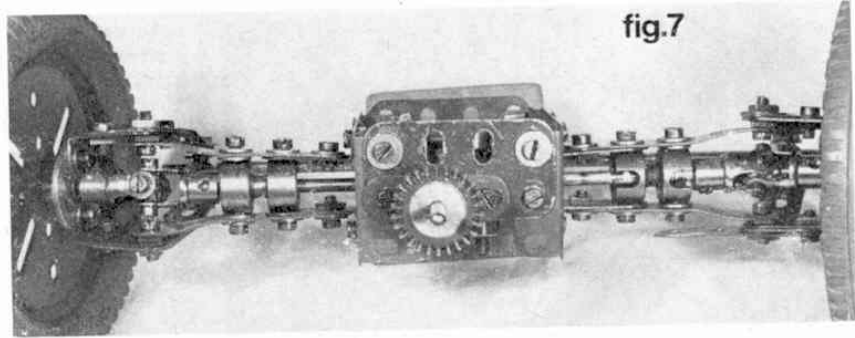

At this stage the transmission from the engine is still running in a line from front to rear and must be turned through 90 deg. if the rear axle is to turn. This could be achieved very simply by using a Pinion and Contrate gear to obtain the necessary right-angle drive as demonstrated in the early chapters of the Constructors' Guide and for very simple models this is a satisfactory way of doing the job. However, when a vehicle changes direction it tends to follow a curved path, as tyre marks in snow or mud will immediately show. This running over curved paths causes the rear wheels to run at different speeds depending on the sharpness of the turn and its direction left or right. Therefore, to permit the rear wheels to turn at different speeds, a differential drive is required and a simple form of this is shown in Fig. 5. Many such differentials have been illustrated in M.M. over its 50 years and more of publication and the gear illustrated in Fig. 5 is a neat combination of bevels, contrates and pinions. A Coupling forms the heart of the differential and receives the inner ends of the 'half-shafts' running to each road wheel, in either end of its lateral bore. The central transverse bore of the Coupling holds a $1\frac{1}{2}$ in. Axle Rod which in turn is bolted to the large Bevel Gear by $\frac{3}{4}$ in. Bolts lock-nutted on Collars as shown. The two 'planetary' 50-teeth Pinions are carried round in 'orbit' by the Pivot Bolts which tie them to the central tapped holes of the Coupling. The two 50-teeth Contrate Gears receive the drive from the Pinions and pass it on to their respective road wheels. If the vehicle is travelling in a straight line on a flat surface, both rear wheels will revolve at the same speed and the orbiting planet Pinions will be carried round by the large Bevel Gear, known as the 'crown' wheel, but the Pinions will not revolve on their Pivot Bolts. If, on turning a corner, one rear wheel is turning faster than the other, the planet Pinions will commence to turn on their bolts and in so doing will pass on a 'differential' motion to the two half-shafts comprising the rear axle. An appreciation of this is far more easily demonstrated by making up the mechanism than by attempting to describe its working in print.

An important feature in mounting differential gearboxes on rear axles is to ensure that they are rigidly attached to axle tubes which are in turn secured to the springs of the vehicle. Fig. 6 shows a rugged construction of a differential gear case suitable for a heavy duty model lorry. Boiler Ends provide strong journal plates for the axle tubes and half-shafts which run out from the differential. By a suitable selection of Double Angle Strips, Double Brackets, etc., the reinforced rear axle assembly shown will carry considerable torque and is designed to receive hub reduction gear at its extremities. Under these conditions, a model would be reaching a very advanced state. The actual differential shown is known as a spur differential because spur or Pinion gears are used. The principles do not

change, however, long and short faced Pinions being employed to obtain the necessary meshing arrangements. In this particular instance, a Helical 'crown' wheel is employed to turn the differential carrier and this allows a top meshing Helical to pass the drive 'over the top' making it a simple matter to engage the drive to a second differential if twin rear axles are employed.

Fig. 7 shows a drive arrangement for a front axle where the road wheels are required to steer. Under prototype conditions a special flexible joint is required to pass on a steady drive to the front wheels at all angles of steering. The geometry of the simple universal joint shown in Fig. 7 falls short of this requirement, a special slot and ball joint being required. This can be partially simulated in the Meccano system by engaging a Handrail Coupling, fitted with a Keyway Bolt, in the open end of a Socket Coupling. This does not give a true ball joint through 360 deg. of drive however but the arrangement shown in the illustration is adequate for demonstration purposes. Note the use of Socket Couplings as rigid bearings in the axle tubes. Basic steering on non-driven front axles has been illustrated frequently in various Meccano articles and a further example is shown in Fig. 8. In

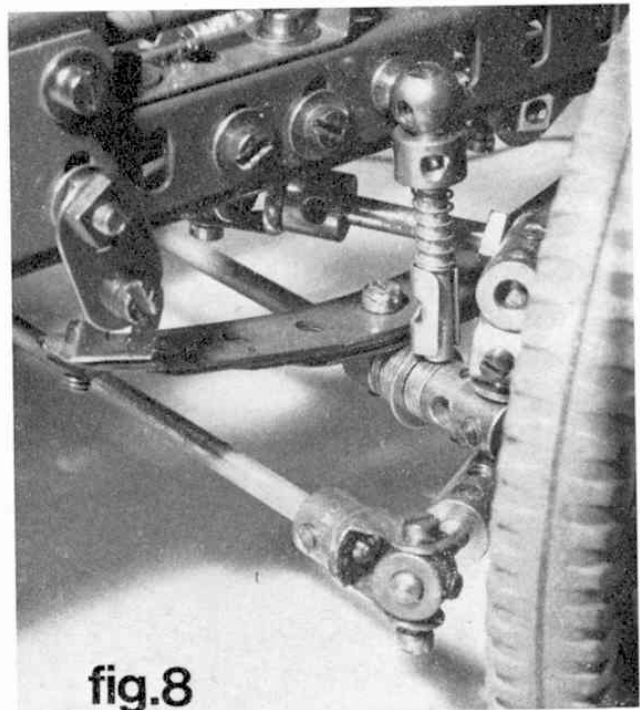

Steering gear fitted with simple coil spring shock absorber.

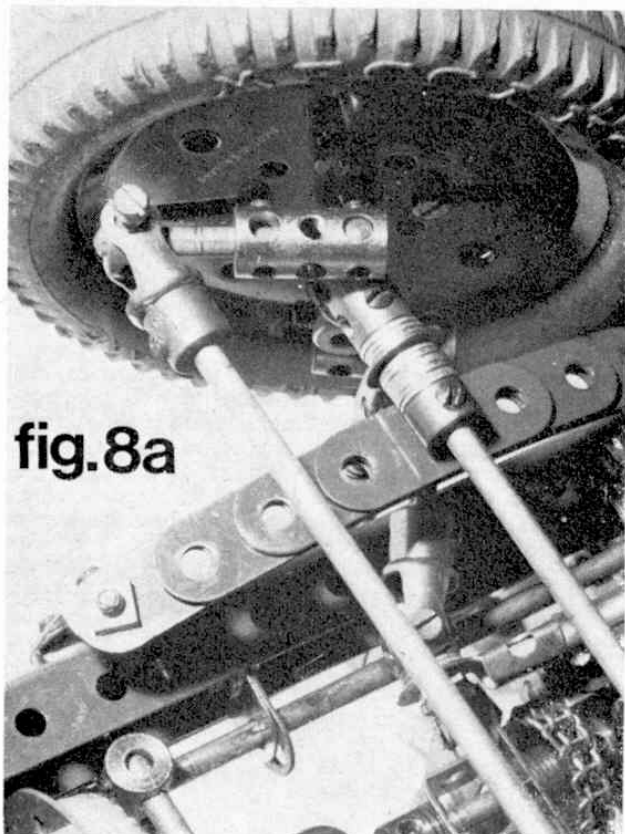

fig.8a

Arrangement of leaf springs and front axle rod securing collars to centre of springs.

this case an Axle Rod is used for the main axle beam which is secured to the leaf springs by Collars. Short Couplings at each end serve as Kingpin journals and the track rods which link one wheel hub to the other

Tipping section of heavy lorry for earth moving. Note curved shape under bodywork.

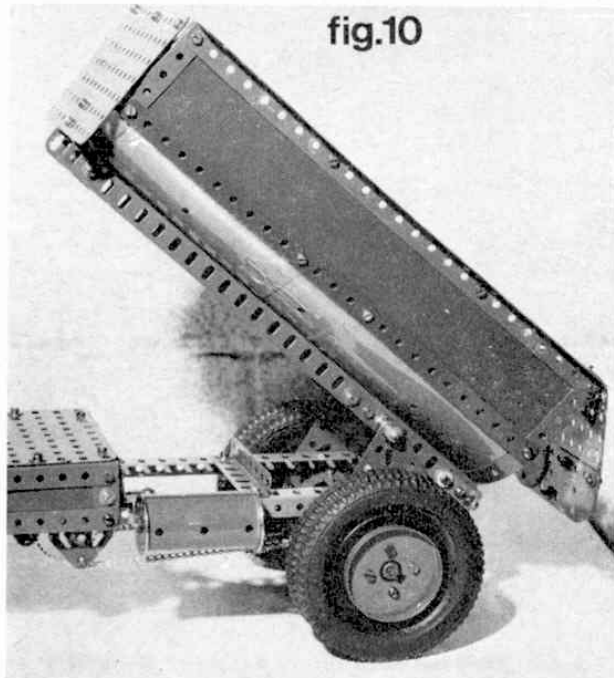

fig.10

are terminated in Swivel Bearings. An interesting feature in Fig. 8 is the provision of a coil spring shock absorber. A 1½ in. Axle Rod pivots in a Rod and Strip Connector on the main Axle and carries a Compression Spring held in place by a loose Collar. A handrail Support, lock-nutted to the chassis, allows the 1½ in. Axle Rod to ride up and down in its transverse bore to cushion the bumps from the main leaf springs.

A form of coil spring suspension is shown in Fig. 9 applied to a neat model of a veteran car. In this case the front axle beam is made of two or three thicknesses of Perforated Strips pivoted at the centre just below the bonnet. Cranks are bolted to each end of the beam to form journals for the Kingpins which are reinforced from below by a cross-strut made from further Perforated Strips. The chassis bearers on either side of the radiator are fitted with Long Threaded Pins pointing downwards, each fitted with two Compression Springs, the tips of the Pins penetrating the axle beam at which point the Compression Springs are trapped in place.

Vehicle features in general offer considerable scope to the Meccano modeller as the veteran car radiator details illustrate in Fig. 9. Coiled Tension Springs in this case give a very realistic appearance while the sharp bends in the Flexible Plates gives a really veteran look to the model.

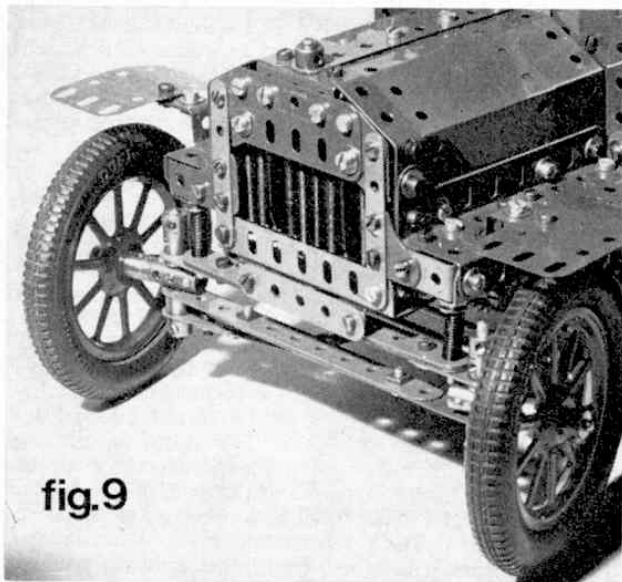

fig.9

Simple front axle unit for veteran car employing central axle pivot and coil spring suspension.

Commercial vehicles are always popular and with so much motorway construction in progress, the tipper is a common sight these days. Nothing spoils the appearance of such a model as a tipper section which is badly designed or full of holes and the example shown in Fig. 10, although quite simple, makes a neat job of tipping. This is largely due to the use of overlapping flexible plates to give a curved under-belly to the tip unit with a minimum number of protruding bolt shanks to prevent smooth discharge of spoil. A further feature is the gravity tail board, hinged from the top edge and neatly curved at its lower edge to conform to the tip-body contours. Twin rear wheels are fitted to the vehicle and nicely finished with Wheel Flanges. The tipping motion, which is controlled from the driver's seat is via the motor gearbox and Sprocket Chain.

Meccano Constructors Guide

by B. N. Love

Part II Further Vehicle Mechanisms

EFFICIENT STEERING ON MODERN high-speed vehicles demands careful attention to 'Steering Geometry' in the design stages to ensure minimum tyre wear, good road holding and cornering properties and the least driver fatigue. The parallel arm steering common to most vehicles has been demonstrated in Meccano parts on many occasions but the combination of those features required for accurate reproduction is not easily achieved with the standard parts at the disposal of the Constructor if he is to keep his models within reasonable scale size, viz a viz prototypes.

Fig. 1 shows what is known as Camber Angle on a front wheel in which the centre line vertically through the tyre is set at an angle to the King Pin. The first advantage of this is that the centre point of contact

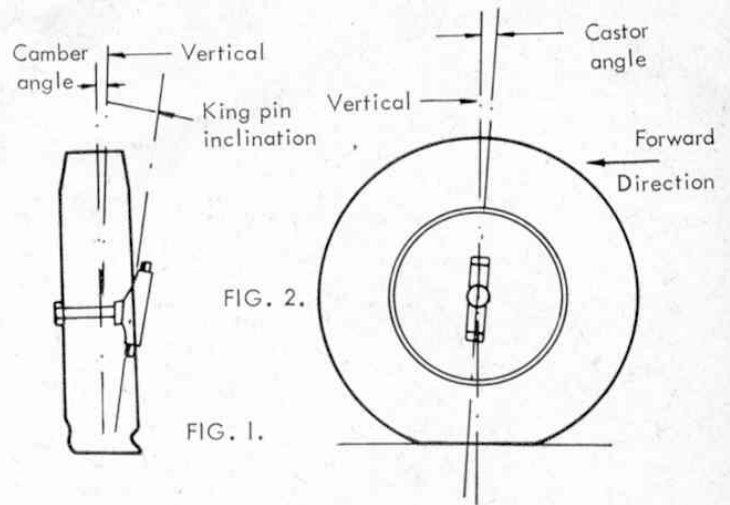

of the tyre section on the ground will coincide with the turning axis of the King Pin, or nearly so, which means that the wheel is steered, in the stationary position, almost on a single spot instead of through a wide arc which would produce steering 'drag' and driver fatigue. At the same time, tyre wear is reduced as the geometry involved reduces 'scrubbing' of the tyre tread.

Fig. 2 shows another important aspect of front wheel mounting known as Caster Angle. A glance at a four-wheeled porter's trolley on a railway station will quickly show that all four wheels are castored, i.e. fitted in forks with a pronounced trailing effect. This ensures that an initial push or pull on the trolley will align the wheel directions to that of the line of effort. The slight tilt to rear of the King Pin shown in Fig. 2 is sufficient to provide castor action in the steering geometry so that, after cornering, the car will tend to straighten up, the steering wheel returning to central position without effort on the part of the driver.

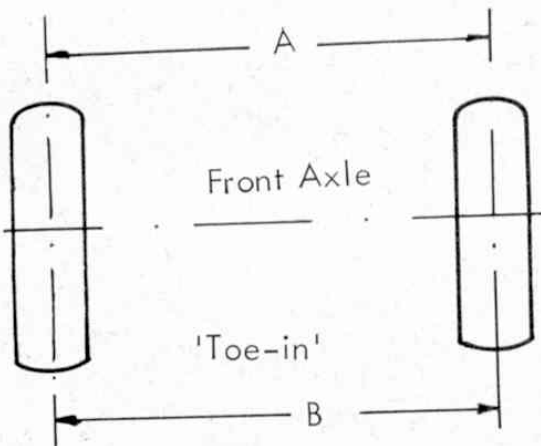

FIG. 3. Dimension A is less than B

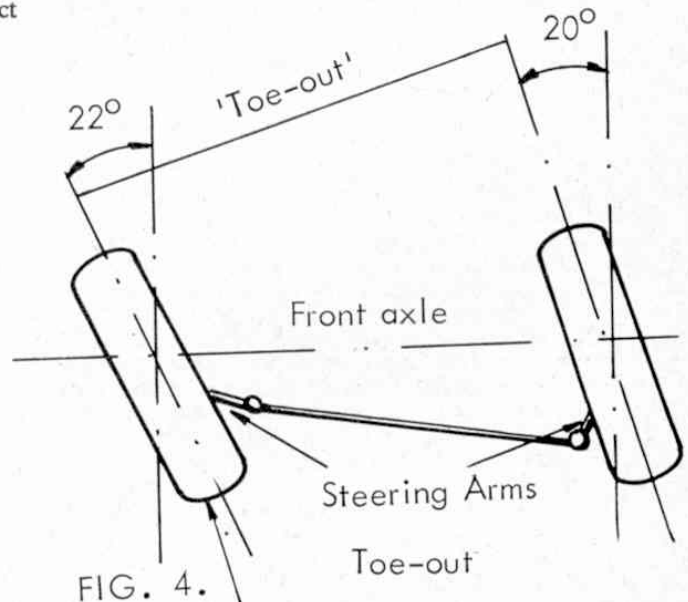

FIG. 4. Wheels turn through different angles when cornering.

Steering linkage comprising track-rod, steering arm, drag link and drop arm.

It is sometimes mistakenly thought that this self centring of the steering wheel is caused by splaying open the front wheels slightly to produce the same effect. On the contrary, in the stationary position, the front wheels of a vehicle have a very slight inclination towards each other rather than being splayed apart. This feature is known as 'toe-in' and, although such an adjustment is measured in fractions of an inch, it is sufficient to provide a counter against the tendency of the front wheels to splay apart under normal travelling conditions and thus prevents unwanted strains on the steering mechanisms and links.

It may be confusing at this stage to point out that once the steering wheel is turned, the front wheels will immediately start to 'toe-out'. Fig. 3 shows the 'toe-in' alignment and Fig. 4 shows the 'toe-out' condition when cornering. It will be noticed from Fig. 4 that the inside wheel, when cornering, is turned through a sharper angle than that of the outside wheel. The

Meccano steering hub capable of 'castor' angle adjustment.

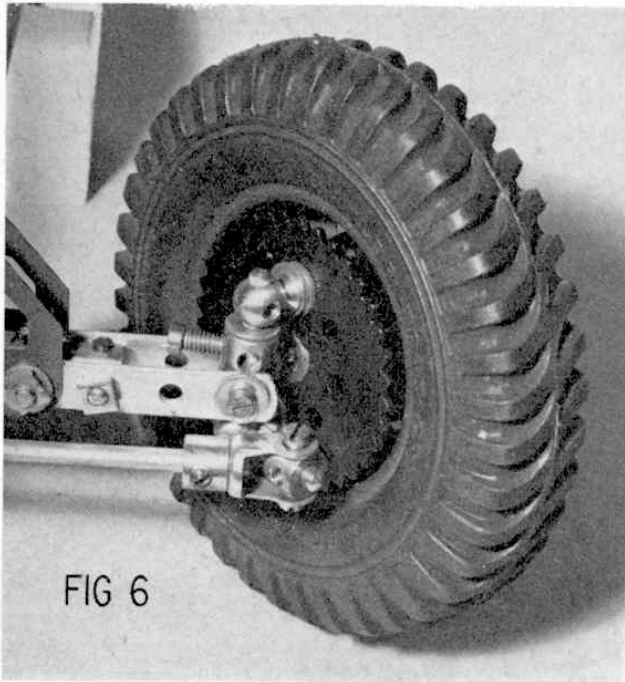
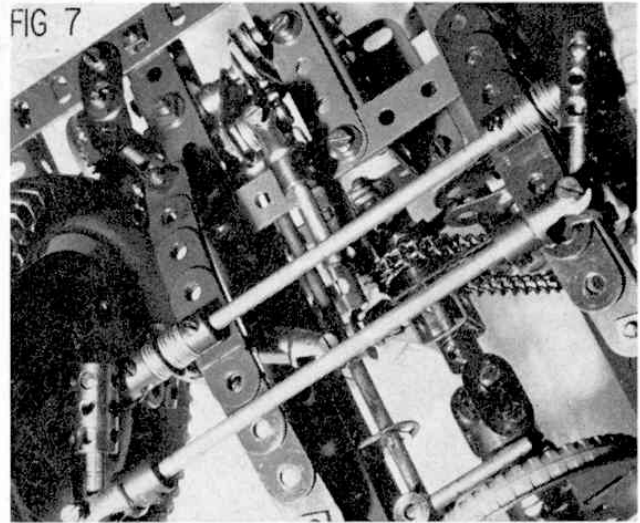

FIG 6



reason for this is that the front wheels of a car will complete two turning circles in a full turn, one circle being inside the other. Fig. 5 illustrates this and shows why the wheel describing the smaller circle requires a greater angle of turn. This is achieved by setting the steering arms of the front wheels at a pre-determined angle, as shown in Fig. 4.

Fig. 6 shows a method of making a steering hub in Meccano parts. The hub flange is a 2 in. dia. Sprocket Wheel fitted with a pair of Handrail Supports. These carry a 1 1/2 in. Axle Rod to act as the King Pin which is journalled in a Short Coupling attached to the extreme end of the axle. By packing out the top Handrail Support with Electrical Brass Washers, camber angle can be achieved. The 1 1/2 in. Axle Rod must be free to pivot in the Short Coupling which is secured to double thickness Narrow Strips by Set Screws packed with a Washer to prevent the shank of the Set Screw from binding with the Axle Rod forming the King Pin. The lower Handrail Support is fitted with a short Threaded Pin in its tapped hole and the shank

FIG. 5.

Diagram to show need for inside wheel to turn at sharper angle than offside wheel when cornering.

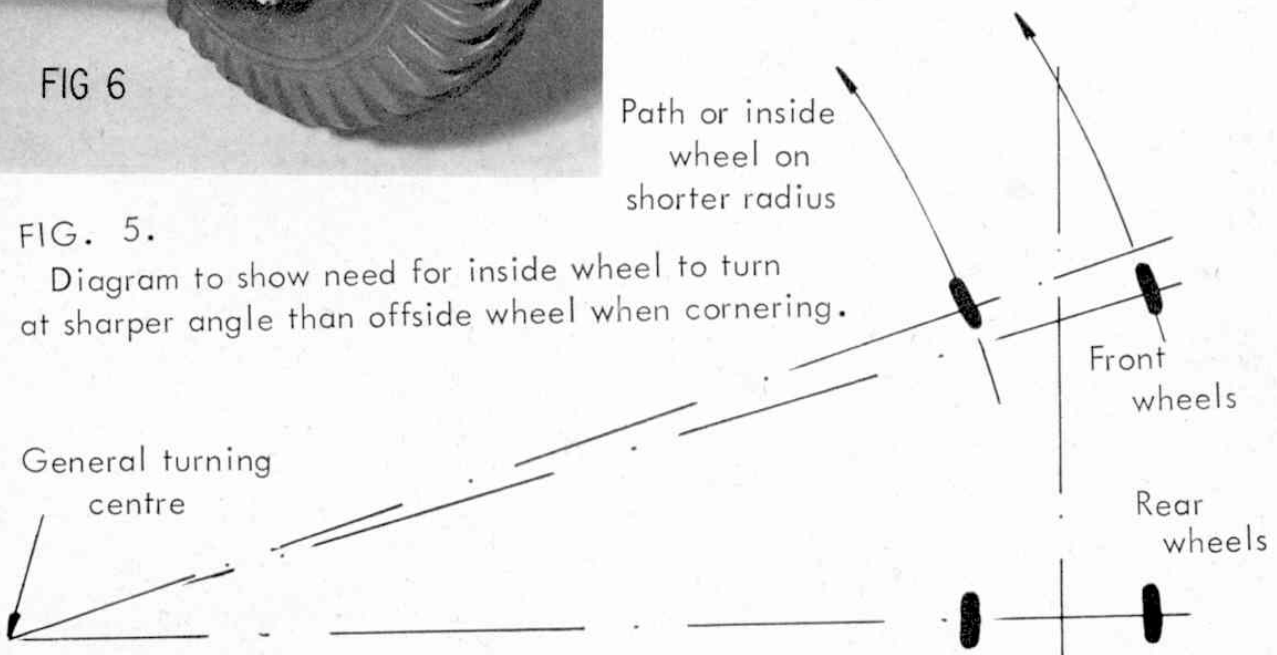

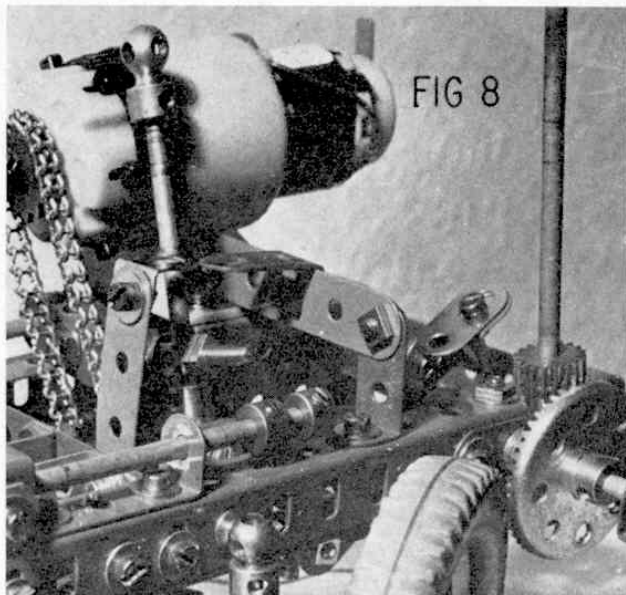

Forward-mounted steering column suitable for model buses, etc.

of the pin forms the steering arm to which the track rod is attached by a swivel Bearing. This arrangement gives a wide angle turning 'lock' and compact swivel joints. The angle of the Short Coupling forming the King Pin journal may be adjusted as follows: Fig. 6 shows a long-shank Bolt screwed into the upper tapped hole of the Coupling to indicate its alignment. By replacing this Bolt with a Screwed Rod and securing the inner end of the Rod near the axle centre by means of a Threaded Boss, Coupling, etc., a small degree of 'positive' or 'negative' tilt can be set on the King Pin and locked by nuts to a rigid setting. The spinning wheel hub carrying the tyre is simply a Boiler End fitted internally and/or externally with Bush Wheels to centre it, the tyre being a neat push fit on to the Boiler End.

A further system of track rod connection is shown in Fig. 7 where Couplings are employed at the lower end of the King Pins. These may be set at an appropriate angle for 'toe-out' (see Fig. 4) to give the correct turning geometry. In this arrangement, the steering arm linked to the steering column is carried at the top of the King Pin on the off-side of the chassis and runs between the elliptical springs and chassis member above. The steering arm is fitted with a drag link making use of Collars, Rod and Strip Connectors and Swivel Bearings to join up with a Crank acting as the drop arm from the steering gear. A further view of the steering column gearing is shown in Fig. 8 where it is seen mounted almost at the front of the chassis, typical of modern bus steering, the 19-teeth Pinion giving a reduction drive to the drop arm. The 19-teeth Pinion can be replaced by a 15-teeth or even a 13-teeth Pinion from the Meccano Clockwork Motor if a lower reduction is required between the steering column and the Contrate Wheel which operates the drop arm Crank.

Braking systems can be incorporated in Meccano vehicles by utilising Wheel Flanges or Boiler Ends as brake drums. Fig. 9 shows a simple internal expanding brake in which the bosses of two Cranks slide outwards in the slots of a Faceplate attached to the rear springs. A 2½ in. Perforated Strip forms the brake lever and

the Crank arms are pivoted on lock-nutted bolts attached to the brake lever in such a way that a forward movement of the brake lever drives the Crank bosses outwards to bind against the inside of the Wheel Flange. These bosses are sprung inwards for return motion by a short Rubber Driving Band linking them together.

More positive braking action can be achieved by making brake shoes from several thicknesses of Pawls without bosses, Part No. 147c. If these are locked on to a short Screwed Rod pivoting in the boss of a Threaded Crank attached to the wheel hub, a strong braking effect may be transmitted to the Pawls by an external lever. It is even possible to make fibre brake shoes by using 1½ in. Insulating Perforated Strips bolted together or pivoted in stacks on Pivot Bolts inside the brake drums.

Simple brake cables may be formed from Loom Healds, Part No. 101, as shown in Fig. 9a and these are strong enough to provide considerable braking effort. A flexible brake cable can be made up from Meccano Spring Cord, Part No. 58, and for demonstration purposes, Electrical Tinned Copper Wire may be used running down the centre of the Spring Cord which would be anchored in Collars at either end of the brake line. Copper wire stretches quite easily how-

Simple internal expanding brake suitable for demonstration purposes.

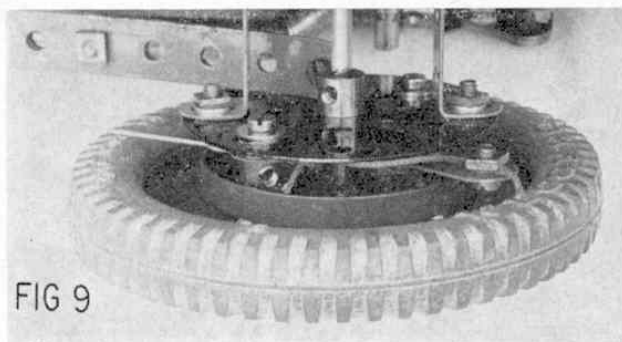

Hand brake lever suitable for operating vehicle brakes employing wire Loom Healds as brake cables. The Crank transmits identical braking effort to the far side of the chassis.

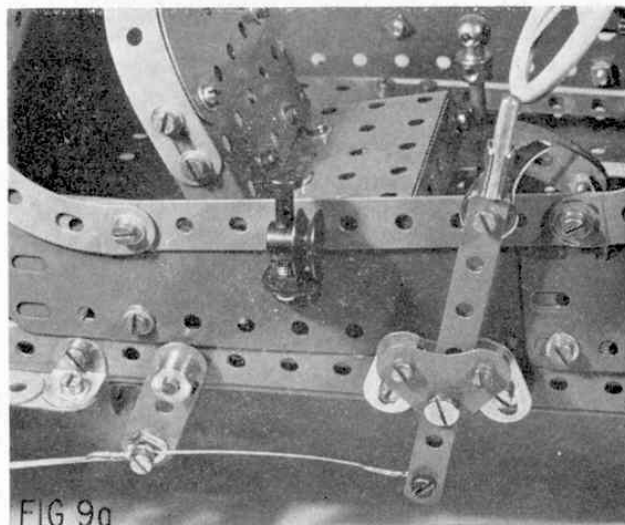
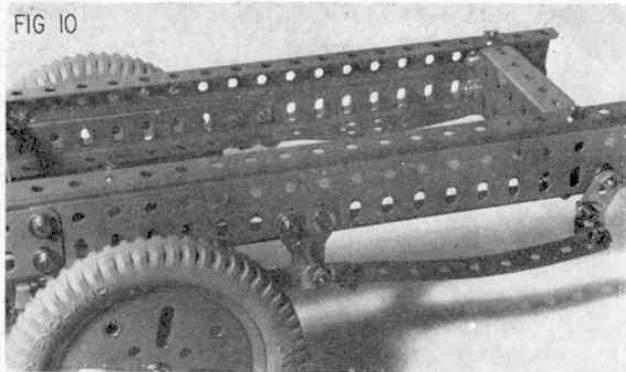
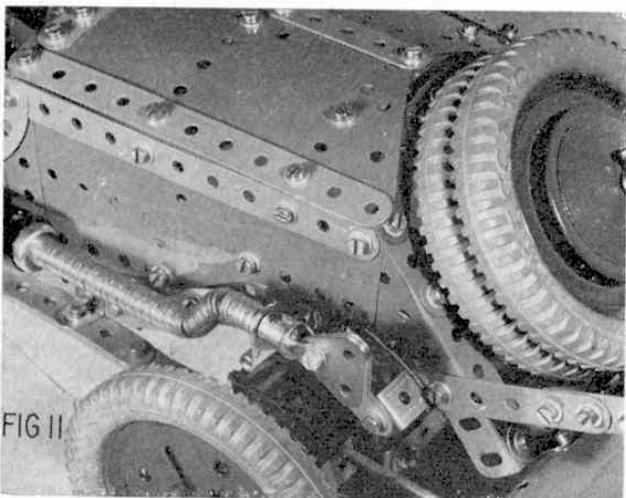

FIG 10



Lorry models should be provided with substantial chassis members as shown in the illustration.



'Tail-end' modelling of an early type sports car. Note twin spare wheels and tapered faring at rear of luggage boot.

ever and steel wire is preferable—that used in stringed instruments being ideal for the purpose.

Chassis construction for commercial vehicles should be rugged as in the prototypes and Fig. 10 shows one made up in channel girders with skeleton arrangement of leaf springs to indicate wheel spacing at the rear of a heavy duty lorry. Once the wheel arrangement is satisfactory, the leaf springs may be reinforced with additional Perforated Strips or built up from Narrow Strips to give a more pleasing scale.

If leaf springs are employed in Meccano models, they should be compatible with the size of the vehicle as far as possible and care should be taken to support the springs at their ends by well-designed shackles which will keep them aligned but will also permit them to bend under load. Our roads are well used by large vehicles and the observant constructor will note how the springs vary according to size and class of vehicle, many of the heavy commercial vehicles having their springs exposed below a fairly open structure of the chassis.

One type of popular spring which works well in Meccano vehicles is the cantilever spring. This is an 'upside down' spring which has its forward end and its centre secured to the chassis and its trailing end is attached to the rear axle as shown in Fig. 11.

Considerable detail can be modelled into Meccano motor cars and lorries, by the careful selection and use of parts. Fig. 11 shows a neat construction of a heavy 'sporty' type exhaust system using a large number of Washers on Axle Rods and Crank Handles, a 'fishtail' being supplied by three 1 in. Triangular Plates locked in an End Bearing.

Figs. 12a and 12b show how fairings can be moulded from triangular and rectangular Flexible Plates and how a badge bar with large headlamps can set off a stylish radiator. Constructors who favour the Bentley/Bugatti/Aston Martin vintage models will appreciate the difficulties in modelling details. Fig. 12b shows an unorthodox use of Tension Springs in providing flexible feed-out pipes from the exhaust manifold to the main exhaust line. The E15R Motor used in the model shown has base flanges with slotted holes. The small twisted loops at the ends of standard Tension Springs, as supplied, lock into the slots with a simple twist and no other form of securing is required.

Next month's article will deal with Electrical Parts in the Meccano System and this will conclude the Constructors' Guide Series.

An example of 'vintage' bodywork on a veteran chassis utilising Flexible Plates to model body contours and various parts in unorthodox applications.

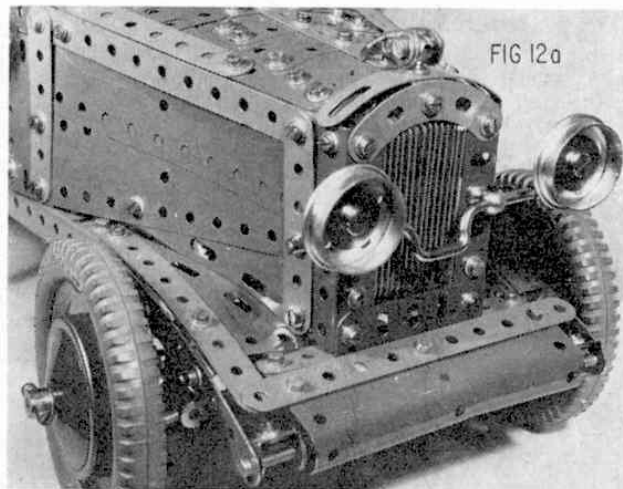

FIG 12a

'Open-sided' exhaust details making good use of Meccano Tension Springs in an unusual manner.

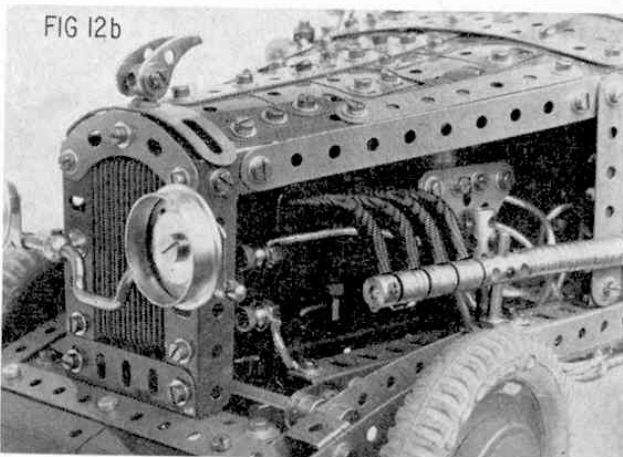

FIG 12b

MECCANO CONSTRUCTORS GUIDE

by B. N. Love

Part 12

ELECTRICAL CIRCUITS FOR MOTORS AND LIGHTS

SO MANY TYPES of electric motor have been available to the Meccano enthusiast over the years that he may well be confused at times as to what is required in the way of power supplies and, as the number of transformers and controllers is equally profuse, a short explanation of general requirements may help to clarify the matter. Essentially, two types of Meccano motor are available to the constructor, one being known as a "universal" type and the other as a D.C. type. For a period of some 40 years or more, Meccano Ltd. produced the first type in large quantities and in several patterns, a selection of which are shown in Fig. 1. These are all known as 'side plate' motors with the exception of the spherical enclosed motor which is affectionately known as a 'cricket ball' type.

All these motors are of the "Universal" type, which means that they may be very conveniently run, via a suitable transformer, from Alternating Current (A.C.) as supplied to houses in most parts of the world, or from Direct Current (D.C.) as supplied by a battery or transformer/rectifier.

Alternating Current is constantly changing direction 50 times per second in most European countries and 60 times per second in the U.S.A. Since an A.C. motor consists basically of an electro-magnetic armature driven by repulsion and attraction from an electro-magnetic set of field coils, the change of direction of current, being the same at any instant of time for both the armature and the field coils, means that the magnetic relationship between the two parts of the motor is constant, in terms of direction of rotation. D.C. motors for model driving, on the other hand, commonly have permanent magnet yokes acting in place of field coils, which means that the field of such a motor is not

reversible. If such a motor had an armature supplied with alternating current it would try to start and reverse 50 times per second which would result in a complete cancellation of rotation—not to mention a probable burned-out armature! The D.C. motor has several advantages however, since it is only necessary to supply current to the armature.

With modern development of nickel alloy permanent magnets, motor fields can be very dense and very compact with long life characteristics—a failing in early D.C. motors for model driving. Hence, a battery, fitted with a switch which will change over the feed wire contacts will operate a D.C. motor in either direction and has the great advantage of portability making the model independent of trailing power supply leads.

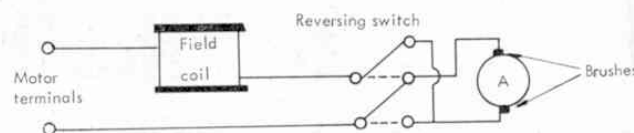
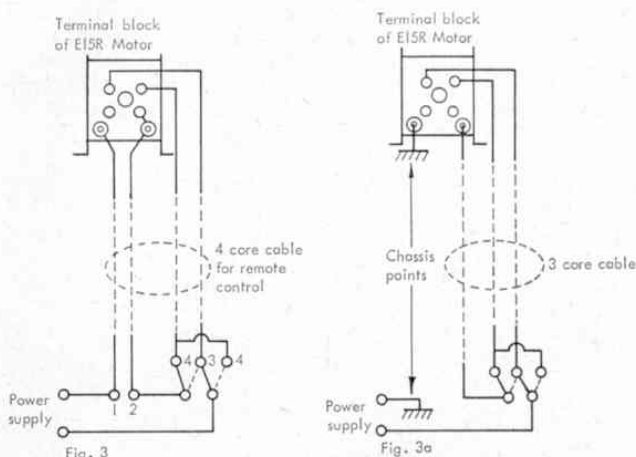
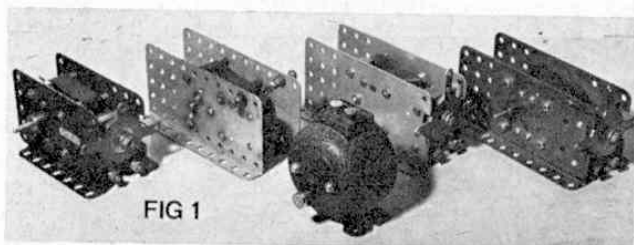

Fig. 2 b. Reverse switching arrangement common to Meccano 6 volt, 15 volt and 20 volt 'universal' (A.C./D.C.) motors.



Alternate methods of wiring the E15R and similar Meccano 'universal' motors for reversing by remote control. Fig. 3 - 4 core system. Fig. 3a - 3 core system with one lead 'earthed' to chassis model. A Double Pole, Double Throw change-over switch is required for the remote reversing.

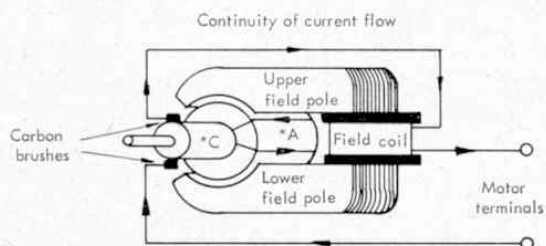

Fig. 2. General arrangement of Meccano 'universal' electric motor showing 'series' wound arrangement for Field coil and armature. *C - commutator *A - armature

Early Meccano motors were intended to be operated from lead-acid accumulators as their current demands and low efficiency made dry battery operation unsatisfactory and very expensive. Four-volt motors were quite common in the early 20's to suit the accumulator but low voltage means high current consumption for the power required. By the late 20's the voltage rating had been increased to 6 volts and attempts made to drive Meccano motors from house mains. Few districts in U.K. were on A.C. supplies and one Meccano motor was manufactured to run from 110 volts, this being supplied from the then 220 volt D.C. domestic supply