

# Meccano Fun for the Christmas Party

## Jolly Toys and Puzzles

THE Christmas season offers a fine opportunity for model-builders to indulge in the lighter kinds of Meccano construction by using their Outfits to make all kinds of mechanical toys and puzzles. Several simple examples of models of this type are described in this article, and these will be found splendid for amusing one's younger brothers and sisters and friends at the Christmas party. All the models dealt with are easy to build, and their constructional details are shown in the accompanying illustrations. Three of them, the walking kangaroo, the "Cum-Bak" and a string puzzle, shown in Figs. 3, 4 and 6 respectively, were described in the Magazine several years ago, but are so interesting that they are repeated for the benefit of present-day Meccano enthusiasts.

The first model, shown in Fig. 1, is a novel toy that was designed by M. LaPipparo, Milan. It is a small "monkey" that can be made to climb vigorously up a piece of cord. The body of the monkey consists of two 3½" Strips joined by Double Brackets at 1 and 2. The bolts that fix the Double Bracket 1 in position hold also the monkey's arms, and the lower Double Bracket is held in position by the 1" Screwed Rod 3. The nuts are left sufficiently loose on the Rod to allow the legs to pivot freely. The legs are made from 2" Strips, with feet consisting of Flat Brackets, and they are connected at 4 by a 1" Screwed Rod lock-nutted in position. The ends of the Spring 5 are looped over the Screwed Rods 3 and 4, and the ¾" Bolt 6 passes through the loop so formed. Two ¾" Bolts are pushed through the Flat Brackets forming the feet and are fitted in place by lock-nuts, one of the Bolts carrying six Washers, which serve as a guide to centralise the cord.

The back of the body is a 3" Strip, which supports a Cranked Bent Strip. The ½" Bolt 7 carries a 1" loose Pulley around which a Spring is looped, the ends of the Spring being anchored on the ¾" Bolt 8.

The monkey is completed by joining the ends of the arms with a Double Bracket and fitting the head in position. A piece of Meccano Cord is now threaded through the last-mentioned Double Bracket, then around the rearmost ¾" Bolt connecting the feet, and up over the second ¾" Bolt. The Cord is fitted at each end with a 1" Pulley.

To make the monkey climb, the cord is pulled taut, thus causing the legs to straighten and move the body upward and

forward. As it does so the Cord is gripped between the coils of the upper Spring. On releasing the tension of the Cord the legs move up under the influence of the lower Spring, and are ready for the next movement.

Parts required to build the Climbing Monkey: 2 of No. 3; 1 of No. 4; 4 of No. 6; 3 of No. 10; 4 of No. 11; 2 of No. 22; 1 of No. 22a; 1 of No. 23; 27 of No. 37a; 10 of No. 37b; 8 of No. 38; 1 of No. 40; 2 of No. 43; 1 of No. 44; 2 of No. 82; 2 of No. 90; 3 of No. 111; 1 of No. 111a; 1 of No. 111c.

An ingenious puzzle always provides much good fun, and one made entirely from Meccano parts should be particularly popular. Such a puzzle is shown in Fig. 6. It is simple to make, but the problem it provides, which is to remove the Strip 2 from the frame, is by no means easy to solve! Cutting the string or undoing the knot is not allowed.

The loop of string 1 attached to the end of the 5½" Strip 2 should be of such a length as to reach half way along the Strip 2. To assemble the puzzle, first pass the loop over the points 3, 4 and 5, and then slip it down to the Trunnion 6. Next pass the loop successively over 5, 4 and 3. The loop 1 and Strip 2 are now attached to the frame as shown in the illustration.

A friend should be asked to remove the Strip 2 from the frame. It looks impossible, and he will undoubtedly find the task difficult.

Parts required to make the Puzzle: 3 of No. 2; 9 of No. 37; 4 of No. 90; 1 of No. 126a.

Fig. 4 shows a very interesting Meccano novelty that never fails to mystify anyone "not in the know." We have called it the "Cum-Bak" and it takes the form of a small drum built up from Meccano parts and is most effective when enclosed in a strip of thin cardboard. If the drum is rolled along a table or smooth floor it will

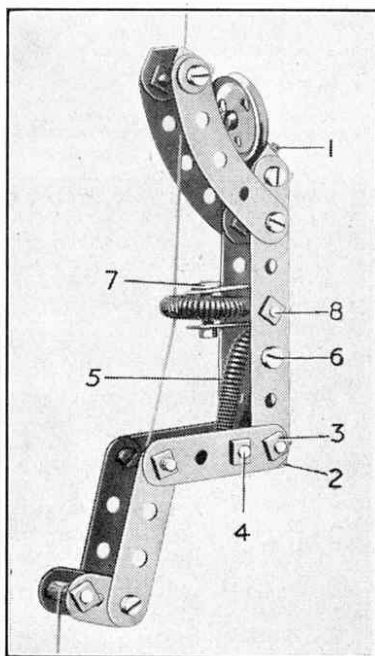

Fig. 1. A Meccano monkey that climbs up a rope.

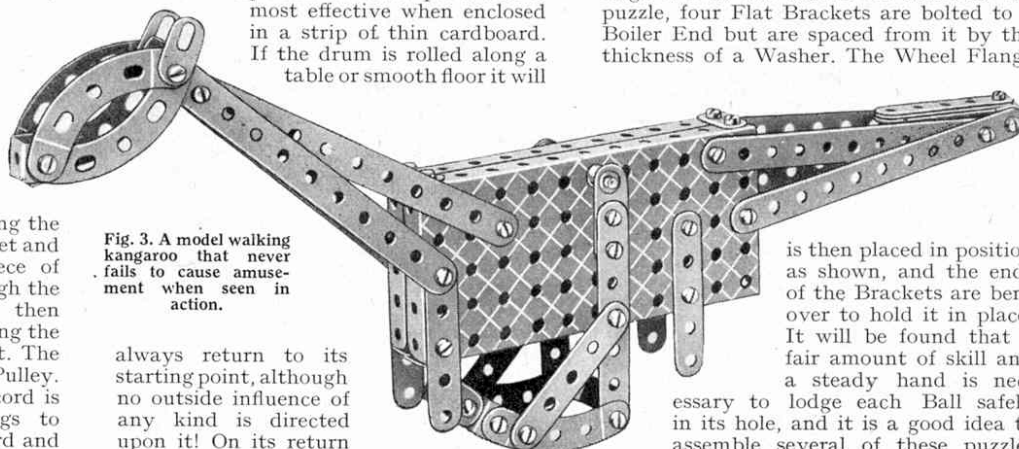

Fig. 3. A model walking kangaroo that never fails to cause amusement when seen in action.

always return to its starting point, although no outside influence of any kind is directed upon it! On its return

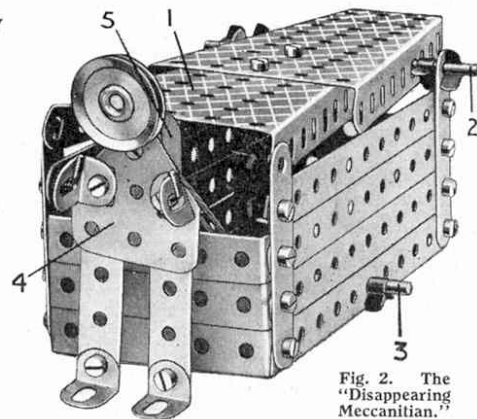

Fig. 2. The "Disappearing Meccanitian."

journey it will sometimes overstep its commencing mark, but after a few oscillatory movements it will finally come to rest practically on the spot from which it started. It will only work on a smooth surface.

The mysterious antics of the "Cum-Bak" depend entirely upon a short length of elastic and a suspended weight. The elastic is doubled and secured between the 3" Pulley Wheels, from centre to centre, and a weight, consisting of any suitable Meccano parts, is attached to it in the middle of the drum. The weight illustrated consists of a 1" loose Pulley and two 1" fast Pulleys mounted on a 1" Rod gripped in the bosses of the fast Pulleys.

As the drum rolls along the weight tends to remain in its original position and the elastic therefore becomes twisted. The resistance in the elastic retards the drum to an increasing extent and finally stops it. The effort of the elastic to return to its former state then causes the drum to roll in the opposite direction. By the time the elastic has regained its normal position the drum has gathered a certain momentum, which usually carries it a little way past its starting point. It soon returns, however, and after a few short rocking movements finally comes to rest practically at the spot from which it started its journey.

Parts required to build the model "Cum-Bak": 1 of No. 18b; 2 of No. 19b; 1 of No. 20; 10 of No. 37a; 14 of No. 37b; 4 of No. 48b; 5 of No. 59; 1 of No. 186a.

Another simple Meccano puzzle is shown in Fig. 5. It consists of a Wheel Flange in which are placed four Steel Balls, and the object is to get all the Balls in the four small holes in the Wheel Flange without allowing any of them to drop through the large hole in the centre. To assemble the puzzle, four Flat Brackets are bolted to a Boiler End but are spaced from it by the thickness of a Washer. The Wheel Flange

is then placed in position as shown, and the ends of the Brackets are bent over to hold it in place. It will be found that a fair amount of skill and a steady hand is necessary to lodge each Ball safely in its hole, and it is a good idea to assemble several of these puzzles

# Meccano Fun for the Christmas Party

## Jolly Toys and Puzzles

THE Christmas season offers a fine opportunity for model-builders to indulge in the lighter kinds of Meccano construction by using their Outfits to make all kinds of mechanical toys and puzzles. Several simple examples of models of this type are described in this article, and these will be found splendid for amusing one's younger brothers and sisters and friends at the Christmas party. All the models dealt with are easy to build, and their constructional details are shown in the accompanying illustrations. Three of them, the walking kangaroo, the "Cum-Bak" and a string puzzle, shown in Figs. 3, 4 and 6 respectively, were described in the Magazine several years ago, but are so interesting that they are repeated for the benefit of present-day Meccano enthusiasts.

The first model, shown in Fig. 1, is a novel toy that was designed by M. LaPipparo, Milan. It is a small "monkey" that can be made to climb vigorously up a piece of cord. The body of the monkey consists of two 3½" Strips joined by Double Brackets at 1 and 2. The bolts that fix the Double Bracket 1 in position hold also the monkey's arms, and the lower Double Bracket is held in position by the 1" Screwed Rod 3. The nuts are left sufficiently loose on the Rod to allow the legs to pivot freely. The legs are made from 2" Strips, with feet consisting of Flat Brackets, and they are connected at 4 by a 1" Screwed Rod lock-nutted in position. The ends of the Spring 5 are looped over the Screwed Rods 3 and 4, and the ¾" Bolt 6 passes through the loop so formed. Two ¾" Bolts are pushed through the Flat Brackets forming the feet and are fitted in place by lock-nuts, one of the Bolts carrying six Washers, which serve as a guide to centralise the cord.

The back of the body is a 3" Strip, which supports a Cranked Bent Strip. The ½" Bolt 7 carries a 1" loose Pulley around which a Spring is looped, the ends of the Spring being anchored on the ¾" Bolt 8.

The monkey is completed by joining the ends of the arms with a Double Bracket and fitting the head in position. A piece of Meccano Cord is now threaded through the last-mentioned Double Bracket, then around the rearmost ¾" Bolt connecting the feet, and up over the second ¾" Bolt. The Cord is fitted at each end with a 1" Pulley.

To make the monkey climb, the cord is pulled taut, thus causing the legs to straighten and move the body upward and

forward. As it does so the Cord is gripped between the coils of the upper Spring. On releasing the tension of the Cord the legs move up under the influence of the lower Spring, and are ready for the next movement.

Parts required to build the Climbing Monkey: 2 of No. 3; 1 of No. 4; 4 of No. 6; 3 of No. 10; 4 of No. 11; 2 of No. 22; 1 of No. 22a; 1 of No. 23; 27 of No. 37a; 10 of No. 37b; 8 of No. 38; 1 of No. 40; 2 of No. 43; 1 of No. 44; 2 of No. 82; 2 of No. 90; 3 of No. 111; 1 of No. 111a; 1 of No. 111c.

An ingenious puzzle always provides much good fun, and one made entirely from Meccano parts should be particularly popular. Such a puzzle is shown in Fig. 6. It is simple to make, but the problem it provides, which is to remove the Strip 2 from the frame, is by no means easy to solve! Cutting the string or undoing the knot is not allowed.

The loop of string 1 attached to the end of the 5½" Strip 2 should be of such a length as to reach half way along the Strip 2. To assemble the puzzle, first pass the loop over the points 3, 4 and 5, and then slip it down to the Trunnion 6. Next pass the loop successively over 5, 4 and 3. The loop 1 and Strip 2 are now attached to the frame as shown in the illustration.

A friend should be asked to remove the Strip 2 from the frame. It looks impossible, and he will undoubtedly find the task difficult.

Parts required to make the Puzzle: 3 of No. 2; 9 of No. 37; 4 of No. 90; 1 of No. 126a.

Fig. 4 shows a very interesting Meccano novelty that never fails to mystify anyone "not in the know." We have called it the "Cum-Bak" and it takes the form of a small drum built up from Meccano parts and is most effective when enclosed in a strip of thin cardboard. If the drum is rolled along a table or smooth floor it will

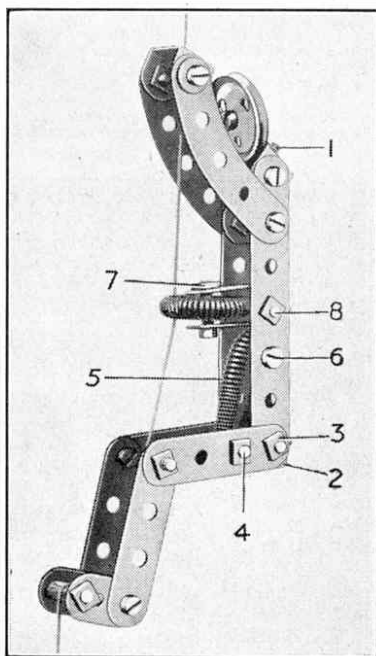

Fig. 1. A Meccano monkey that climbs up a rope.

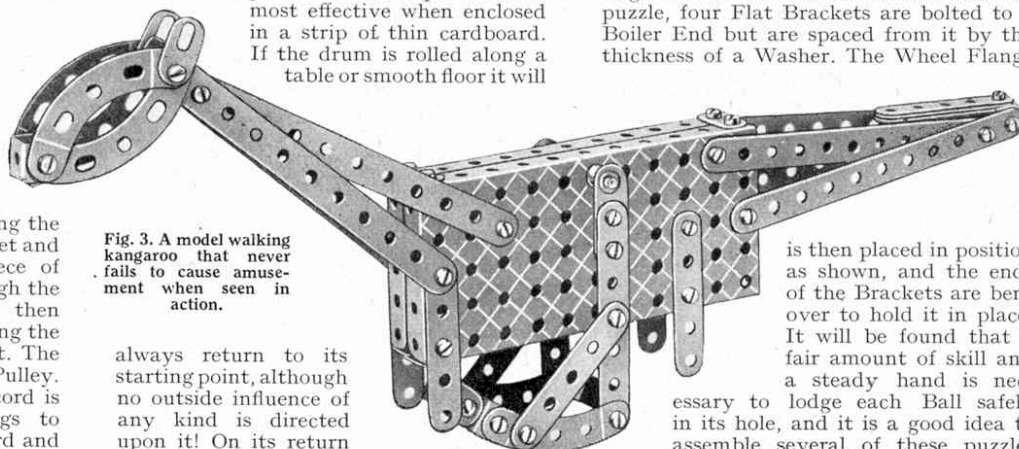

Fig. 3. A model walking kangaroo that never fails to cause amusement when seen in action.

always return to its starting point, although no outside influence of any kind is directed upon it! On its return

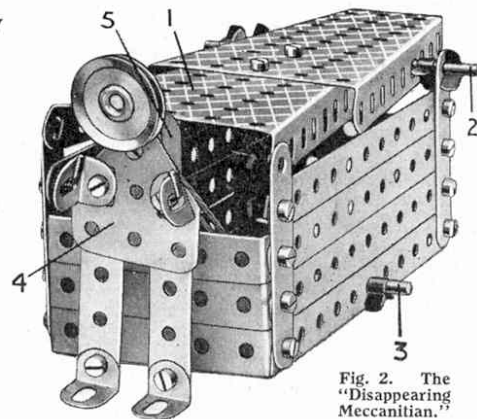

Fig. 2. The "Disappearing Meccanitian."

journey it will sometimes overstep its commencing mark, but after a few oscillatory movements it will finally come to rest practically on the spot from which it started. It will only work on a smooth surface.

The mysterious antics of the "Cum-Bak" depend entirely upon a short length of elastic and a suspended weight. The elastic is doubled and secured between the 3" Pulley Wheels, from centre to centre, and a weight, consisting of any suitable Meccano parts, is attached to it in the middle of the drum. The weight illustrated consists of a 1" loose Pulley and two 1" fast Pulleys mounted on a 1" Rod gripped in the bosses of the fast Pulleys.

As the drum rolls along the weight tends to remain in its original position and the elastic therefore becomes twisted. The resistance in the elastic retards the drum to an increasing extent and finally stops it. The effort of the elastic to return to its former state then causes the drum to roll in the opposite direction. By the time the elastic has regained its normal position the drum has gathered a certain momentum, which usually carries it a little way past its starting point. It soon returns, however, and after a few short rocking movements finally comes to rest practically at the spot from which it started its journey.

Parts required to build the model "Cum-Bak": 1 of No. 18b; 2 of No. 19b; 1 of No. 20; 10 of No. 37a; 14 of No. 37b; 4 of No. 48b; 5 of No. 59; 1 of No. 186a.

Another simple Meccano puzzle is shown in Fig. 5. It consists of a Wheel Flange in which are placed four Steel Balls, and the object is to get all the Balls in the four small holes in the Wheel Flange without allowing any of them to drop through the large hole in the centre. To assemble the puzzle, four Flat Brackets are bolted to a Boiler End but are spaced from it by the thickness of a Washer. The Wheel Flange

is then placed in position as shown, and the ends of the Brackets are bent over to hold it in place. It will be found that a fair amount of skill and a steady hand is necessary to lodge each Ball safely in its hole, and it is a good idea to assemble several of these puzzles



and pass them around a group of friends. Much amusement will be caused by each one's effort to do the trick first.

Parts required to build the Ball Puzzle: 4 of No. 10; 4 of No. 37a; 4 of No. 37b; 4 of No. 38; 4 of No. 117; 1 of No. 137; 1 of No. 162a.

Another old favourite with Meccano model-builders and one that never fails to cause amusement when seen in action is the "Walking Kangaroo" shown in Fig. 3. If placed on an incline the "kangaroo" will commence to "walk" with a quaint action, and will continue to do so as long as it remains on the downward slope. The secret lies in the construction of the body, and provided the model is built exactly as shown in the illustration the "animal" will perform without any hesitation.

The body of the kangaroo consists of two  $5\frac{1}{2}'' \times 2\frac{1}{2}''$  Flanged Plates connected together by four Flat Brackets, and its neck is constructed from four  $5\frac{1}{2}''$  Strips bolted to the Plates as shown. The head is composed of  $2\frac{1}{2}''$  Strips spaced at their lower ends only by a Double Bracket. Two Flat Brackets represent the ears. The tail is built up from four further  $5\frac{1}{2}''$  Strips joined at their outer ends by a Double Bracket. The positions of the various strips in relation to the body should be reproduced

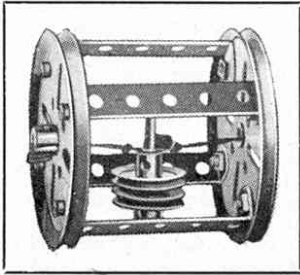

Fig. 4. The Meccano "Cum-Bak."

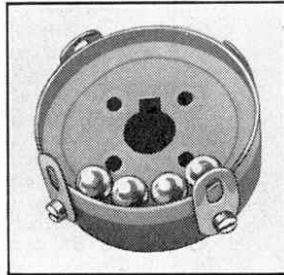

Fig. 5. An interesting Meccano puzzle.

as accurately as possible, for the successful working of the model depends upon them.

The body of the animal rocks about a short Rod secured between the rocker frame, which does duty as "legs." This frame consists of two  $3\frac{1}{2}''$  Strips bolted at their upper ends to Cranks in which the short Rod is secured and at their lower ends to two  $2\frac{1}{2}''$  large radius Curved Strips. These Curved Strips are connected together at their ends by  $1\frac{1}{2}''$  Strips bolted to Angle Brackets, and they are braced to the  $3\frac{1}{2}''$  Strips by a pair of  $2\frac{1}{2}''$  Strips.

Two pairs of  $2\frac{1}{2}''$  Strips bolted to the Flanged Plates form stops to limit the movement of the body. When placed on a slope the "kangaroo" swings forward between the Strips and tilts on its front "legs," thereby allowing the rocker frame to swing directly under the model again, when the action is repeated.

Parts required to build the Walking Kangaroo: 8 of No. 2; 2 of No. 3; 11 of No. 5; 2 of No. 6a; 8 of No. 10; 2 of No. 11; 4 of No. 12; 42 of No. 37; 2 of No. 52; 2 of No. 62; 2 of No. 90.

All readers will be familiar with the "Jack-in-the-Box" toy, and an easily built Meccano version of this is shown in Fig. 2. The bottom of the box-like portion of this model consists of a  $5\frac{1}{2}'' \times 2\frac{1}{2}''$  Flanged Plate, and three  $5\frac{1}{2}''$  Strips bolted to upright  $2\frac{1}{2}''$  Strips form each side, with three  $2\frac{1}{2}'' \times \frac{1}{2}''$  Double Angle Strips for the ends. The lid, which is mounted pivotally on an Axle Rod 2, consists of two Sector Plates bolted together, Elastic bands are tied to the sides of these Plates, and are then connected to a Rod 3 passed through the bottom of the box. The Meccanition also is connected to this Rod by pieces of

elastic. When the end of the rear Sector Plate is depressed the lid opens sufficiently to allow the figure to be drawn inside, and then snaps back into place. A Cranked Bent Strip is bolted at the back of the figure and rests against the edge of the Sector Plate.

Parts required to build the model Disappearing Meccanition: 8 of No. 2; 7 of No. 5; 1 of No. 10; 4 of No. 12; 2 of No. 16; 1 of No. 22a; 24 of No. 37a; 24 of No. 37b; 1 of No. 44; 6 of No. 48a; 2 of No. 54a; 1 of No. 126a.

Our next model, which is shown in Fig. 7, is of a rather different type, as it incorporates a Magic Motor by means of which it is set in motion. It comprises a boxer and a punching bag, and when in action the boxer belabours the bag with surprising vigour!

It is best to commence construction with the figure of the boxer. His body consists of two Flat Trunnions bolted together, the lower bolt 1 holding also an Angle Bracket. His legs are formed by a  $2\frac{1}{2}''$  Strip and a  $2\frac{1}{2}'' \times \frac{1}{2}''$  Double Angle Strip, which are pivotally attached by lock-nutted bolts to Angle Brackets fixed to the Trunnions. One of his arms is a  $2\frac{1}{2}'' \times \frac{1}{2}''$  Double Angle Strip and the other is a  $2\frac{1}{2}''$  Curved Strip. A 1" Pulley fixed to a Flat Bracket forms his head. The figure is fixed to the  $5\frac{1}{2}'' \times 2\frac{1}{2}''$  Flanged Plate that forms the base. The Trunnions 2 provide bearings for a 2" Rod that carries a Bush Wheel and a 1" Pulley. A  $2\frac{1}{2}''$  Curved Strip 3 is pivoted by lock-nutted bolts to the Bush Wheel and the  $2\frac{1}{2}''$  Strip 4, which is bolted to the Angle Bracket at the back of the boxer.

The Magic Motor is bolted to the Flanged Plate as shown, and a small Driving Band connects its driving pulley to the 1" Pulley.

The punching bag can be made either from a piece of cloth filled with sawdust, or from a Meccano Loaded Sack (Part No. 122), and is supported by wire from a  $2\frac{1}{2}''$  Strip, which is attached by an Angle Bracket to the  $5\frac{1}{2}'' \times 1\frac{1}{2}''$  Flexible Plate 5. The latter is reinforced by a vertical  $5\frac{1}{2}''$  Strip. The bottom of the sack is connected to the Flanged Plate by a length of elastic.

Parts required to build the model Boxer: 1 of No. 2; 4 of No. 5; 1 of No. 10; 7 of No. 12; 1 of No. 17; 2 of No. 22; 1 of No. 24; 29 of No. 37a; 24 of No. 37b; 2 of No. 38; 2 of No. 48a; 1 of No. 52; 2 of No. 90a; 2 of No. 111c; 2 of No. 126; 2 of No. 126a; 2 of No. 189; 1 Magic Motor.

Readers who possess a No. 1, No. 1a or a No. 2 Clockwork Motor can use it as the main feature of an amusing toy horse on wheels. The Motor forms the body of the horse, and to the lower corners of its sideplates the legs and neck are bolted. These are represented by  $2\frac{1}{2}''$  Strips, and the front legs are connected by Angle Brackets that carry a  $2\frac{1}{2}'' \times \frac{1}{2}''$  Double Angle Strip, through which passes a  $3\frac{1}{2}''$  Rod

fitted with a 1" Pulley at each end.

A single 1" Pulley forming the rear

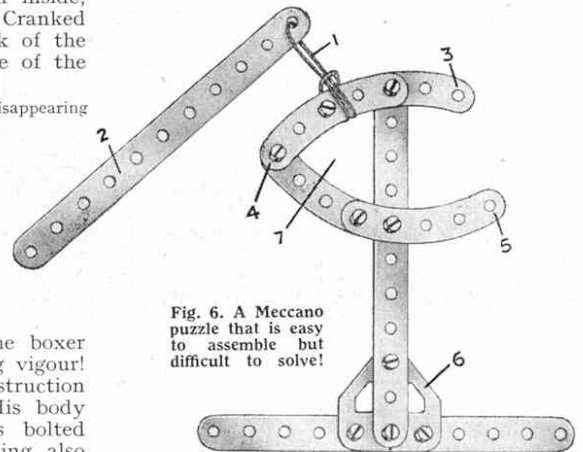

Fig. 6. A Meccano puzzle that is easy to assemble but difficult to solve!

wheel is carried on a 2" Axle Rod passed through the lower end holes of the  $2\frac{1}{2}''$  Strips. The Pulley is driven from a similar Pulley on the motor driving shaft.

A Trunnion forms the horse's head and is provided with two Flat Brackets for ears. A  $2\frac{1}{2}''$  Curved Strip bolted to the brake lever of the Motor forms the animal's tail.

Parts required: 6 of No. 5; 2 of No. 10; 3 of No. 12; 1 of No. 16; 1 of No. 17; 4 of No. 22; 2 of No. 35; 14 of No. 37; 1 of No. 40; 1 of No. 48a; 1 of No. 90a; 2 of No. 126; 1 No. 1 Clockwork Motor.

Another Meccano toy animal that will amuse the younger people at a party is a "Bucking Broncho." This consists of two  $5\frac{1}{2}''$  Strips pivotally connected edge to edge by means of a Flat Bracket and bolted through two holes in one end of a  $2\frac{1}{2}''$  Curved Strip. This Strip is bolted at its upper end to a  $2\frac{1}{2}''$  Strip representing the animal's neck. The horse's body is a  $2\frac{1}{2}''$  Strip, and the hind legs are  $2\frac{1}{2}''$  Strips joined to the body by a lock-nutted bolt.

The rider consists of a Flat Trunnion and a  $2\frac{1}{2}''$  Strip. Two further  $2\frac{1}{2}''$  Strips form his legs and two  $2\frac{1}{2}''$  Curved Strips his arms, which are lock-nutted to his body and to the horse's neck respectively. By moving the two  $5\frac{1}{2}''$  Strips the horse can be made to perform all sorts of tricks.

Parts required to build this model are: 2 of No. 2; 6 of No. 5; 2 of No. 10; 1 of No. 23; 1 of No. 37; 9 of No. 37a; 4 of No. 90a; 1 of No. 111c; 1 of No. 126a.

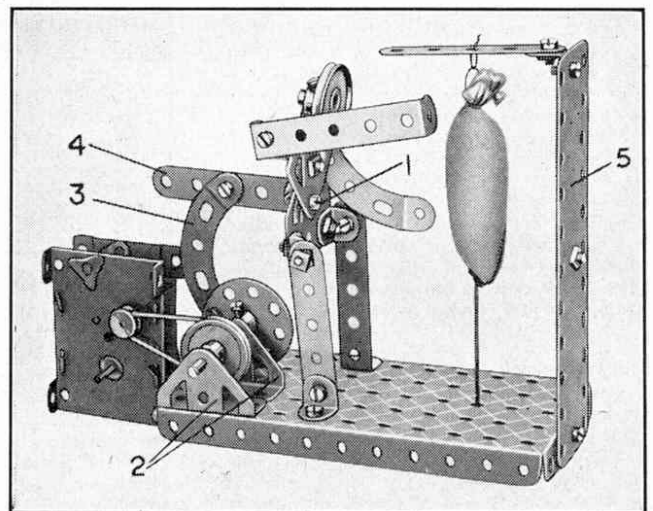

Fig. 7. An amusing model of a boxer in action with a punching bag. It is operated by a "Magic" Motor.