

Meccano Suggestions Section

By "Spanner"

(399) Spur Gear Differential (Professor D. R. Hartree, Manchester)

Various kinds of Meccano differentials built up from Bevel Gears, or with Contrate Wheels and Pinions, have been described from time to time in "Suggestions Section." This month we illustrate and describe a further type that is made entirely with spur gears. Units of this kind are used in real engineering when very heavy loads have to be dealt with, and in view of the ease with which such a differential can be assembled many model-builders no doubt will like to experiment with this type as a change from the more usual varieties.

The compact example shown in Fig. 399 was designed by Professor D. R. Hartree, Manchester, who built the Meccano differential analyser illustrated and described in the "M.M." for June 1934. It is shown here as it would be fitted for use in

a model motor vehicle, the drive being taken through a $1\frac{1}{2}$ " Helical Gear fastened to the cage by means of a Socket Coupling.

The cage in which the mechanism is contained consists of two Face Plates joined by two $1\frac{1}{2}$ " \times $\frac{1}{2}$ " Double Angle Strips, one end of each Double Angle Strip being spaced from the Face Plate by a Washer. Rod 1 is pushed through the boss of the left-hand Face Plate and carries two Washers, a 1" Gear, a Collar 4 and another Washer. Rod 2 carries two Washers and a 1" Gear, and the latter is so arranged on the Rod that Rod 1 protrudes about $\frac{1}{4}$ " into its boss, thus making the axle assembly more rigid.

The $\frac{1}{2}$ " \times $\frac{1}{2}$ " Pinions 5 and 6, and a similar pair of Pinions diametrically opposite to them, are fastened on 1" Rods, using the new short Grub Screws (Part No. 69c). The Pinions are then engaged in the manner shown and Couplings 3 are fitted on the 1" Rods. The Pinions and Couplings are then placed in the differential cage and held in place by $\frac{3}{8}$ " Bolts, which pass through the slotted holes in the Face Plate so as to permit the Pinions to mesh properly with the 1" Gears. Pinion 5 meshes with the left-hand 1" Gear only and Pinion 6 meshes with the right-hand Gear. It is important that diametrically opposite Pinions are arranged to mesh with the same Gear.

If desired the casing can be completed by bolting two $5\frac{1}{2}$ " \times $1\frac{1}{2}$ " Flexible Plates, or further $1\frac{1}{2}$ " \times $\frac{1}{2}$ " Double Angle Strips, around the Face Plates. To transmit the drive to the cage, a $1\frac{1}{2}$ " Helical Gear is gripped in a Socket Coupling and the latter is fastened to the boss of the right-hand Face Plate.

When the cage is rotated, the drive is transmitted to the Rods 1 and 2 by the Pinions, which do not rotate. If the Wheel or Rod 1 is held firmly, however, Pinions 5 immediately ride around the 1" Gear. Their movement is transmitted through Pinions 6 to the other 1" Gear, thus turning Rod 2. A similar procedure takes place when the other wheel or Rod 2 is gripped.

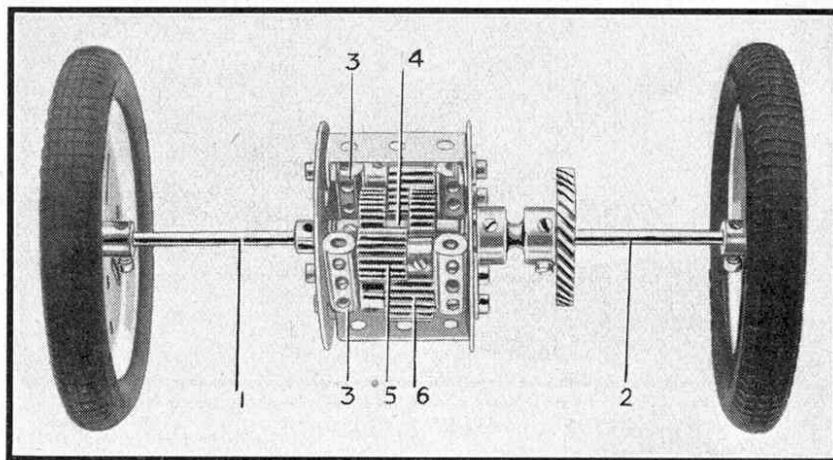

Fig. 399

(400) A Neat Roller Bearing Unit

(W. McColl, Winchester, and R. Purton, Boreham Wood)

In building model cranes, mechanical excavators and similar engineering structures in which heavy rotating superstructures are required, it is advisable to incorporate some kind of roller bearing. There are several different kinds of suitable bearings, each of which can easily be made up with Meccano parts, and some of these have already been described in "Suggestions Section." Another type is shown in Fig. 400. This was designed by W. McColl, Winchester, and makes use of the Flanged Disc that forms part of the Ball Bearing (Part No. 168). A useful feature of this unit is that the drive to the superstructure is inside the cab, thus eliminating the exterior driving shaft and pinion necessary with most other types.

The lower Flanged Disc 1 is mounted on the platform of the model, beneath which is bolted a Double Arm Crank so that its boss, in which is a 2" Rod 3, coincides with the centre of the Disc. The eight rollers 2 are $\frac{3}{4}$ " Flanged Wheels, each of which is free to rotate on a Pivot Bolt that is lock-nutted to an Angle Bracket bolted to a Face Plate. The Face Plate is placed on Rod 3 followed by a second Flanged Disc, which is bolted to the underside of the superstructure to be rotated.

Rotation of the superstructure is carried out as follows. A 57-teeth Gear 4 is fastened on Rod 3 and is arranged to mesh with a Worm. When the Bush Wheel is rotated the Worm pulls itself and the superstructure around the 57-teeth Gear.

R. Purton's suggestion concerns a different type of unit, which is similar in certain respects to one suggested by Alister Inlay, Skene, which was described in the December 1937 "M.M." The unit is compact and easily assembled, and is particularly suitable for use in small models. In making it a $1\frac{1}{2}$ " Pulley and a $2\frac{1}{2}$ " Gear are bolted inside and outside a Wheel Flange respectively. Steel Balls are arranged in the Wheel Flange and above them is placed a 2" Sprocket Wheel. Reversed Angle Brackets are bolted to the latter, and they in turn carry a $3\frac{1}{2}$ " \times $2\frac{1}{2}$ " Flanged Plate. This unit is then fitted on the 2" Rod already mentioned, and is retained in position by a

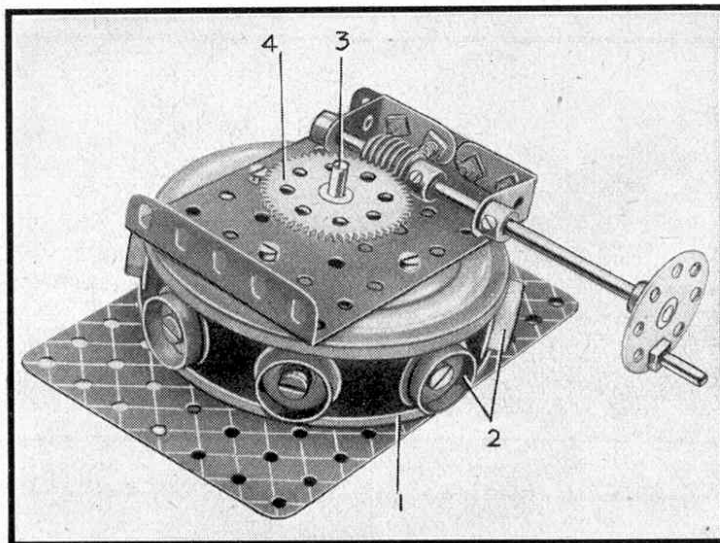

Fig. 400

Collar. The superstructure, which can be built up on the Flanged Plate, is rotated by a $\frac{1}{2}$ " Pinion on a vertical Rod journaled in the Plate, the Pinion meshing with the $2\frac{1}{2}$ " Gear bolted to the Wheel Flange.

In order to mount the unit on a base the $2\frac{1}{2}$ " Gear is bolted to a $5\frac{1}{2}$ " \times $2\frac{1}{2}$ " Flanged Plate, and spaced from it by Washers and Collars. Alternatively, the Gear can be spaced by Washers from a 4" Circular Plate mounted in a frame of Angle Girders. The spacing Washers permit the Pinion to mesh with the $2\frac{1}{2}$ " Gear.

If desired the superstructure can be rotated by Sprocket drive.

(401) Trailer Steering Gear

(B. Farrar, Dagenham)

An important problem in the design of trailer vehicles is the provision of efficient steering mechanism. In the simplest type of gear the front axle is pivoted at its centre and is connected by a draw-bar to the rear of the hauling vehicle. As the trailer tends to turn in a smaller arc than the hauling vehicle this system is suitable only for small and light trailers. If it is used for a large and heavily loaded vehicle the work of steering is fatiguing for the driver.

A steering system suitable for a heavy trailer forms the subject of a suggestion submitted by B. Farrar, Dagenham. In this the wheels are mounted on stub axles, and the arrangement is such that the inner wheel is turned at a sharper angle than the outermost wheel. An advantage of this system is that the wheel track is the same when the trailer is turning as when the two vehicles are travelling in a straight path.

The stub axles for the road wheels are mounted on two $2\frac{1}{2}$ " Rods 2, which are connected by Couplings to a $6\frac{1}{2}$ " Rod 1. On this Rod are mounted two Cranks and a Collar, and the Cranks are connected by Springs to the chassis of the trailer to provide a suspension system. A Swivel Bearing 3 is fixed on the end of each Rod 2, and in the "spider" of each Swivel Bearing is fastened a $1\frac{1}{2}$ " Rod that forms the stub axle for the wheel. One of the set-screws is removed from each Swivel Bearing and is replaced by a $\frac{3}{8}$ " Bolt 4, against the head of which is locked a $1\frac{1}{2}$ " Strip.

A Boss Bell Crank 6, carried on a Pivot Bolt screwed into the Collar on Rod 6, is locked in place with a nut. The trailer draw-bar 7 is a Cranked Bent Strip, which is attached to the boss of the Boss Bell Crank by a bolt that carries a nut and washer for spacing purposes. The Bell Crank and the $1\frac{1}{2}$ " Strips are linked by $5\frac{1}{2}$ " Strips, each of which is carried on lock-nutted bolts. The wheels are 2" Pulleys, and are spaced from the Swivel Bearings by Spring Clips and Washers.

When the draw-bar 7 is connected to the hauling vehicle the tension on the draw-bar maintains the wheels parallel. When the draw-bar is pulled to one side as the vehicle turns the links transmit the movement to the $1\frac{1}{2}$ " Strips, thus causing the trailer to follow the same path as that traversed by the hauling vehicle.

Although the mechanism shown in Fig. 401 is assembled in conjunction with a torsion spring arrangement, it is not absolutely necessary to adhere to this type of springing, as the steering gear works well with semi-elliptic springs. Springs of this type were described in "Suggestions Section" for February 1937, and are more suitable for a model that carries heavy loads. Strong torsion springs were described in the December 1936 "M.M."

(402) Model Aeroplane Winder

(H. Wright, Sedbergh)

The device shown in Fig. 402 was designed by H. Wright for winding up the elastic motors in his small model aeroplanes. The gearing used in the device gives 10 revo-

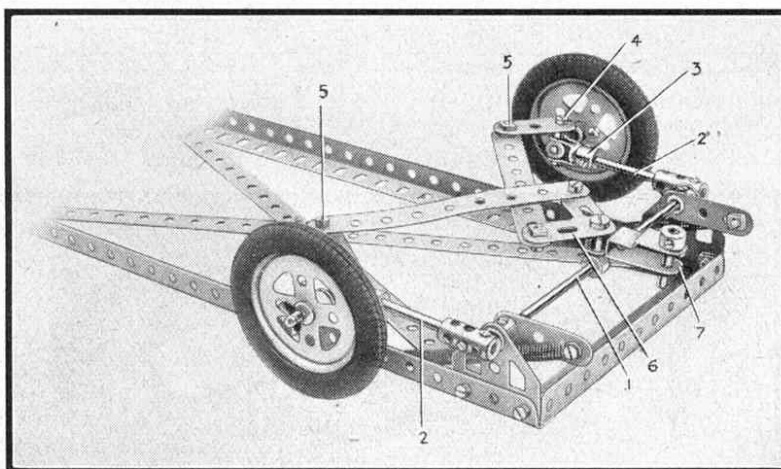

Fig. 401

lutions of the hook to one revolution of the handle, and enables the elastic to be "wound" in a very short time.

The gearing is contained in a frame made from two $3\frac{1}{2}$ " x $2\frac{1}{2}$ " Flanged Plates joined by two $2\frac{1}{2}$ " x $2\frac{1}{2}$ " Flat Plates. A handle for holding the winder is made from a Wood Roller mounted on a 5" Screwed Rod. A 5" Rod prevents the Roller from rotating.

Rod 1 is $3\frac{1}{2}$ " long, and carries a $1\frac{1}{2}$ " Helical Gear and a Ratchet Wheel 2 in addition to the handle. At right angles to

Miscellaneous Suggestions

Under this heading "Spanner" replies to readers who submit interesting suggestions regarding new Meccano models or movements that he is unable to deal with more fully elsewhere. On occasion he offers comments and technical criticisms that, he trusts, will be accepted in the same spirit of mutual help in which they are advanced.

(M.200.) P. LeFevre, Harleston, Norfolk, submitted details of a novel device that he suggests could be used as an electric tooth cleaner. The device is not really suitable for this purpose, but I am describing it here because it incorporates a rapid reciprocating movement that is adaptable for use in a variety of other mechanisms.

The mechanism is contained in a Boiler, in one End of which is a Magnet Coil, complete with Core. Opposite this, and protruding through the other End of the Boiler, is an $11\frac{1}{2}$ " Rod fitted with a Collar. A Double Arm Crank is fastened to the Rod so that it makes contact with an insulated 6 B.A. Bolt, which

is connected to one terminal of a battery. The Crank is connected to one of the terminals of the Magnet Coil, the other terminal of which is connected to the remaining free terminal of the battery. A small spring normally holds the Double Arm Crank in contact with the 6 B.A. Bolt, but when the current is switched on the $11\frac{1}{2}$ " Rod is drawn towards the Magnet Coil. This movement breaks the electric circuit, which is completed again when the $11\frac{1}{2}$ " Rod slides back under the influence of the spring. If the distance between the Collar and the Magnet Coil and the tension of the spring is carefully adjusted, very rapid movement can be obtained.

I shall be interested to hear of any uses to which this or a similar mechanism is put.

(M.201.) It is not often that spoked rubber-tyred wheels are required in model-building, but when P. Kemp, Market Drayton, needed such parts for a model gun carriage he was able to build up neat wheels from standard Meccano parts. He discovered that the Wheels, Part No. 19a, can be used in conjunction with the 3 in. Rubber Tyres, Part No. 142b.

One Wheel is fastened on a Rod and the Rubber Tyre is fitted against its rim. A second wheel is then pushed against the other side of the Tyre. The complete wheel is quite solid and there is no likelihood of the Tyre coming off.

Smaller wheels of this kind can be built up by using the Steering Wheels, Part No. 185, and $1\frac{1}{2}$ in. Rubber Tyres, Part No. 142d.

(M.202.) From P. Mountfort, Howera, New Zealand, comes a suggestion for a simple type of screw brake for use on small model trucks. A Coupling is mounted longitudinally on the axle of the model and a 1" Screwed Rod is partly screwed into its transverse threaded bore. The other end of the Screwed Rod carries a Collar by which it is screwed into contact with the axle.

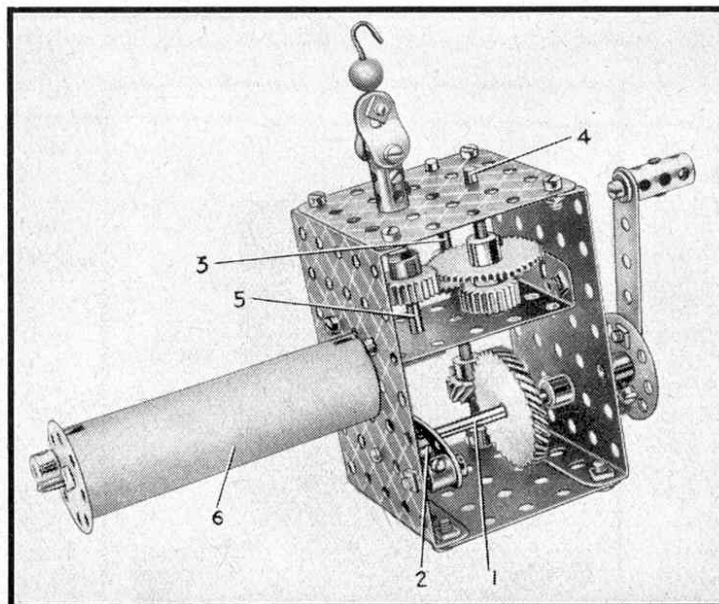

Fig. 402

this Rod is a 4" Rod 3, which passes below the $2\frac{1}{2}$ " x $1\frac{1}{2}$ " Flanged Plate inside the frame. Rod 3 carries a $\frac{1}{2}$ " Helical Gear and a 50-teeth Gear, and is held in place by two Collars. The 50-teeth Gear meshes with a $\frac{3}{4}$ " Pinion on Rod 4, which carries also a second 50-teeth Gear that engages the $\frac{3}{4}$ " Pinion on $2\frac{1}{2}$ " Rod 5. It is advisable to use double Grub Screws in all the Gears and Pinions in order to fix them securely on their Rods.