

Meccano Suggestions Section

By "Spanner"

(370) Remote Control (R. Jameson, Coventry)

Many model-builders wish that they could control the various movements of their model cranes from a distance, thus adding realism to the model. R. Jameson, Coventry, recently submitted a suggestion in which Elektron Magnet Coils are used to move the various levers. Current is passed through the appropriate coil by means of a distant switch and the corresponding lever is then moved as if it were pulled by hand.

Magnet Coils have the advantage that they can be placed in almost any suitable position in a model. Two levers are shown in Fig. 370, illustrating this suggestion. The Magnet Coils are suitably mounted behind the levers, and in this instance they are clamped between two $3\frac{1}{2} \times \frac{1}{2}$ " Double Angle Strips 1 by means of 1" Screwed Rods. The 2" Rods 2 rest in the Magnet Coils and are fitted with Small Fork Pieces 3, and attached to the levers by means of Collars.

The switch consists of $2\frac{1}{2}$ " Strips and 4" Curved Strips, spaced by two Collars at the top, and by Washers and locknuts at the bottom. By this means the switch arm 5, fitted with Washers 6, is held clear of the 4" Curved Strips. Two insulated terminals 7 are mounted on one of the Curved Strips, and there are two further terminals 8 and 9 on the base. Of these terminals only 8 is insulated.

The wiring is simple. The inner terminals of the Magnet Coils, that is those nearer the openings in the centres of the Coils, are joined together and connected to the insulated terminal 8, and the outer terminals are connected separately to the insulated terminals 7. Current is supplied through the terminals 8 and 9. When the switch is moved to one side to make contact with one of the terminals 7, the circuit of one of the Magnet Coils is completed through the base, and the corresponding lever is pulled. The second lever is operated by moving the switch to the opposite side, and springs return each lever when current in the corresponding Magnet Coil is switched off.

(371) Free-Wheel

(R. Tiystra, Holland)

A novel friction wheel that can be used in models in which the drive is to be transmitted only in one direction has been submitted by R. Tiystra, Holland. This is shown in Fig. 371.

The mechanism is constructed by fitting a Double Arm Crank to a Boiler End by means of the bolts 1, and mounting this on the Rod forming the driving shaft. The inner edge of the Boiler End forms the friction surface. Flat Brackets are pivotally attached to a Bush Wheel also on the driving shaft, and are lock-nutted by the nut 2. The bolts 3, spaced by two Washers, fasten Angle Brackets on the outer ends of the Flat Brackets. These Angle Brackets serve as brake shoes, and a Collar 4 keeps an elastic band 5 in tension, so that they are held in contact with the Boiler End. Rubber bands are wrapped round the contact surface of the Angle Brackets in order to provide a better grip.

When the shaft rotates in one direction it carries the Boiler End with it. On reversing the direction, the Boiler End remains still.

(372) A Useful Hand Fret-Saw (H. Howes, Stoke)

One of the many practical ways in which Meccano parts may be used is in making tools for the home workshop. Several useful tools that can be easily and quickly assembled have already been described and illustrated in the "Suggestions Section" pages of the

"M.M.," and this month I am including a description of a hand fret-saw, which forms the subject of a suggestion put forward recently by H. Howes, Stoke. Howes constructed this saw some time ago and I think it will prove a useful addition to the workshop equipment of other Meccano enthusiasts. The fret-saw blade is held in a rigid and strong frame, the arms of which consist of several $12\frac{1}{2}$ " Strips bolted together face to face. The ends of the frame are composed of $2\frac{1}{2}$ " large radius Curved Strips and $3\frac{1}{2}$ " Strips, and are joined to the arms with $2\frac{1}{2}$ " Strips.

An important point in the construction of the frame is that all bolts must be tightly secured in place, as the

frame is subjected to considerable vibration when in use. The saw frame is fitted with a handle built up from four $5\frac{1}{2}$ " Angle Girders, which are bolted together by means of 1×1 " Angle Brackets so as to form a box girder. This is then attached to the frame with Strips. In order to provide a good gripping surface a length of Cord is wrapped round the handle in a manner similar to that adopted in finishing the handle of a cricket bat.

A simple screw mechanism is incorporated in the handle to control the tension of the blade. The blade is held at each end in Couplings, the lower one of which is attached to the screw tension mechanism, while the upper one is held by $2\frac{1}{2}$ " Strips to the frame. The screw tension mechanism consists of a Screwed Rod fixed at one end in the Coupling that carries the blade. The other end passes through the boss of a $1\frac{1}{2}$ " Pulley, and is fitted with a butterfly nut composed of two Centre Forks held in a Coupling.

(373) A Simple Gearless Differential (A. Shand, Glasgow)

Most differentials built up from Meccano for use in models such as motor vehicles require the use of gears. When A. Shand of Glasgow wished to construct such a mechanism for one of his models and had insufficient gears for the purpose, however, he set to work to devise some other form of differential. He succeeded in producing the following simple device, which can be made up without

the use of any gears whatever in the differential proper.

Two $\frac{1}{2}$ " loose Pulleys are fitted with Dinky Toys Rubber Tyres and mounted on Pivot Bolts fitted with Compression Springs. The Pivot Bolts are then screwed into the centre tapped holes of a Coupling, and serve to lock in position a $1\frac{1}{2}$ " Rod that is journaled in the plain hole of the Coupling. Two $\frac{1}{2}$ " fixed Pulleys mounted on the back axles are also fitted with Dinky Toys Rubber Tyres, and are arranged to coincide with the Rubber Rings on the $\frac{1}{2}$ " loose Pulleys.

Collars fitted with 1" Screwed Rods are fastened to the $1\frac{1}{2}$ " Rod in the Coupling and their remote ends are securely lock-nutted to a $1\frac{1}{2}$ " Contrate Wheel, which also is fastened to the back axle.

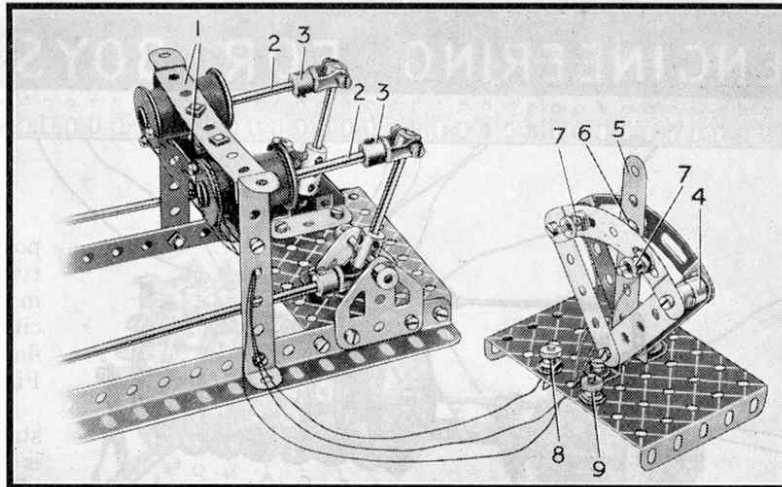

Fig. 370

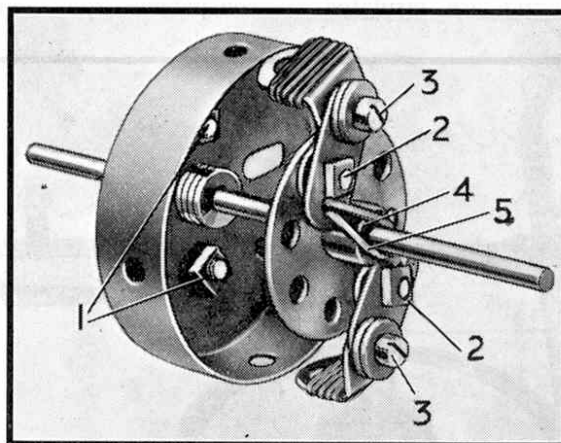

Fig. 371

(374) Front Wheel Springing

(T. Holmes, Plymouth, and J. Smith, Bristol)

The large number of suggestions for novel mechanisms and refinements for motor car chassis models is striking evidence of the popularity of this type of model. Methods of springing attract many model-builders, and two types of rear wheel springing were described in these pages in the Magazine for December 1936. Several ingenious suggestions for both front and rear wheel springing have since been submitted, and two of these, both for front wheels, are illustrated on this page.

The first of these suggestions was submitted by T. Holmes, Plymouth, and is suitable for use in the Meccano Super Model Motor Chassis or in any large chassis where a robust type of springing is desirable. An underneath view of his device is shown in Fig. 374a. Semi-elliptic springs of the type used in the Meccano Motor Chassis are fitted with Couplings 1, and 2" Screwed Rods 2 are passed through the tapped holes into other Couplings 3 and 4, where they lock in position the 1/2" bolts 4, which are held in Collars by means of Grub Screws and 4 1/2" Screwed Rods. Two more Couplings are then fitted as before with 4 1/2" Screwed Rods, and are fastened to the Couplings 4 by means of a 3/4" Bolt, and spaced by a Washer.

The steering mechanism is then fitted. This consists of a Collar 6, fastened to a 1" Rod and fitted with a 3" Pulley mounted on a 1/2" bolt. The 1" Rod is pushed through the Coupling 3, and Cranks connected by the track rod 7 are secured in place.

The second suggestion of this kind is an independent springing suspension suitable for a front-wheel drive, and was submitted by J. Smith, Bristol. It is shown in part in Fig. 374. The differential and nearside suspension have been omitted for the sake of clearness.

Two 5 1/2" Angle Girders bolted across the chassis form the supports for 1" Triangular Plates 1, and the method of mounting the Hexagonal Couplings 2 can be seen from the illustration. Four 1 1/2" Strips 3 are pivoted at the outer corners of the Triangular Plate 1 by means of the 1 1/2" Rod 4, and the 8" Screwed Rod 5, which acts as a torsion rod. The Couplings 6 and 7 are fastened securely to the Screwed Rod 5 by means of Grub Screws, the Coupling 6 being tightly lock-nutted to the 1 1/2" Strips.

The Collar 8 is then pivotally mounted between the 1 1/2" Strips, and the arrangement is duplicated between the lower 1 1/2" Strips. A Socket Coupling 9, pivotally attached by 1/2" bolts lock-nutted between the two Collars, forms a bearing for a 3" Pulley secured to the end of the Flexible Coupling 10. The usual steering mechanism is then fitted to the Socket Coupling 9 by means of a bolt spaced by Washers.

It should be noted that small Grub Screws should be used for securing the 3" Pulley to Coupling 10 so that it is able to rotate freely in the Socket Coupling, which should swivel between the Collars.

(375) Double Reciprocating Motion

(L. Edwards, Auckland, N.Z.)

From L. Edwards, North Auckland, New Zealand, comes a suggestion for a novel type of double reciprocating motion that can be adjusted to give strokes of different lengths,

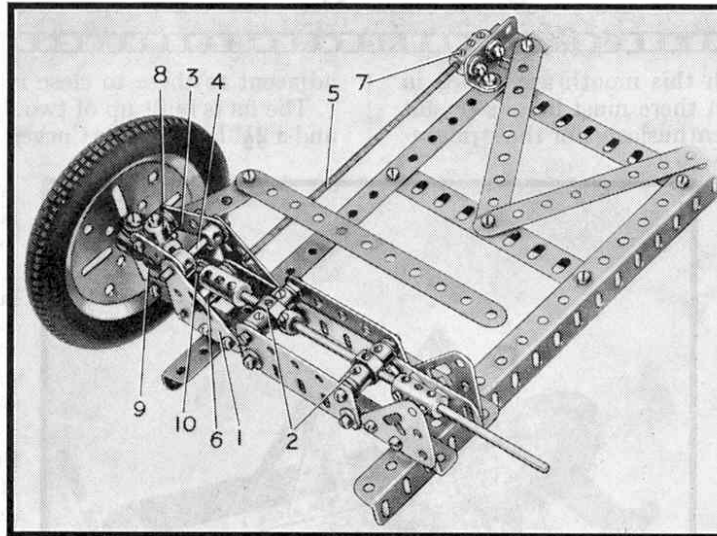

Fig. 374

in a manner unobtainable with Eccentrics. Edwards used the device to drive a pump direct from the connecting rod of a steam engine.

A 3" Pulley is fastened on a Rod that is journalled in 2 1/2" Strips bolted to a framework consisting of Angle Girders and two 3 1/2" x 2 1/2" Flanged Plates. A 6 1/2" Rod, fixed at one end in a Handrail Support that is pivotally attached and lock-nutted to the 3" Pulley, forms the connecting rod. This is then connected to the conventional cross-

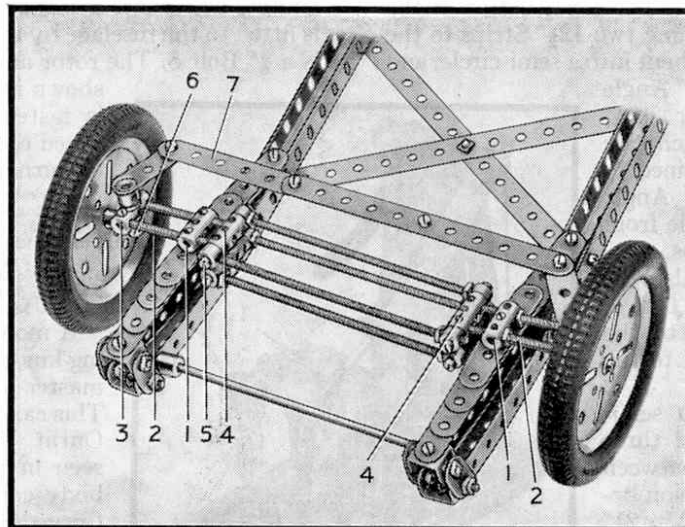

Fig. 374a

head and slide bars.

A small cylinder constructed from two 3/4" Flanged Wheels and a Sleeve Piece is mounted on a 5 1/2" x 2 1/2" Flanged Plate erected on the 12 1/2" Angle Girders, and is fitted with a connecting rod that carries a small Fork Piece. The latter is pivotally attached to a Collar, on the engine connecting rod by means of Bolts spaced by Washers.

The oscillation of the engine connecting rod actuates the small pumping cylinder through the second connecting rod.

(376) Centrifugal Speed Indicator

(Bristol Grammar School Meccano Club)

An interesting suggestion for a centrifugal speed indicator, which incorporates features that have not appeared in indicating mechanisms previously described in the "Suggestions Section," was submitted recently by members of the Bristol Grammar School Meccano Club. A rhomboid figure, that is one with four equal sides, is made to rotate by means of gears, and as the speed of rotation increases, weights consisting of Flanged Wheels attached to the rhombus tend to move outward. This movement draws a Bush Wheel and Face Plate up the spindle on which the rhombus rotates. The motion of the Face Plate is transmitted to a spindle fitted with a pointer that move over a suitably calibrated dial.

The essential mechanism consists of two rhomboid figures, the sides of which are built up from 5 1/2" Strips. These are then joined together face to face, and at the upper angle are pivotally attached to a Rod carried in a Coupling fastened to the end of an 11 1/2" Rod. Four 1 1/2" Flanged Wheels, two fixed on each side of the rhombus, are fastened to 2" Rods that are held to the 5 1/2" Strips by Collars. The lower corner of the rhombus is attached by Angle Brackets to a Bush Wheel, which in turn is fixed by means of 3/4" Bolts to a Face Plate. The Bush Wheel and Face Plate are arranged to slide on the 11 1/2" Rod.

A base consisting of 12 1/2" and 5 1/2" Angle Girders and a 5 1/2" x 2 1/2" Flanged Plate, supports a box-like structure composed of two 3 1/2" x 2 1/2" and one 5 1/2" x 2 1/2" Flanged Plates. A reinforced bearing is provided in the upper Flanged Plate for the 11 1/2" Rod, which is extended by a 4 1/2" Rod. Movement of the rhombus when the device is in motion is transmitted to an indicating arrangement consisting of a 2 3/8" x 1" Double Angle Strip, through the centre hole of which passes the 11 1/2" Rod. The Double Angle Strip is fitted with Angle Brackets that make contact with the Face Plate.

Two 4 1/2" Rods are journalled in the bosses of Cranks bolted to the 5 1/2" x 2 1/2" Flanged Plate, and are connected by Collars to the 2 3/8" x 1" Double Angle Strip. To one of the Rods the spider and fork piece from a Universal Coupling are connected. A Rod, the ends of which are journalled in a Coupling on the pointer spindle and in the Fork Piece, transmits the upward and downward movement of the Face Plate to the pointer.

A spring is not required to return the pointer, as the weight of the various parts of the mechanism is capable of doing this. The dial can be calibrated by working the apparatus from mechanisms such as a gramophone turntable rotating at known speeds, using different ratio gearing between the driving and driven shafts.