

# Meccano Suggestions Section

By "Spanner"

## (380) Pre-Selector Gear-Box

(B. Rees, Cardiff)

The illustrations on this page show a compact pre-selector gear-box, suitable for use in model motor chassis, that has been designed by B. Rees, Cardiff. It has four forward speeds and reverse, and any gear required can be selected beforehand, to be brought into operation when it is wanted by merely depressing a foot pedal.

The driven shaft 4 of this gear-box is a  $3\frac{1}{2}$ " Rod, and carries at its inner end a Coupling 5. A 57-teeth Gear and a 50-teeth Gear are placed on the Rod between the  $1\frac{1}{2}$ "  $\times$   $1\frac{1}{2}$ " Angle Bracket and the Double Angle Strip, and the  $\frac{1}{2}$ " Pinion that forms part of the reverse gear also is fastened on the Rod, but outside the frame of the gear-box. A second  $\frac{1}{2}$ " Pinion is secured to a Pivot Bolt passed through the centre hole of the right-hand  $3\frac{1}{2}$ "  $\times$   $\frac{1}{2}$ " Double Angle Strip 1, and is in constant mesh with the adjacent  $\frac{1}{2}$ " Pinion.

The driving shaft carries between the Angle Bracket and the Double Angle Strip, a Collar, a  $\frac{3}{4}$ " Pinion and a  $\frac{1}{2}$ "  $\times$   $\frac{1}{2}$ " Pinion. Between the two  $1\frac{1}{2}$ "  $\times$   $1\frac{1}{2}$ " Angle Brackets the Rod passes through the elongated hole of the Crank 7, and a built-up dog clutch is fitted to the end of the Rod. The clutch consists of a Collar 6 fixed to the Rod by two Bolts, which also pass through the elongated holes of two Flat Brackets. A second Collar is spaced from Collar 7 by half a Compression Spring, and the Flat Brackets are secured to it by two Set Screws. The layshaft is a compound rod formed by joining together a 2" Rod and a 5" Rod by a Coupling. The 2" member of the Rod carries a 50-teeth Gear, and the 5" member carries a 57-teeth Gear, Crank 7, a Collar, Crank 8, six Washers, a  $\frac{1}{2}$ " Pinion 10 and finally a  $\frac{3}{4}$ " Pinion. Outside the frame of the gear-box and on the same Rod, are three Washers and a  $\frac{1}{2}$ " Pinion. Crank 7 is free on the layshaft, and Crank 8 is held between the Collar and  $\frac{1}{2}$ " Pinion.

The gear-changing mechanism is very simple both in construction and operation. A  $6\frac{1}{2}$ " Rod is journaled in the upper holes of the  $1\frac{1}{2}$ " Corner Brackets 3, and it carries Coupling 9, a Collar, Crank 8 and a second Collar. A  $3\frac{1}{2}$ " Rack Strip 12 has two Reversed Angle Brackets 11 bolted to it, and these are secured in the threaded holes of the Collars by bolts, the securing nuts being tightened up against the Brackets to hold them in place. A Flat Bracket 13 acts as a support for the Rack Strip.

Reference to Fig. 380 will make clear the construction of the selector. A  $4\frac{1}{2}$ " Rod 14 carries a Boss Bell Crank 15, which forms the operating pedal. A 3" Strip is fastened to the horizontal arm of the Crank 15, and at its free end it carries a  $1\frac{1}{2}$ "  $\times$   $\frac{1}{2}$ " Angle Bracket arranged so that the shorter arm of the Bracket acts as a stop by making contact with the side member of the gear-box.

The gate is built up on two 2" Screwed Rods fastened one above the other to the left-hand Corner Bracket 3, and  $1\frac{1}{2}$ " Strips are placed on the Rods and spaced by Washers so that their positions coincide with those of the gears. The large Fork Piece 17 is pivoted on a 1" Rod held in the top hole of a Coupling fixed on Rod 14.

An Angle Bracket is firmly held by a Bolt and Washers so that it prevents excessive upward movement of the large Fork Piece.

The complete clutch is shown in Fig. 380, and the construction of its components can be seen in Fig. 380a.

The operation of the gear-box is as follows. The desired gear is selected by moving the gear lever, when the Compression Springs on one side of Coupling 9 are compressed. In order to change gear, the foot pedal is depressed so that the Flanged Wheel is withdrawn by the fork 18, thus bringing the  $\frac{1}{2}$ " Bolts 19 out of engagement with the Bolts on Collar 20. At the same

time the Angle Bracket 16 is raised out of engagement with Rack Strip 12, which together with the layshaft slides under the action of the Compression Springs.

Reverse gear is taken through the  $\frac{1}{2}$ "  $\times$   $\frac{1}{2}$ " Pinion and 57-teeth Gear and the three  $\frac{1}{2}$ " Pinions outside the frame of the gear-box. Bottom gear is provided by the  $\frac{1}{2}$ "  $\times$   $\frac{1}{2}$ " Pinion, 57-teeth Gear,  $\frac{1}{2}$ " Pinion 10 and the other 57-teeth gear on Rod 4. Second gear

is given by meshing the  $\frac{3}{4}$ "  $\times$   $\frac{1}{2}$ " Pinion with the 57-teeth Gear on the layshaft, and the  $\frac{3}{4}$ " Pinion on the layshaft with the 50-teeth Gear on Rod 4. Two sets of  $\frac{3}{4}$ " Pinions and 50-teeth Gears are brought into operation for third gear, and top gear is a direct drive through the dog clutch unit.

The dog clutch unit is brought into operation by Crank 7, which is moved by the 57-teeth Gear fixed on the same shaft when the layshaft is placed in top gear position. When the other gears are in operation the Crank does not come into contact with the 57-teeth Gear.

In order to ensure the efficient operation of the gear-box, all moving shafts should be well oiled so that they revolve and slide freely in their bearings. If the layshaft is properly lubricated no trouble will be experienced in operating the various gears, but if the Crank 7 binds on the layshaft the following simple device may be incorporated

to overcome the difficulty. An Angle Bracket is fastened to the upper side-member of the gear-box in the fifth hole from the right (Fig. 380a). A 2" Strip is pivoted to the Angle Bracket by means of a lock-nutted Bolt in its second hole. The longer arm of this Strip is also attached by a set screw to the boss of Crank 7, and a nut is screwed up against the boss so that the set screw is prevented from locking the Crank to the layshaft. An elastic band is attached to the shorter arm of the Strip and to the bolt holding Flat Bracket 13.

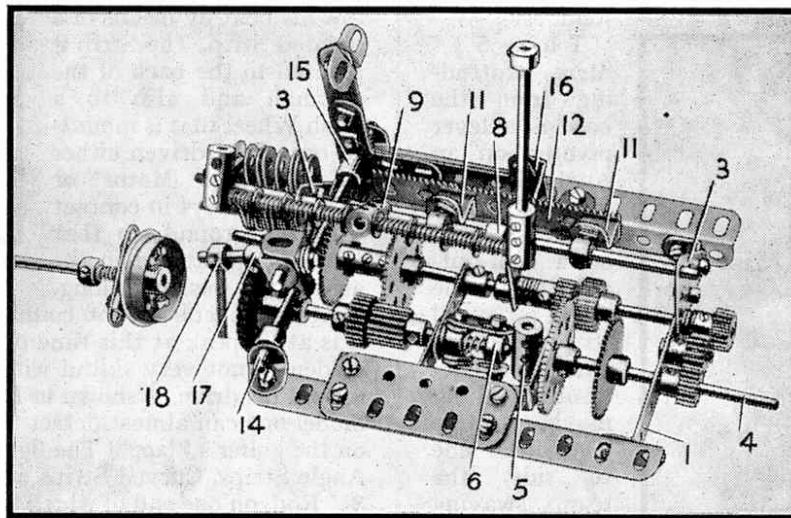

Fig. 380

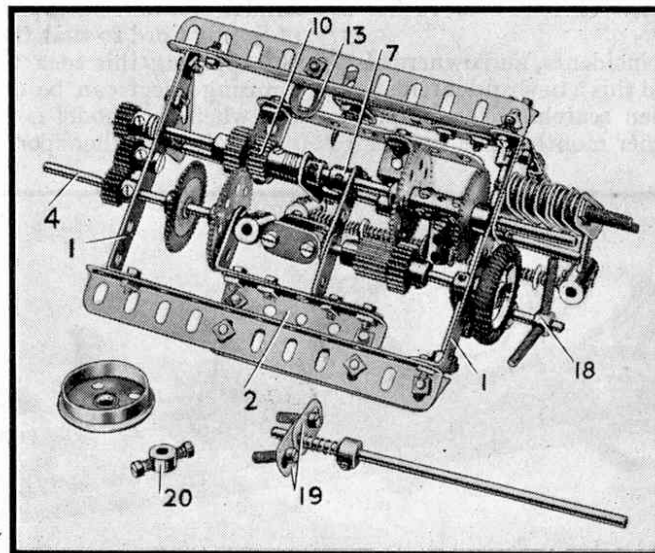

Fig. 380a

**(381) Stroboscope** (A. Carr, Wolverhampton)

The stroboscope is an ingenious instrument that to-day is largely used by engineers for observing mechanisms working at high speed. A revolving wheel or moving parts of machines appear to be stationary when looked at through the instrument if this is properly adjusted. This effect is obtained by viewing the mechanism through a slit, in front of a rapidly revolving shutter, the speed of which can be varied at will. If the shutter is made to rotate at the same speed as the wheel or other moving object it is desired to examine, the eye receives a succession of glimpses of the mechanism at the same point in its rotation. Owing to the persistence of the image formed in the eye, this series of glimpses blends into a continuous steady image. If the speed of the shutter exceeds that of the moving object the image seen by the eye appears in reverse slow motion, but if the shutter speed is reduced to a point slightly below the speed of the object under observation it is seen revolving slowly in the direction in which it actually is moving.

A simple hand-driven model of this mechanism was submitted by A. Carr, of Wolverhampton, and is shown with the back of the casing removed in Fig. 381. In this model, however, the shutter has four slots in it instead of one, so that as the shutter gives four glimpses of the subject under study each revolution, to obtain a still image, it is necessary to rotate the shutter only at one quarter the speed of the subject.

The mechanism is contained in a box, the front of which is built up from  $5\frac{1}{2}$ " Angle Girders connected together at each end by  $2\frac{1}{2}$ " Angle Girders. Two  $2\frac{1}{2}$ "  $\times$   $1\frac{1}{2}$ " Double Angle Strips and two  $2\frac{1}{2}$ "  $\times$   $\frac{1}{2}$ " Double Angle Strips are bolted in the position shown, to form bearings for Rods 1 and 2. The  $2\frac{1}{2}$ "  $\times$   $1\frac{1}{2}$ " Double Angle Strip forming the bearings for Rod 2 is opened out slightly to allow sufficient clearance for the  $2\frac{1}{2}$ " Gear Wheel. Bearings for Rod 3 are provided by two  $2\frac{1}{2}$ "  $\times$   $\frac{1}{2}$ " Double Angle Strips, the lower one being spaced from the  $5\frac{1}{2}$ " Angle Girders by two Washers on each side. The upper one is similarly spaced from the two  $5\frac{1}{2}$ " Flat Girders.

The shutter is a Face Plate carried on Rod 1, and its round holes are covered by fastening bolts in them or by pasting them over with paper. Behind the Face Plate and on the same Rod, is a  $\frac{1}{2}$ " Pinion, and a Collar is fastened on Rod 1 outside the Double Angle Strip that forms the lower bearing.

A  $2\frac{1}{2}$ " Gear on Rod 2, which carries also a  $\frac{1}{2}$ " Pinion, meshes with the  $\frac{1}{2}$ " Pinion on Rod 1, and a second  $2\frac{1}{2}$ " Gear fastened on Rod 3 meshes with the  $\frac{1}{2}$ " Pinion on Rod 2. Rod 3 carries a  $\frac{1}{2}$ " Helical Gear that meshes with a second  $\frac{1}{2}$ " Helical Gear on the  $3\frac{1}{2}$ " Rod 4. Two  $4\frac{1}{2}$ "  $\times$   $2\frac{1}{2}$ " Strip Plates are used to enclose the front and back of the casing.

The stroboscope can either be held in the hand or mounted on a rigid base. An interesting point to note is that if a mark on a revolving disc is viewed through the stroboscope, only one image appears when the shutter is rotating at a quarter of the speed of the disc. When the shutter speed is increased to half that of the disc, two images diametrically opposite to each other are seen. The reason for this is that the shutter gives a glimpse of the mark on the disc at each half revolution. When the speed of the shutter equals that of the disc, four glimpses are seen each revolution, and four separate still images appear, spaced equally round the rim of the disc.

Many interesting experiments can be carried out with the completed instrument. For example, a word written on a piece of paper pasted to a rapidly revolving disc of cardboard can be read quite easily when viewed through the stroboscope, provided that the speed of the shutter is matched exactly to that of the disc.

**(382) Single Suspension Grab** (B. Adair, Maryport)

Most model-builders will be familiar with the single suspension grab used on the Meccano Level-Luffing Automatic Grabbing Crane, and although this mechanism functions excellently when once adjusted, a little difficulty is sometimes experienced in making the correct size knot in the hoisting cord. Model-builders who have had this trouble will be interested in a single suspension grab by B. Adair, Maryport. In addition to entirely eliminating the trouble referred to, the modified grab has the advantage that it is readily detachable from the hoist cord.

The operating mechanism is contained between two 3" Flat Girders spaced by  $1\frac{1}{2}$ "  $\times$   $\frac{1}{2}$ " Double Angle Strips. At the centres of the Flat Girders are 1" Triangular Plates. To the upper pair of these are fastened  $1\frac{1}{2}$ " Strips, across which further  $1\frac{1}{2}$ " Strips are bolted at right angles. The hooks are bolted to Cranks that in turn are fastened to 2" Rods journalled in the second holes from the ends of the 3" Flat Girders. The Rods

carry also the 57-teeth Gears 1 and 3. Between the 57-teeth Gear 1 and the Crank and on the same Rod is a Handrail Support, to which a Coupling is fixed by its grub screws. It carries Rod 2 in its centre plain hole and forms a catch. A length of Spring Cord 5 is held in a Collar at one end of the 3" Flat Girder, and the other end of the Cord is passed into the centre bore of a Coupling secured on the 2" Rod. This is the controlling spring for the catch.

The  $5\frac{1}{2}$ " Strips that form the arms of the grab are pivoted to  $\frac{1}{2}$ " Bolts. The place of the hoist cord used in the Super Model Crane is taken by an 8" Rod, which passes through Double Angle Strip 6 and through the  $1\frac{1}{2}$ "  $\times$   $\frac{1}{2}$ " Double Angle Strips spacing the vertical  $1\frac{1}{2}$ " Strips. The upper end of the Rod carries an End Bearing, and a Collar is fastened to the lower end. The  $\frac{1}{2}$ " fixed Pulley seen in Fig. 382 takes the place of the knot in the hoist cord. The weight of the Rod and Pulley ensures its proper operation.

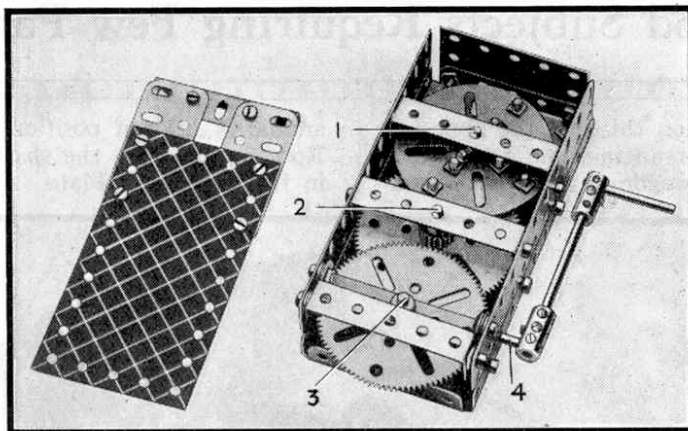

Fig 381

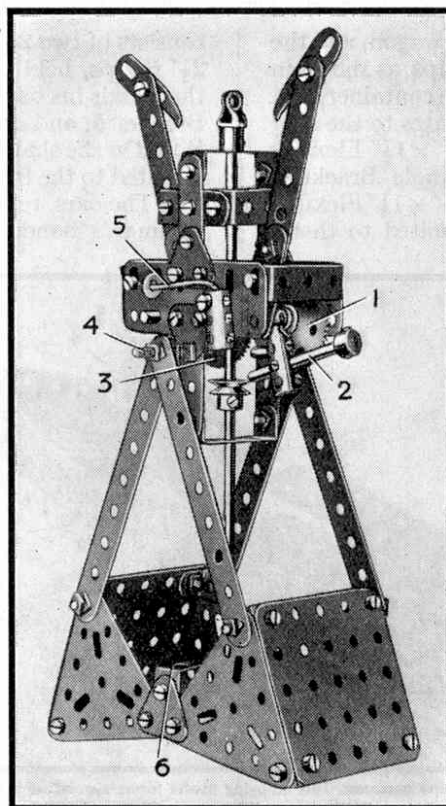

Fig. 382

**Miscellaneous Suggestions**

*Under this heading "Spanner" replies to readers who submit interesting suggestions regarding new Meccano models or movements that he is unable to deal with more fully elsewhere. On occasion he offers comments and technical criticisms that, he trusts, will be accepted in the same spirit of mutual help in which they are advanced.*

**M.195.** L. Cookson, Warwick, submitted recently a suggestion for transmitting the drive from one Rod to another without the use of Couplings. Bush Wheels are secured to the ends of the driving and driven shafts, and a Swivel Bearing is bolted through its boss to a Strip or Plate midway between the shafts. The Collar of the Swivel Bearing is, therefore, pivoted between its forks, and is in line with the bosses of the Bush Wheels. A Rod is passed through the collar so that its ends just engage in diametrically opposite holes in each of the Bush Wheels. When the driving shaft is rotated the Bush Wheel secured on it transmits its motion through the swivel bearing device to the other Bush Wheel. We have tested this arrangement and find that it is satisfactory with Rods 4" or more in length. Shorter Rods than this bind in the holes of the Bush Wheels.

**M.196.** Many model-builders find difficulty in placing nuts on bolts in remote parts of intricate models. J. Stevens of Lowestoft points out that the job is made easy by placing the nut in the arms of a Small Fork Piece, the arms being squeezed together slightly to hold it. The small Fork Piece can then be mounted on a Rod of suitable length to reach the shank of the Bolt. In an alternative arrangement the nut can be gripped in the Fork Piece by means of a nut and bolt passed through the holes in the forks.