

Fig. 1. This fine motor chassis is driven by an E2OR Electric Motor through a two-speed and reverse gear-box controlled by a lever close to the steering column.

## New Meccano Model Motor Chassis

A MOTOR chassis equipped with steering column gear change control, independent front wheel suspension and cable-operated brakes, forms the subject of the new model shown complete in Fig. 1.

Each side of the chassis consists of a  $12\frac{1}{2}$ " Angle Girder 10 and a  $4\frac{1}{2}$ " Angle Girder 11 joined by a  $1\frac{1}{2}$ " and a 1" Corner Bracket to form the arch over the rear axle. The main girders are joined at the rear by a  $4\frac{1}{2}$ " Angle Girder, and at the front by a  $2\frac{1}{2} \times \frac{1}{4}$ " Double Angle Strip placed immediately above the front spring.

Each rear spring consists of a  $4\frac{1}{2}$ ", two  $3\frac{1}{2}$ ", a  $2\frac{1}{2}$ " and a  $1\frac{1}{4}$ " Strip, held together and attached to the rear axle casing by a  $\frac{3}{8}$ " Bolt. An Angle Bracket is bolted to each end of the  $4\frac{1}{2}$ " Strip, and one of them is lock-nutted direct to the chassis. A Fishplate is lock-nutted to the second

Angle Bracket and also to the chassis.

The rear axle is exactly the same as that described in the "Among the Model-Builders" pages of this issue, except that brakes are fitted. Each brake shoe consists of a Bell Crank lock-nutted at 12 to the Wheel Disc at the end of the axle casing. The shoe is held clear of the drum by a  $2\frac{1}{2}$ " Driving Band looped over a  $\frac{1}{2}$ " Bolt 13 and fixed to the Wheel Disc.

The front spring is formed by a  $4\frac{1}{2}$ ", two  $3\frac{1}{2}$ ", a  $2\frac{1}{2}$ " and five  $1\frac{1}{2}$ " Strips curved to shape and attached by a  $\frac{1}{4}$ " Bolt to the centre of the Double Angle Strip across the chassis. The spring forms the lower link of the suspension system, and the upper link is a Swivel Bearing 14. This is attached by a  $\frac{3}{8}$ " Bolt to a Collar that pivots on Bolts 15 passed through Angle Brackets 16 fixed to the chassis. A  $1\frac{1}{2}$ " Rod is fixed in the Swivel Bearing, passed through the end hole of the front spring, and is held in place by a Collar. A Coupling 17 is free to turn on the  $1\frac{1}{2}$ " Rod between the Swivel Bearing and the spring.

The track rod is built up of a  $3\frac{1}{2}$ " Strip and a 2" Slotted Strip bolted together, and is connected by bolts to Collars fixed on the ends of  $\frac{3}{8}$ " Bolts screwed into the Couplings 17. The Bolts are not screwed into the Couplings far enough to grip the  $1\frac{1}{2}$ " Rods, however, and they are locked by nuts tightened against the Couplings. The stub axles are 1" Screwed Rods screwed partly into the Couplings and held in place by nuts. A Wheel Disc is gripped between two nuts on each Screwed Rod, and the front hub is passed over the Rod and held in place by lock-nuts. The hub is a Wheel Flange attached to a Bush Wheel by  $\frac{3}{8}$ " Bolts, which are used also as stud bolts to fix the front wheel to the hub.

The steering column is a  $6\frac{1}{2}$ " Rod fitted with a Worm that meshes with a  $\frac{1}{4}$ " Pinion 18. This Pinion is fixed on a  $1\frac{1}{4}$ " Rod mounted in two  $1\frac{1}{2}$ " Angle Girders 19 bolted to the chassis, and it carries at its lower end a Crank 20. A compound 4" Strip links the Crank to a Collar

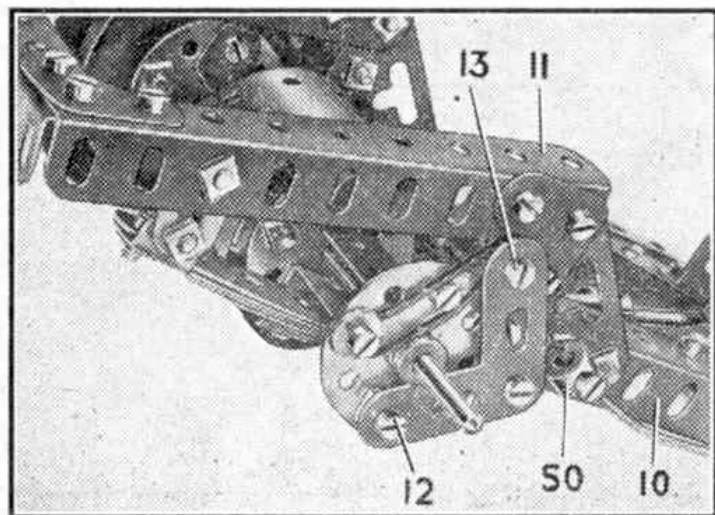

Fig. 2. A close-up of the rear springs and brake assembly.

fixed on a  $\frac{1}{2}$ " Bolt screwed partly into one of the Couplings 17 and locked by a nut.

The lower bearing for the steering column is a Corner Angle Bracket 21 bolted to the chassis, and the upper end is mounted in a bulkhead assembled on a  $1\frac{1}{4}$ " Angle Girder 22 on each side of the chassis. A vertical 3" Angle Girder is attached to each of the Girders 22, and the 3" Angle Girders are connected at their upper ends by two  $3\frac{1}{2}$ " Strips overlapped four holes. A 2" Flat Girder 23 is bolted to one side of the bulkhead, and the steering column passes through this Flat Girder. The column is held in place by Collars.

A  $\frac{1}{2}$ " Pinion on the E20R Motor shaft meshes with a 57-tooth Gear on a  $2\frac{1}{2}$ " Rod 24. This Rod is fitted with a  $\frac{1}{2}$ " Contrate 25.

The gear-box and clutch are built as a unit, and they are housed in a framework formed by two  $3\frac{1}{2}$ " Flat Girders 26 and two  $1\frac{1}{2}$ " Flat Girders 27. These parts are connected together by Angle Brackets, and a  $1\frac{1}{2}$ " x  $\frac{1}{2}$ " Double Angle Strip 28 is bolted across the centre of the gear-box. A  $1\frac{1}{2}$ " Strip is bolted across the slotted holes of the rear Flat Girder 27 at the extreme limit of the slots so that a  $\frac{1}{2}$ " and a  $\frac{1}{4}$ " Pinion mounted on Rods in holes in the Flat Girder mesh accurately. A Flat Trunnion, with its apex upward, is used in place of a  $1\frac{1}{2}$ " Strip at the front of the gear-box, however, and a  $\frac{1}{2}$ " Bolt is fixed by a nut in the apex hole of the Flat Trunnion. A  $\frac{1}{2}$ " x  $\frac{1}{2}$ " Pinion 29 is free to turn on this Bolt and meshes with the Contrate 25.

The gear-box input shaft is a  $2\frac{1}{2}$ " Rod mounted in one of the Flat Girders 27 and in Double Angle Strip 28. It carries a  $\frac{1}{2}$ " Pinion 30 and a  $\frac{1}{4}$ " Pinion 31, and about  $\frac{1}{4}$ " of the Rod projects beyond the Double Angle Strip and into the bore of  $\frac{1}{4}$ " Pinion 32. Pinion 32 is on the output shaft, which is a  $1\frac{1}{2}$ " Rod carrying also a  $\frac{1}{4}$ " Pinion 34. The layshaft is a  $3\frac{1}{2}$ " Rod fitted with a  $\frac{1}{2}$ " Pinion 35, a  $\frac{1}{2}$ " Pinion 36 and a Collar 37.

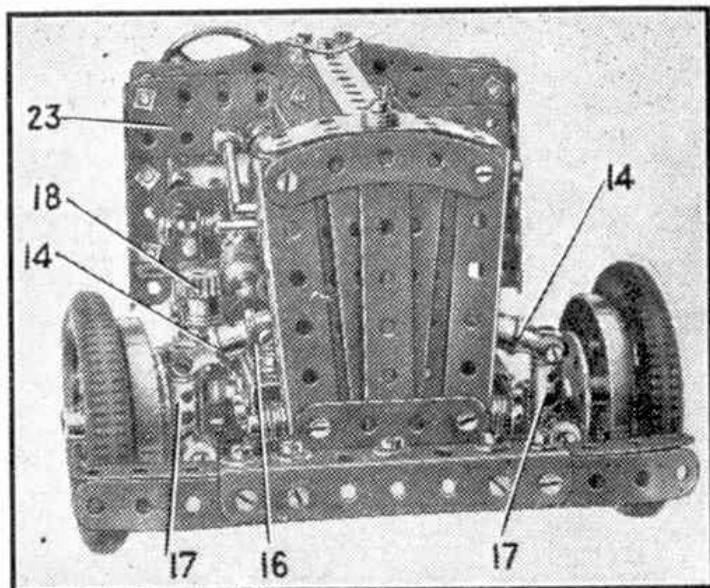

Fig. 3. This view shows the arrangement of the upper links of the independent front suspension.

Movement of the layshaft is controlled by a  $\frac{3}{8}$ " Bolt 38 engaging between Collar 37 and Pinion 36. The Bolt is held by a nut in a Fishplate fitted also with a  $\frac{3}{8}$ " Bolt. A  $1\frac{1}{2}$ " Strip 39 is passed over the  $\frac{3}{8}$ " Bolt but is separated from the Fishplate by three Washers. This assembly is then held tightly by a nut, and the shank of the  $\frac{3}{8}$ " Bolt is passed through a 1" Triangular Plate bolted to the side of the gear-box. Two Washers are used to space the  $1\frac{1}{2}$ " Strip from the Triangular Plate and the  $\frac{3}{8}$ " Bolt is held in place by lock-nuts. The reverse  $\frac{1}{2}$ " Pinion is free on a  $\frac{1}{2}$ "

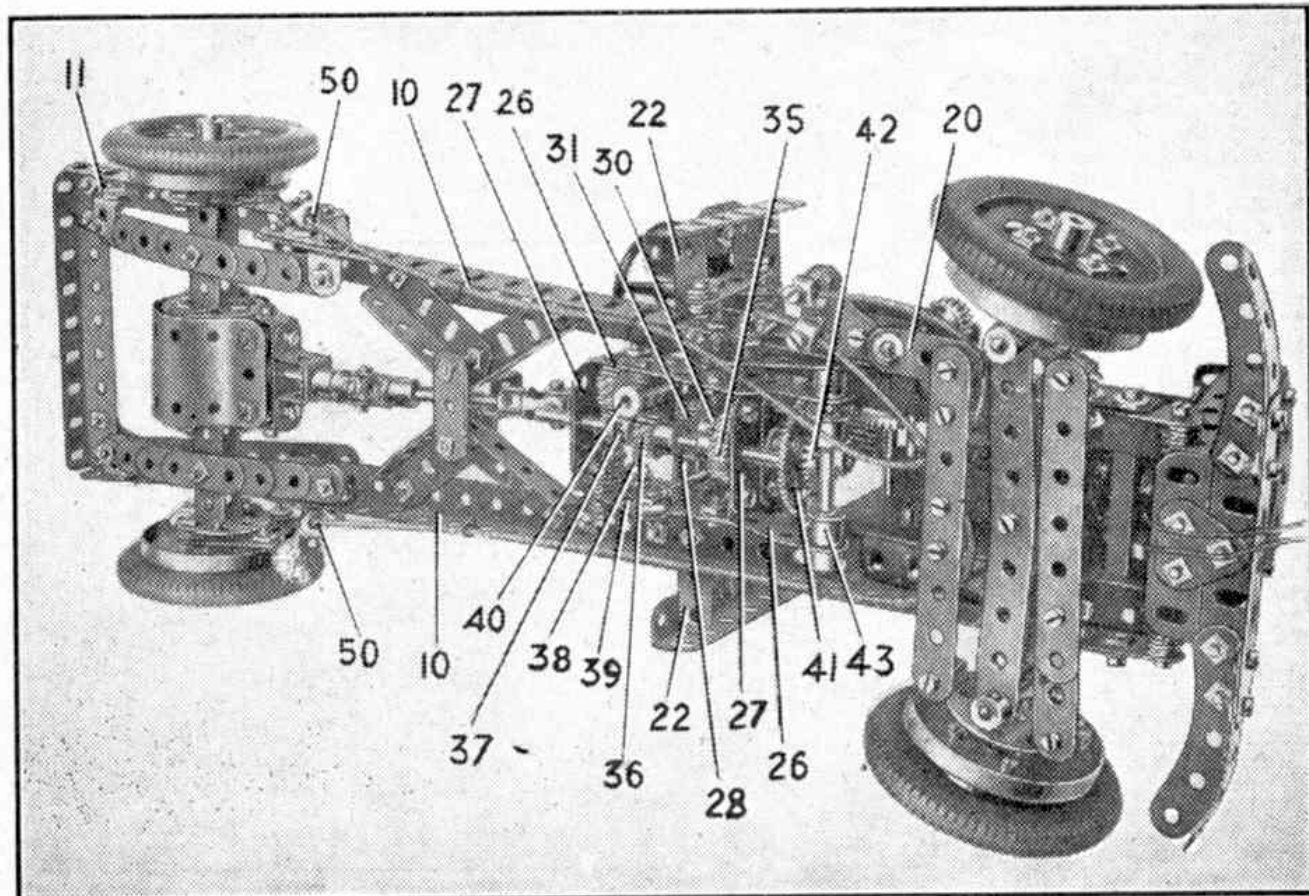

Fig. 4. An underneath view of the chassis showing the steering linkage and details of the clutch and gear-box.

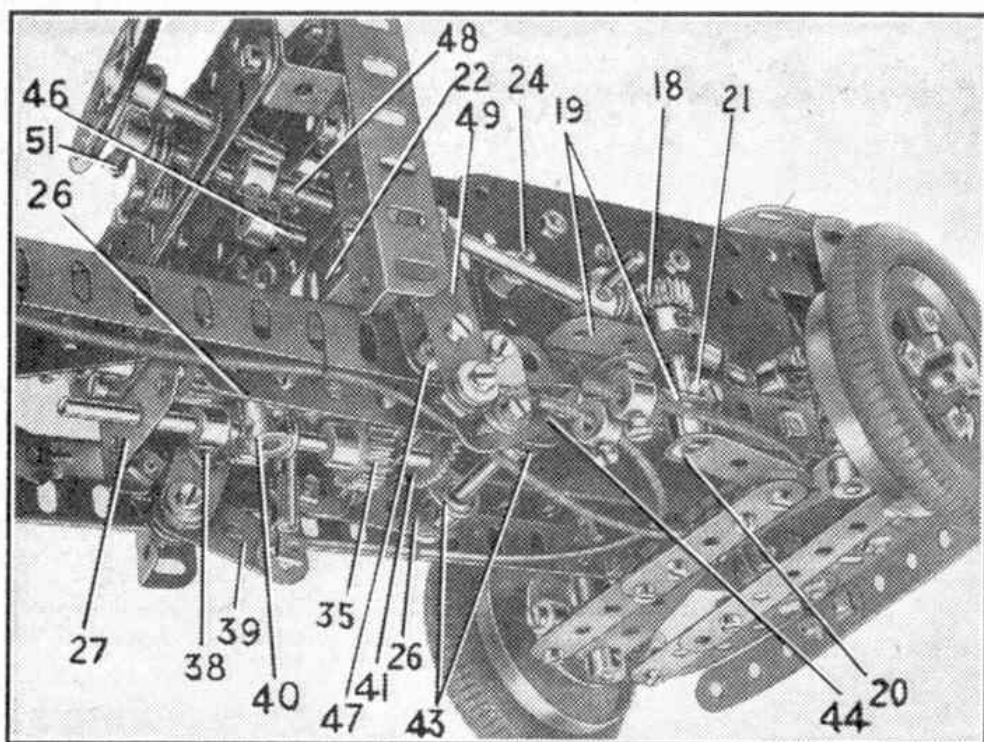

Fig. 5. This view of the model displays the compact clutch and brake pedal assembly and the gear selector levers.

Bolt screwed into the tapped hole of a Coupling 40, and the Bolt is prevented from turning by the grub screw. The Coupling is held by a  $\frac{3}{8}$ " Bolt passed through the side of the gear-box and screwed into the centre tapped hole of the Coupling. The Coupling 40 is spaced from the side of the gear-box by Washers.

The clutch driving member is a 57-tooth Gear 41 meshing with Pinion 29. The Gear is free on the shaft, and the fixed member is a  $\frac{3}{4}$ " Bevel Gear 42. A thin piece of rubber should be glued to the Gear 41 to provide the friction surface. A Compression Spring placed between Gear 41 and the front of the gear-box forces the Gear against the Bevel Gear 42, but it can be withdrawn by Pawls 43. The Pawls are fixed on a  $2\frac{1}{4}$ " Rod mounted in the lower end holes of the Flat Girders 26, and they are operated through a Crank 44 fixed on the same Rod. The gear-box and clutch unit is bolted to the Motor by the end slotted holes of Flat Girders 26, but the Girders are spaced from the Motor side-plates by two Washers on each bolt.

The Motor is attached to the chassis by the same bolts that hold Angle Brackets 16 in place, and the rear of the gear-box is supported by an Angle Bracket 45 clamped between the chassis and a  $1\frac{1}{2}$ " Strip.

The clutch is operated through a 1" Rod 46 fixed in a Rod and Strip Connector lock-nutted to a Bell Crank with boss 47. The brake is operated by a 1" Rod 48 fixed in a Rod and Strip Connector lock-nutted to a 2" Strip 49. A  $\frac{3}{4}$ " Bolt is passed through the 2" Strip and the boss of the Bell Crank and is lock-nutted to the chassis. A Fishplate is lock-nutted to the Bell Crank, and a  $\frac{3}{8}$ " Bolt

fixed by a nut in the Fishplate engages the slotted hole of Crank 44.

The brakes are operated through cables consisting of thin wire passed through an outer sheath formed by Spring Cord. One end of the Spring Cord is clamped in a Collar 50 screwed on to a bolt fixed in the chassis, and the other end is clamped in a Collar screwed to a bolt fixed in a 1" Corner Bracket bolted to the lower of the Girders 19. The wire is fixed to the end hole of the Strip 49 and to the Bolt 13 on the brake shoe.

The brake drums are Wheel Flanges fixed to Bush Wheels by  $\frac{3}{8}$ " Bolts. These serve also as stud bolts for the rear wheels.

Gear selection is controlled by a  $\frac{1}{2}$ " Bolt 51 screwed into a Collar fixed on a 2" Rod, which is mounted in the fascia panel and the bulkhead.

The inner end of the 2" Rod carries a Crank, and a Rod and Strip Connector lock-nutted to it is fitted with a 2" Rod. This Rod passes through the gear-box, and carries at its lower end a second Rod and Strip Connector that is lock-nutted to the gear selector lever 39.

The radiator is assembled from two 3" Angle Girders joined at the top by a  $2\frac{1}{2}$ " Angle Girder and a  $2\frac{1}{2}$ " Curved Strip, and at the bottom by a 2" Angle Girder. It is filled in by five 3" Strips clamped between the  $2\frac{1}{2}$ " Angle Girder and the Curved Strip, and the 2" Angle Girder and a 2" Strip. It is attached to  $1\frac{1}{2}$ " Strips bolted to the chassis and is located centrally by Washers on the Bolts fastening it in position. The radiator is braced to the bulkhead by a  $5\frac{1}{2}$ " Strip extended by a 1" Triangular Plate.

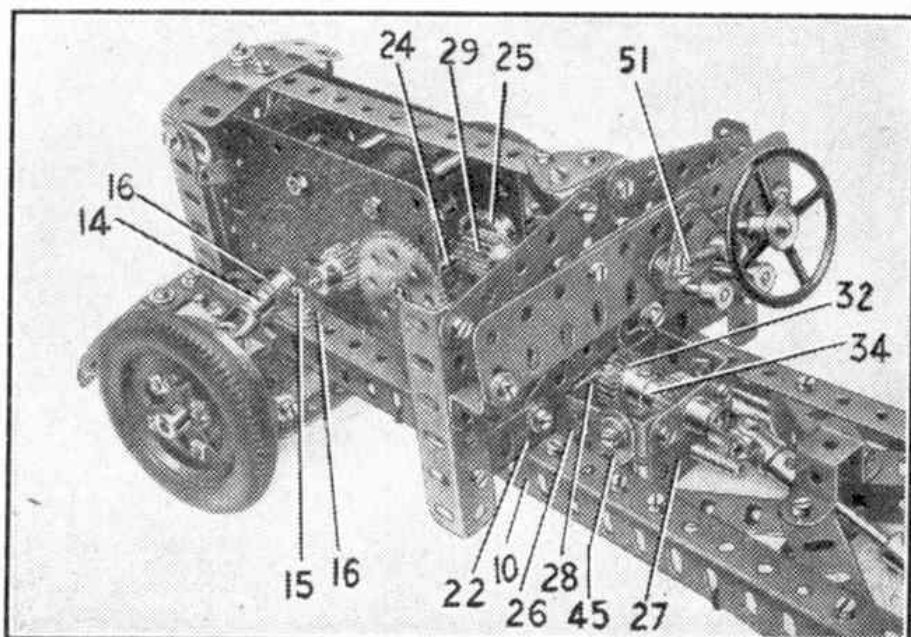

Fig. 6. The arrangement of the reduction gearing between the E20R Electric Motor and the gear-box is seen clearly in this view.

# New Meccano Model

## Electrically Driven Military Light Tank

THIS month's new model represents a light tank and it is a most interesting one to construct and operate. It is driven by an E20R Electric Motor which moves the tracks through a neat and compact differential. This mechanism permits either or both tracks to be driven at will, the selection being effected by a control lever.

The chassis of the model is made from two  $9\frac{1}{2}$ " Angle Girders each extended downward by a  $9\frac{1}{2}$ " Flat Girder, and connected by a  $3\frac{1}{2}$ " Angle Girder 1 and by two  $3\frac{1}{2}$ " x  $\frac{1}{2}$ " Double Angle Strips 2. An E20R Electric Motor is bolted by its flanges to the Double Angle Strips 2 as shown in Fig. 2. The Motor side-plates are extended by  $3$ " x  $1\frac{1}{2}$ " Flat Plates, in which are mounted the shafts bearing the reduction gears.

A  $\frac{1}{2}$ " Pinion on the Motor shaft meshes with a 57-tooth Gear on a Rod that carries also a  $\frac{1}{2}$ " Pinion 3. Pinion 3 meshes with a 57-tooth Gear on a Rod fitted with a  $\frac{1}{2}$ " Pinion 4, which engages a further 57-tooth Gear 5 fixed on a Rod 6 (Fig. 2). A  $\frac{1}{2}$ " Sprocket also fixed on Rod 6 is connected by Chain to a  $1\frac{1}{2}$ " Sprocket forming the driving gear of the differential.

The bearings for the rear axle are provided by the chassis Girders, and by a  $7\frac{1}{2}$ " Angle Girder 7 on each side, each of which is attached to the chassis by two  $2$ " Angle Girders. The differential cage is built up by bolting two  $1\frac{1}{2}$ " x  $\frac{1}{2}$ " Double Angle Strips between a  $1\frac{1}{2}$ " Sprocket and a Wheel Disc. Two  $\frac{1}{2}$ " Pinions 8 are mounted on a  $1\frac{1}{2}$ " Rod passed through the centre holes of the Double Angle Strips, and a Coupling 9 is fixed on

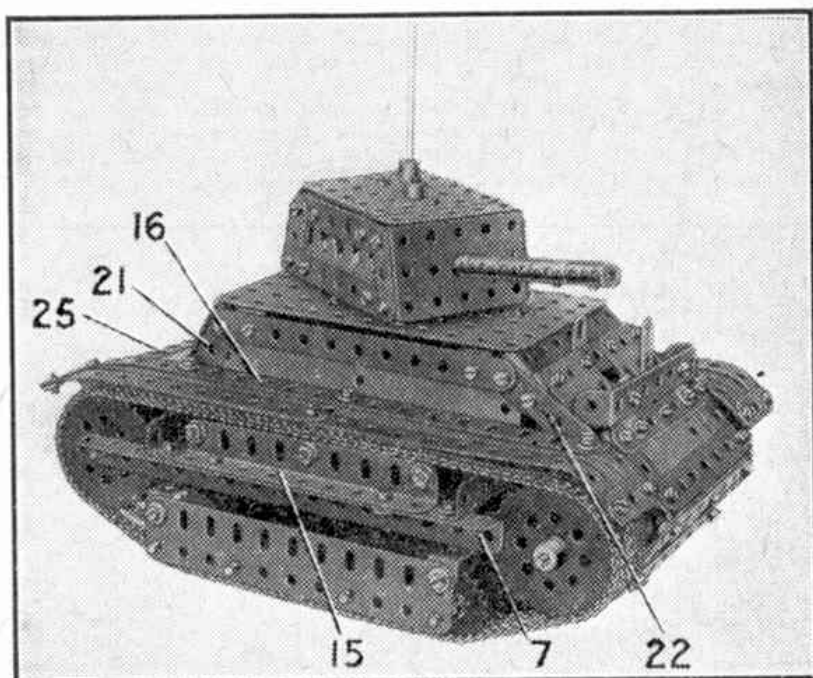

Fig. 1. A light tank steerable by its tracks. The model incorporates a differential transmission to the tracks and is driven by an E20R Electric Motor.

the Rod between the Pinions. One Pinion is free on the Rod and the other is fixed, and both are spaced from the Coupling by two Washers.

The driving axles are passed through Girders 7 and the chassis Girders and into the longitudinal bore of the Coupling 9. A  $\frac{1}{2}$ " Contrate fixed on each axle meshes with the Pinions 8, and four  $2$ " Sprockets are carried on the axles as shown in Fig. 2.

The leading axle is a  $6\frac{1}{2}$ " Rod mounted in the chassis, and it is fitted with two  $2$ " Sprockets on each side. These Sprockets are free to turn and are held in place by Collars, and two  $\frac{1}{2}$ " Bolts are screwed into the boss of each of the inner Sprockets. The Bolts are fixed in position by nuts.

The steering lever is a  $2\frac{1}{2}$ " Strip lock-nutted to a  $1\frac{1}{2}$ " Strip bolted to a Trunnion 10. The Trunnion is fixed to a  $2\frac{1}{2}$ " Flat Girder bolted to the Girder 1, and the bolts serve also to hold a  $2\frac{1}{2}$ " x  $\frac{1}{2}$ " Double Angle Strip 11. A  $3\frac{1}{2}$ " Rod is freely mounted in the Double Angle Strip, and is fitted with two Spring Clips and two Collars 12. A Bolt held by two nuts at the lower end of the steering lever engages between the Collars 12, so that by moving the lever the  $3\frac{1}{2}$ " Rod can slide in its bearings to engage either of the  $\frac{1}{2}$ " Bolts fixed in the Sprockets. This arrangement prevents one track from operating, while the other is still driven

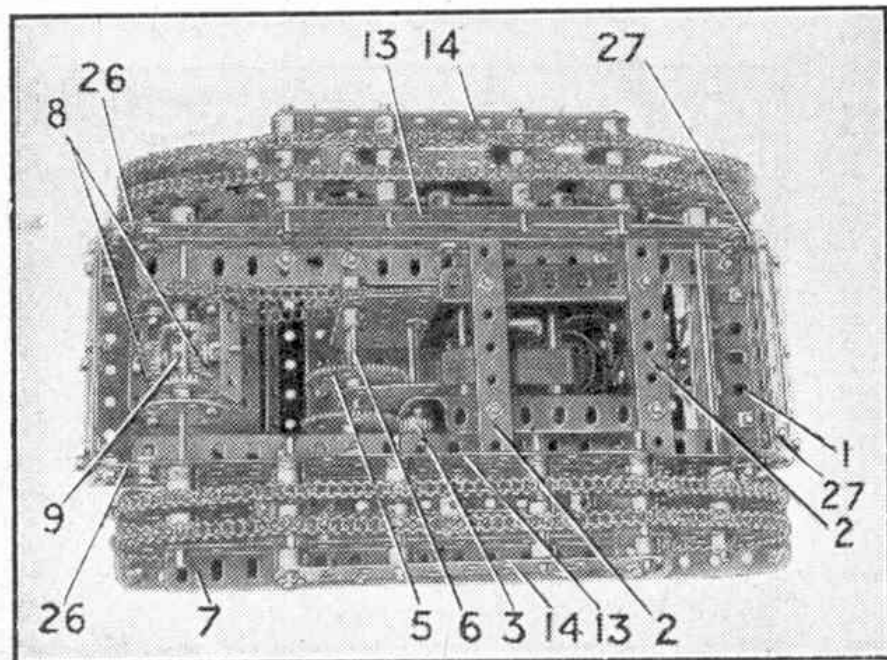

Fig. 2. An underneath view of the tank.

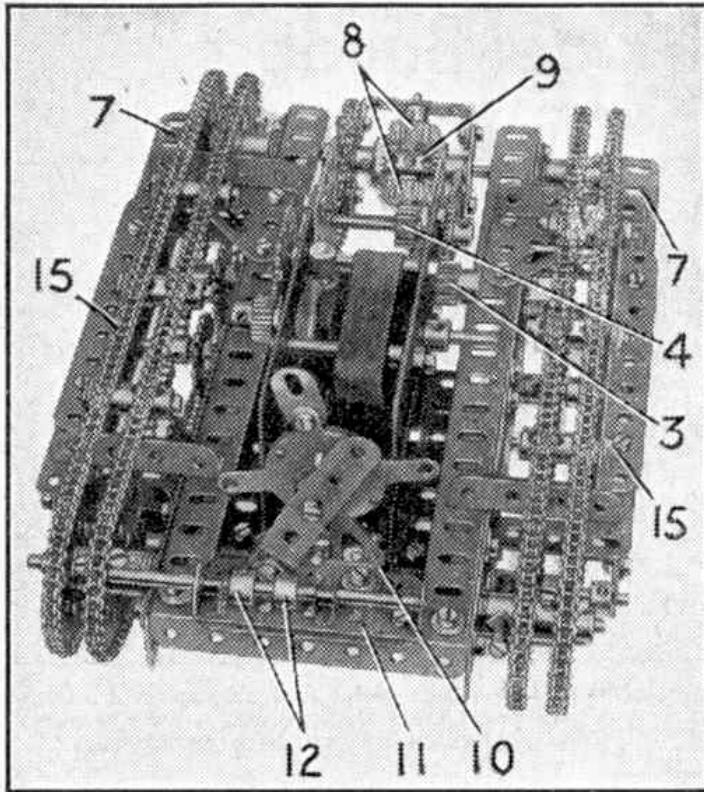

Fig. 3. A front end view of the tank chassis showing the Motor switch and the control for the tracks.

through the differential to steer the model in the desired direction.

The model is supported on four sets of idler sprockets on each side. Each set consists of two 1" Sprockets fixed on a 2" Rod mounted in two 5 1/2" Flat Girders 13 and 14. Flat Girder 13 is bolted direct to one of the 9 1/2" Flat Girders of the chassis, and Flat Girder 14 is attached to two 1 1/2" x 1/4" Double Angle Strips fixed to the chassis. The Sprocket Chain representing the tracks passes round the 1" and 2" Sprockets, and is supported at the top by three rollers, each consisting of a Coupling loosely mounted on a 1 1/8" Bolt. The Bolts are attached by nuts to 1/2" Angle Girders 15 bolted to Girders 7.

The body is assembled as a separate unit and is fixed in position when the chassis is complete. The sides are 5 1/2" x 1 1/4" Flexible Plates bolted to 7 1/2" Angle Girders 16, and braced along their upper edges by 5 1/2" Strips. The sides are spanned by 3 1/2" x 1/4" Double Angle Strips 17, 18, 19 and 20, Fig. 4. The sloping ends are provided by two 2" Slotted Strips 21 and two 2 1/2" Strips 22. These are bolted to the upper corners of the 5 1/2" x 1 1/4" Flexible Plates, and to the ends of the Girders 16.

The rear of the body is completed by two 2 1/2" x 1 1/4" Flexible Plates 23, overlapped three holes and bolted to a 3 1/2" x 1/4" Double Angle Strip fixed between Girders 16. A 3 1/2" x 2 1/2" Flexible Plate, braced by 2" Angle Girders 24, is attached to the Plates 23 by Obtuse Angle Brackets, and the rear edge of the 3 1/2" x 2 1/2" Flexible Plate is braced by a 3 1/2" Angle Girder 25. The latter is extended downward by two 2 1/2" x 1 1/4" Flexible Plates overlapped three holes and edged by two 1 1/2" Angle Girders and a 3 1/2" Strip. The front of the body is completed as shown in Figs. 1 and 4,

and the top is filled in by a 5 1/2" x 3 1/2" Flat Plate fixed to Double Angle Strips 17.

The track covers are 5 1/2" x 1 1/4" Flexible Plates edged by Strips and bolted to Girders 16.

The sides of the turret are made from one 3 1/2", one 3" and two 1 1/2" Strips, and a 2 1/2" Flat Girder. The ends are 2 1/2" x 1 1/4" Flanged Plates and the top is made from two 2 1/2" x 2 1/2" Flat Plates overlapped four holes. The top is fixed to 2 1/2" x 1/4" Double Angle Strips bolted between the sides. The gun consists of Couplings fixed on a Rod held in a Rod Socket.

The turret swivels on a Rod fixed in a Bush Wheel attached to the top of the body.

A Collar is fixed on the Rod underneath the turret so that it is held clear of the bolt heads in the 5 1/2" x 3 1/2" Flat Plate forming the top of the body. A second Collar on the Rod is used to hold the turret in position.

The complete body is attached to the chassis by Fishplates 26 and Angle Brackets 27 (Fig. 2).

Forward and reverse drives are obtained by operating the E20R Motor reversing switch, which is extended by a Fishplate that projects through a slot in the body. The steering lever in its central position allows both tracks to be driven at the same speed, but when the lever is moved sideways one or other of the tracks is prevented from turning. The free track is then driven at increased speed through the differential mechanism and the model will pivot on the stationary track.

It is important to make sure that each track Chain has exactly the same number of links. The teeth of the Sprockets fixed on the driving and idling axes should be in line.

Parts required to build the model Light Tank: 6 of No. 2; 7 of No. 3; 2 of No. 4; 5 of No. 5; 2 of No. 6; 13 of No. 6a; 2 of No. 8a; 4 of No. 8b; 2 of No. 9a; 2 of No. 9b; 6 of No. 9c; 2 of No. 9f; 3 of No. 10; 2 of No. 12; 6 of No. 12c; 1 of No. 14; 2 of No. 16; 2 of No. 16a; 2 of No. 16b; 12 of No. 17; 1 of No. 24; 2 of No. 25; 3 of No. 26; 3 of No. 27a; 2 of No. 29; 2 of No. 35; 141 of No. 37; 27 of No. 37a; 95 of No. 38; 6 of No. 48; 3 of No. 48a; 10 of No. 48b; 2 of No. 51; 1 of No. 52a; 2 of No. 55a; 15 of No. 59; 11 of No. 63; 2 of No. 72; 2 of No. 73; 2 of No. 94; 8 of No. 95; 1 of No. 95a; 16 of No. 96; 1 of No. 96a; 4 of No. 103; 2 of No. 103a; 3 of No. 103f; 2 of No. 103h; 5 of No. 111; 4 of No. 111a; 6 of No. 111d; 1 of No. 126; 2 of No. 133; 2 of No. 179; 8 of No. 188; 6 of No. 189; 1 of No. 190a; 1 of No. 219; 1 E20R Electric Motor.

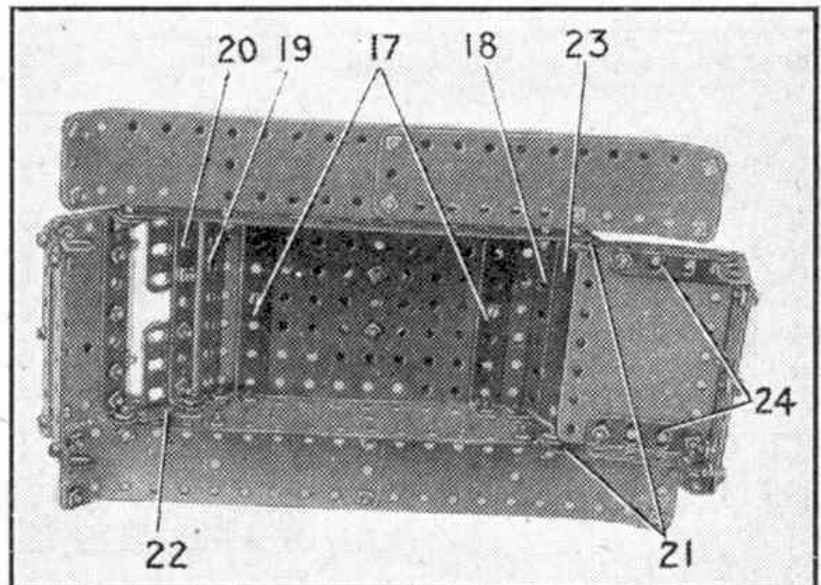

Fig. 4. The tank casing seen from the interior.