

MECCANO MAGAZINE

2^D
VOL. IX
N° 10



OCTOBER 1924

You'll be happy with a Fretwork Outfit!

A delightful and useful hobby for every boy

You can make spare pocket money at it

Hobbies supply Outfits complete from 4/- to 57/6

Don't buy cheap or inferior foreign goods

Free Designs are given every week with *Hobbies*

Write for Free Lists and Booklet to Dept. 96,

HOBBIES LTD., DEREHAM, NORFOLK

65, New Oxford St., London, W.C. ; 147, Bishopsgate, London, E.C. ; 79, Walworth Road, London, S.E. ; 326, Argyle Street, Glasgow ; 10a, Piccadilly, Manchester ; 9a, High Street, Birmingham ; 15, County Arcade, Leeds ; 11, Bridge Street, Southampton ; 68, London Road, Brighton, and agents in every town.

The A1.
OUTFIT
COMPLETE
Price - 16/6

Postage 1/- extra.

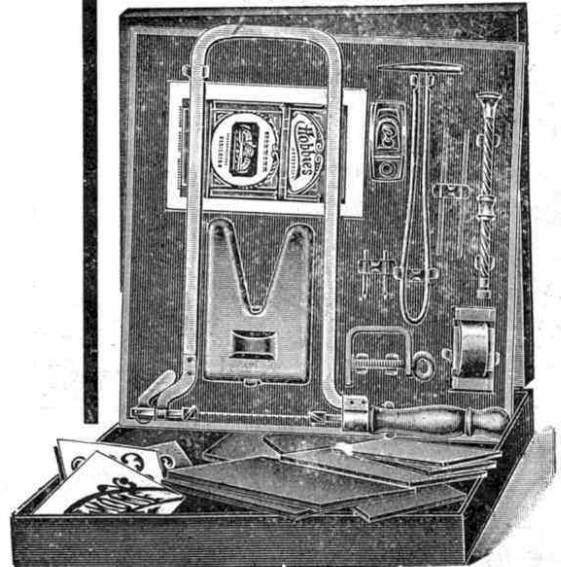

Hobbies 14in. Patent Lever Hand-frame ; Drill with two Bits ; Cutting Table ; two Dozen Hobbies Saw-blades ; No. 1 Plane ; Fretwork Hammer ; Sandpaper Block ; Illustrated Handbook, containing full particulars of Tools, Materials, etc., with clear Instructions ; and Six Fretwork Designs, with sufficient Planed Fretwood for making them.

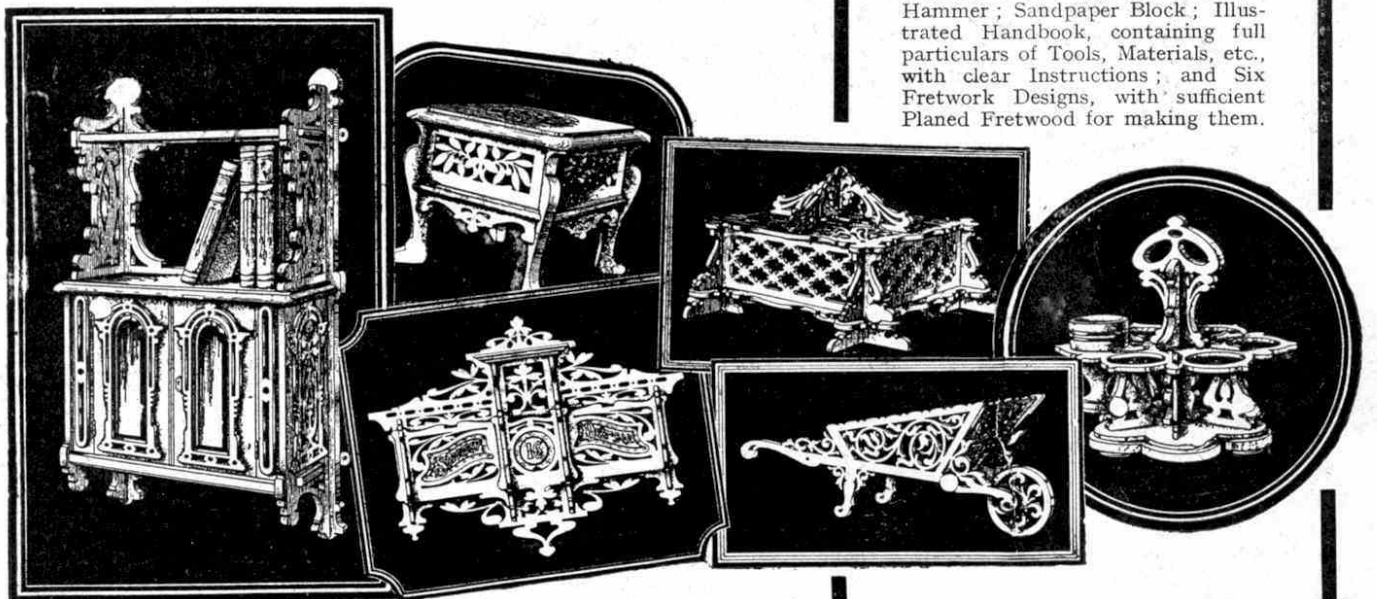

EDITORIAL OFFICE
Binns Road,
LIVERPOOL



MECCANO

MAGAZINE

PUBLISHED
IN THE INTERESTS
OF BOYS

Vol. IX. No. 10.

October 1924



EDITORIAL

THIS month our cover illustrates a giant steam-shovel at work on the site of the Panama Canal. Steam-shovels, which have made possible the construction of many works, including the Panama and the Manchester Ship Canals, are of great service to the engineer when it is necessary to excavate or remove large quantities of material. The fact that the modern steam-shovel is able to accomplish in a day as much work as 2,000 men could accomplish in the same time with picks and shovels, is a very important consideration for the engineer, enabling him to tackle great undertakings that would be impossible if these mechanical navvies were not employed. In the cutting of the Panama Canal, for instance, over 80 shovels were employed, and as each shovel requires only a few men to look after it, the economy in accommodation and transport of the workmen was very great. A special article on the story of the Panama Canal that I hope to publish in the near future will enable my readers to understand the great debt that civilisation owes to these monster steam-shovels, which, by the way, were fully described in our issues of January and February last.

On page 284 will be found full instructions for building a Meccano model of one of these wonderful engineering appliances. I have seen one of these models of a steam-shovel at work and can assure my readers that it is one of the finest models that have ever been built in Meccano. It embodies several interesting features—including roller-bearings—and use is made of a new part, the Circular Strip, supplies of which will be available in the near future. This splendid model is most realistic, and I hope as many readers as possible will build it during the coming winter. Incidentally I may here remark that entries for the special Drag-line competition which closed yesterday (30th September) have been received in large numbers, and I hope to announce the result of the contest next month.

In this issue I publish the first of a series of articles on the Hornby Train system. I have no doubt that these articles will have a very enthusiastic reception, for during the past twelve months I have received hundreds

of letters from readers in almost every part of the world asking for something on these lines. The object of these articles is to indicate how to obtain the most fun from a Hornby set. Among other things they will show how complete railway-like layouts may be built up from the various components of the Hornby Train system. Every month this comes closer to perfection. New accessories are continually being added to the large number already in existence, and the system is steadily developing on the same sound lines as those on which the Meccano system has developed. The first article deals principally with the various types of locos and their mechanism, and future instalments will review the whole system step by step. Having prepared the ground, as it were, different types of track-layouts will be illustrated and described, with full details showing how to make the best use of points and crossings, signals, etc., and suggested schemes of working to a time schedule.

Last month I spent a very enjoyable holiday in a walking tour on the Yorkshire Moors. I did not expect to find any traces of engineering and similar works in such a lonely place, and you may imagine, therefore, how surprised

I was to come across evidence of a wonderful engineering feat amid the heather and the bracken. This was a Roman road, lying between Levisham and Goathland and recently uncovered by the Government Department that is charged with the preservation of our ancient buildings, monuments, and the like. The road, which has been uncovered for a distance of 1½ miles, is 16 ft. in width and consists of large flat pieces of stone. Probably the top surface has been removed and these stones were the foundation of the old road. However that may be, the road to-day resembles a huge "crazy-pavement" such as is laid down in old-world gardens. It is believed that the road was made by the soldiers of the Vth Legion, who were stationed at York and were famous for works of this kind. As I walked the length of the road I could not help thinking of the wonderful engineering ability of those Roman soldiers, who were able to construct such fine roads all over the country and so keep this country in subjection, hundreds

of years ago. I could almost see the Roman soldiers marching along this road across the moors—which were there in their time—on their way to relieve the garrison on the great Roman wall, built, you will remember, to hold the inhabitants of Scotland in check. Another link with engineering, not far distant from the old road, was an old iron mine and iron works, now closed down but at one time the centre of a thriving industry. Close to it was a curious railway, one of the first of its kind and built about the same time that Stephenson opened the Stockton and Darlington line. On this moorland railway the trains were hauled by horses, and it was not until several years later that the steam engine was employed here, as the farmers and dwellers on the moorland naturally preferred horses to the newly-invented steam engines, which they could not understand.

I saw many other interesting things on my walk, which, however, were not connected with engineering. At one place, for instance, there were some 60 bee-hives that had been brought on to the moors in order that the bees might gather heather-honey for their owners. As a rule bee-hives contain over 50,000 bees, so my readers will easily understand that the air was literally full of flying bees, and that the humming of their wings could be heard from a considerable distance. There were butterflies and moths innumerable, flying about the heather, and numbers of the fine green caterpillars of the Emperor Moth, measuring over three inches in length and decorated with orange and mauve spots. I brought some of these home with me and also several specimens of the wonderful "Sun-Dew," the plant that catches and "eats" flies and other small insects. Some day I hope to be able to describe some of these marvellous things in our Nature Study page, for which there has been an increasingly insistent demand during the past few months.

Next Month :

- FAMOUS ENGINEERS :—
Telford.
- ELECTRIC BELLS, INDICATORS AND BURGLAR ALARMS
- SOME RECENTLY-ISSUED STAMPS
- NEW MECCANO MODEL :—
Boat-Launching Gear
- A WONDERFUL NEW COALER, etc.
- COMPETITIONS, GUILD NEWS, CYCLING NOTES, PUZZLES, and other regular features



IX. JAMES BRINDLEY: The First English Canal Engineer

THE Duke's first canal aroused no opposition, but his proposed canal to connect Manchester with the Mersey met with considerable hostility. Its chief opponents were the proprietors of the Mersey and Irwell Navigation, who saw that this proposed canal seriously threatened their monopoly, for so long as they owned the only waterway they could charge what rates they liked.

At first the Navigation tried to buy off the Duke by concessions. They offered to make a great reduction in their rates for coal and other materials, conveyed upon the Irwell between Barton and Manchester, if he would arrange for his canal to join their Navigation at Barton and abandon the portion of his canal between there and Manchester. When this offer was rejected they offered him exclusive advantages in the use of their Navigation, but all to no purpose, for the Duke was determined to go on with his scheme.

The Navigation proprietors had many influential supporters, but they had made themselves unpopular by extorting the highest possible rates for transport and by their high-handed methods. On the other hand, the Duke's scheme was supported by a number of petitions from those who had suffered from the Navigation monopoly.

A Novel Demonstration

A Parliamentary Committee was appointed to investigate the Duke's scheme, and Brindley had to go up to London to appear before the Committee. Unfortunately there is no record of Brindley's evidence, but some amusing stories are told of him on other occasions. For instance, when he was asked for a drawing of a proposed bridge, he replied that he had no plan on paper, but he could illustrate it by a model. He then went out and bought a large cheese, and on his return to the room he cut the cheese into equal parts, saying "Here is my model." The two halves of the cheese represented the semi-circular arches of the bridge, and by laying over them a long rectangular object he was able to demonstrate to the Committee the position of the river flowing below

the bridge and the canal passing over it.

On another occasion, before a Committee of the House of Lords, a Peer asked him to explain the working of a lock. Brindley promptly produced a piece of chalk and

In our last two issues we gave details of Brindley's early life, when he was apprenticed to a millwright, and of his great work in the construction of the Bridgewater Canal from Worsley to Manchester. Brindley, although a self-taught man and the son of a crofter, had a remarkable genius for canal construction. He was also possessed of the dogged determination that is so necessary a quality in the successful engineer.

made things quite clear by drawing diagrams on the floor! He was always ready with a piece of chalk to illustrate his arguments, and it became a common saying in Lancashire that "Brindley and chalk would go through the world."

In spite of all opposition the Bill for the Duke's canal was passed, and it received the Royal Assent on 4th March, 1762.

Brindley Encounters Difficulties

The canal between Worsley and Manchester, although a very bold scheme for its period, had presented few engineering

difficulties. The new canal to the Mersey was a very different affair, however, and its course of about 24 miles bristled with difficulties, including the crossing of brooks, rivers, and bogs. The worst bog to be crossed was Sale Moor, where the bottom was of quicksand.

The construction of the canal at that point was probably almost as formidable an undertaking as the laying of George Stephenson's railway over Chat Moss, some 60 years later. As was the case with Stephenson, Brindley regarded difficulties merely as obstacles to be overcome, and he never relaxed his grip on them until they were surmounted.

George Stephenson made a practice of securing a level track for his railways whenever possible, and in the same manner Brindley aimed at securing long, uninterrupted, level stretches of water in his canals. Brindley's idea was to construct a level of dead water all the way from Manchester to a point as near the Mersey as possible, and to concentrate all his locks near Runcorn where the canal descended to the Mersey. Locks provide a means of raising or lowering boats from one stretch

of a canal to another stretch at a different level. Their working is extremely interesting, but as we have not sufficient space here to deal with the subject adequately, we intend to devote a special article to it in a subsequent issue of the "M.M."

An Embankment Problem Solved

The new works began at Longford Bridge, from where the canal was carried across the valley of the Mersey upon an embankment about a mile in extent. The conveying of the great quantities of earth required to form this embankment was a big problem, and the manner in which Brindley dealt with it was another instance of his great engineering ability and ingenuity.

He had the material brought in special twin boats from other parts of the canal where there was an excess owing to extensive cutting. These twin boats were fixed side by side about two feet apart, and between them was carried a triangular trough capable of containing some 17 tons of

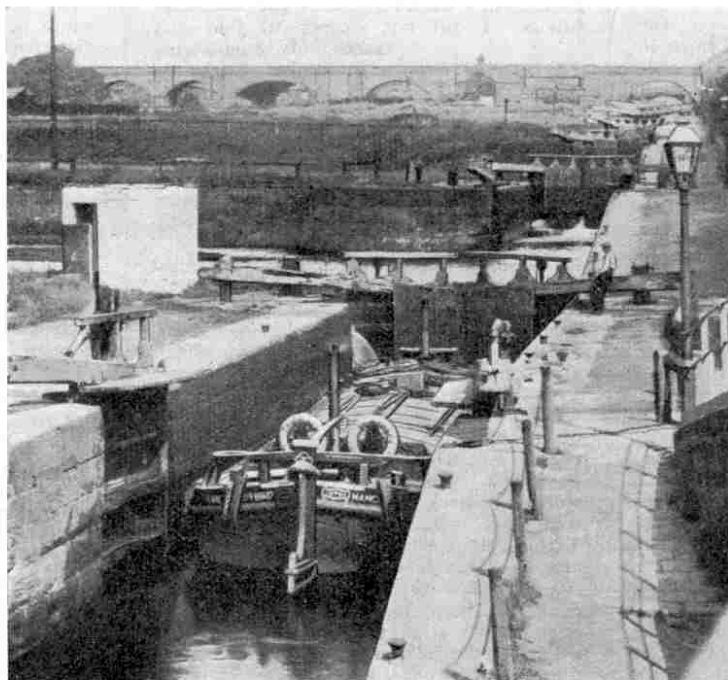

The Flight of Locks at Runcorn

earth. The bottom of this trough was arranged to open on the withdrawal of a pin. When the boats arrived at their destination they were conducted from the canal into water-tight caissons placed at the point over which the earth had to be deposited. The trough pin was then withdrawn and the material was discharged in an instant. To carry out this work by road would have occupied all the horses and carts in the neighbourhood for years.

The work of construction went on very rapidly, between 400 and 600 men being regularly employed. Brindley himself, judging from the entries in his notebooks, appears to have almost lived on the works.

The cost of the undertaking was, of course, very great, and after a while the Duke found himself in difficulties about money. Fortunately, however, he was able to borrow a sufficient amount from a London bank to carry on the works. The entire level length of the canal to the upper part of Runcorn was finished and opened for traffic in 1767, five years after the passing of the Act, but the long flight of locks down to the Mersey was not completed until several years later, by which time the Duke's receipts from the sale of his coal had restored his financial position.

Opening of Runcorn Locks

A letter written from Runcorn on 1st January, 1773, says: "Yesterday the locks were opened and the 'Heart of Oak,' a vessel of 50 tons burden, for Liverpool, passed through them. This day upwards of 600 of his Grace's workmen were entertained upon the lock banks with an ox roasted whole and plenty of good liquor. The Duke's health and many other toasts were drunk with the loudest acclamations by the multitude who crowded from all parts of the country to be spectators of this astonishing work."

The total cost of completing the canal from Worsley to Manchester and the canal to the Mersey amounted to £220,000. To us to-day it appears an astonishing fact that this great canal undertaking, which ultimately produced an income of £80,000 a year, was planned and carried out by Brindley at a rate of pay very much lower than that of an ordinary mechanic of the present day!

The Barton Aqueduct To-day

The Duke of Bridgewater died in 1803, and his canal was worked by trustees until 1889, when the Manchester Ship Canal Co. bought it. Since that time Brindley's aqueduct has been replaced by one of the most remarkable engineering structures in the world. This is a steel aqueduct capable of holding a section of the water of the canal, along with any boats that may happen to be on it at the

time. The section is closed and the water held in it by means of lock gates at each end so that when desired it may be swung clear of large ships that are passing along the canal beneath. This wonderful aqueduct was illustrated in our last issue.

While the canal to the Mersey was under construction, Brindley made surveys for a proposed canal to pass through Cheshire and Staffordshire, to open up communication between the Mersey and

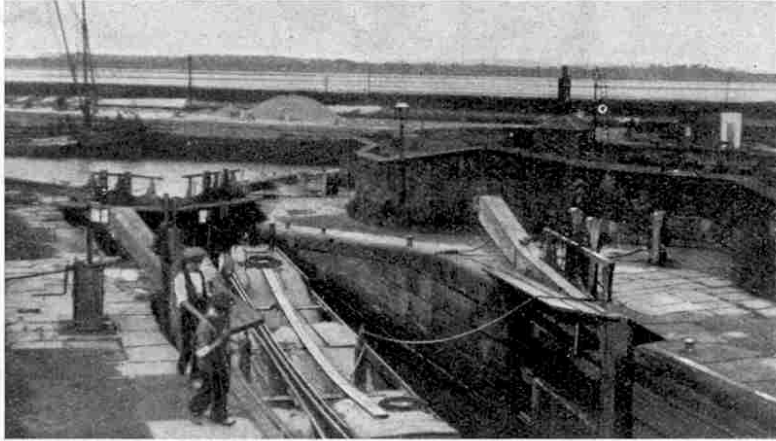

A boat in the Lock, descending to the river

the Trent, and between both these rivers and the Severn.

Difficult Transport in Potteries

The earthenware industry in Staffordshire had already made considerable progress, but it was seriously hampered by transport difficulties, as was also the salt trade in Cheshire. At that time the Staffordshire roads were barely passable by wagons in summer, and scarcely passable at all in winter, even by pack-horses. The chief materials used in the making of pottery came from a great distance. The flints were brought from

and the remainder of the journey in each case had to be made by road.

The manufactured articles were distributed by similar means. The pottery had to be carried by road in crates slung across horses' backs, and in addition to the high cost of transport there was a great risk of loss by breakage or theft.

The immediate success of the Duke of Bridgewater's canal caused a revival of the Staffordshire canal project, and the salt and the earthenware manufacturers entered into co-operation with the principal landowners to push the scheme forward.

The Grand Trunk Canal

Brindley's plan for a canal was not adopted until after great controversy, however, for rival schemes were put forward. Among Brindley's chief supporters were the Duke of Bridgewater, Earl Gower, and Josiah Wedgwood, the famous maker of pottery, to whom we have already referred. A long Parliamentary struggle followed, but ultimately Brindley's plan was selected as being the best, and an Act authorising the construction

of the canal was passed.

The Grand Trunk Canal, as Brindley named it, was the biggest undertaking of the kind yet attempted in England. Its length, including the junctions with the Birmingham Canal and the River Severn, was nearly 140 miles. Starting from the Duke of Bridgewater's canal at Preston-on-the-Hill, near Runcorn, it passed through the salt-manufacturing districts of Cheshire to the summit at Harecastle. From there it descended into the valley of the Trent, passed through the Potteries, and finally established communication with the Trent and the Severn.

Following his usual practice, Brindley concentrated all his locks on the summit at Harecastle. The rise of the canal from the level of the Mersey to Harecastle was 395 ft., and the fall from there to the Trent at Wilden nearly 289 ft. Ultimately 35 locks were built on the northern side of Harecastle and 40 on the southern side.

A Great Tunnel Achievement

The most serious engineering difficulties of the canal were the five tunnels—Harecastle 2,880 yards in length; Hermitage 130 yards; Barnton 560 yards; Saltenford 350 yards, and Preston-on-the-Hill 1,241 yards.

The Harecastle tunnel involved the most difficult work in the whole undertaking, and it was confidently asserted by the defeated proprietors of the rival canals that its construction was impossible. Brindley, who did not admit the existence of the word "impossible," tackled the tunnel as soon as the Act was passed, and steady progress was made. At the same time work was carried on at other parts of the



The Lock-gates opened, allowing the boat to emerge on the river level

the south-eastern ports of England by sea to Hull, and from there up the River Trent to Willington. The clay came from Cornwall and Devonshire and had two possible routes. Most of it came by sea to Liverpool and up the River Weaver to Winsford in Cheshire; the remainder was brought from Bristol up the River Severn to Bridgnorth and Bewdley. The last-mentioned place on each of these routes was the farthest point to which flint or clay could be brought by water,



Electricity

VIII. HYDRO-ELECTRIC POWER STATIONS

In our issue last month we described the general features of an Electric Power Station in which the motive power used to drive the electric generators was steam, produced by the combustion of coal. Now we must see how the vast stores of energy in various parts of the world in the form of water power are utilised for the same purpose.

Lord Kelvin and the Niagara Falls

As soon as water power is mentioned one nearly always thinks of the gigantic falls at Niagara, where the total flow of water is about 270,000 cubic ft. per second. If the whole of this enormous power were utilised it would be sufficient to produce over seven-and-a-half million horse-power. Only 56,000 cubic feet of this vast flow is allowed to be used for power purposes, however, and of this Canada takes 36,000 cubic ft. and the United States 20,000. We therefore continue to be a long way from the time when the ideal of Lord Kelvin will be realised. "I look forward," said he, when at Niagara Falls, "to the time when the whole water from Lake Erie will find its way to the lower level of Lake Ontario through machinery, doing more good for the world than that great benefit that we possess in the contemplation of the splendid scene now presented by the waterfalls of Niagara."

Another famous electrician, Sir William Siemens, on visiting Niagara, had a similar vision. Although the mighty rush and roar of the waters filled him with awe, his keen brain instantly grasped the possibilities of the falls from a power-giving point of view, and he felt that the time must inevitably come when such a tremendous natural source of power could no longer be neglected.

Nature's Greatest Source of Power

Niagara has long been regarded as the world's greatest natural source of power, but it was not until 1842 that a practical scheme for utilising this power was put forward. In that year one Augustus Porter proposed the construction of a series of canals above the Falls. These were intended to lead the water down over large water-wheels, which were to drive machinery. After a good deal of

negotiation a canal was constructed, 35 ft. in width, 8 ft. in depth and 4,400 ft. in length, and by 1885 some 10,000 h.p. was utilised.

In the following year a charter was obtained from the New York Legislature permitting sufficient water to be taken from the upper river to develop 200,000 h.p., and later the Canadian Government granted a concession allowing water for

How the Water is Harnessed

To describe the plant of the various power companies would take up a great deal of space and would become monotonous, and therefore we will be content to give an outline of the plant of the Niagara Falls Power Company. Leading from the river about a mile above the Falls is the power canal, on each side of which are situated the company's power-houses.

The difference of level between the upper river and the rapids below the falls is 200 ft. Beneath each power-house are several deep wells called "penstocks," which draw water from the canal and allow it to fall 180 ft. on to huge water turbines. After exerting its mighty power in passing through the turbines the water flows away along a tunnel, which empties itself below the Falls. This tunnel is about 7,000 ft. in length, and its construction occupied 1,000 men continuously for over three years, during which time 300,000 tons of rock were removed and 160,000 bricks were used to form the lining. The swiftly-turning turbines drive long vertical shafts, which in turn drive the moving parts of the electric generators at the surface of the ground. These generators are huge alternating current dynamos, in which the armature is fixed and the field magnets revolve outside it. The field-rings are mounted on the top ends of the shafts, the total weight of the two being about 35 tons. Shafts and rings revolve at the rate of 250 revolutions per minute.

Transmission of Power

Part of the enormous power generated at Niagara is used in the great industrial enterprises situated in the immediate vicinity of the Falls. The remainder is transmitted a great distance, the current being "stepped-up" to obtain economy in transmission, in the manner described in the article on Power Stations in last month's "M.M." Raised to a pressure of 60,000 volts the current is transmitted to cities as far distant as 160 miles, while at a voltage almost twice as great electrical energy is supplied to areas within a radius of 250 miles. By means of yet higher pressures, say 220,000

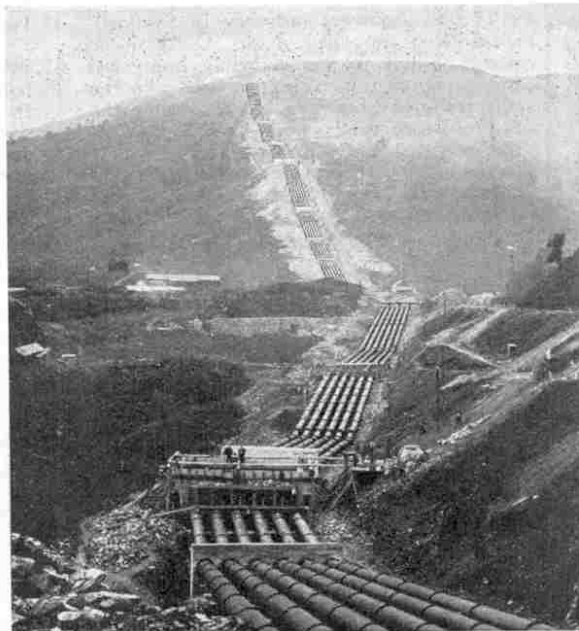

Photo courtesy]

[Messrs. Glenfield & Kennedy

The enormous and lengthy pipe-lines at Loch Leven

The fall is here 950 ft., giving a pressure, at the turbines, of 400 lb. per square inch

250,000 h.p. to be drawn from the Canadian side of the falls. These concessions were obtained by a company now known as the Niagara Falls Power Company. Since then the Ontario Power Company and other great companies have established themselves at Niagara, and to-day about three-quarters of a million horse-power is drawn from the Falls.

volts, power from Niagara could be made to light the streets of New York.

Further schemes of development at Niagara are under consideration, among them being a proposal to dam the river about five miles above the Falls, thereby making available an estimated addition of 2,000,000 h.p. This increase of power would, it is calculated, provide half the electric power needed by the whole State of New York.

Modern Water Turbines

We have already mentioned the great water turbines used in the power plant at Niagara. These turbines are the successors of the old-fashioned water-wheels, but their efficiency is considerably greater. They may be divided into two main classes, (a) pressure or reaction turbines and (b) impulse turbines.

In the reaction turbine the water enters the wheel through fixed guide passages. These passages are so curved as to give the water a certain velocity in the direction of motion of the wheel. Entering the wheel of the turbine, the water flows along past curved vanes to which it imparts its energy and finally it passes out in such a direction that it has no further momentum in the direction of the wheel's motion.

In the impulse turbine the water is brought along a pipe-line under pressure and forms a jet moving at a very high velocity. This jet is directed on to a "runner" carrying some kind of buckets. Our illustration shows the runner of a 15,000 h.p. impulse turbine, which consists of a cast steel disc carrying 24 buckets. The complete runner weighs over 10 tons and each bucket weighs 375 lbs. The buckets, which are highly polished in order to reduce losses through friction, are attached to the disc by means of a specially-designed fastening. This fastening has to withstand two powerful and totally different forces—the continuous centrifugal force of the buckets themselves, and the impulse of a 30-ton jet of water occurring 300 times every minute.

Turbines of one or other of these types are used in all hydro-electric power plants, the choice of the particular type being decided by the height of the fall and other local circumstances.

Biggest Dam in the World

So much has been written about the production of electric power at Niagara that there is a danger of our overlooking the importance of other developments in the United States, many of which are on a vast scale. A particularly interesting project is that at Muscle Shoals in the State of Alabama. Muscle Shoals is a shallow stretch of the Tennessee River in which, in a distance of 37 miles, the river has a fall of 130 ft., making possible the development of a million horse-power.

When America came into the Great War it was realised that immediate steps would have to be taken to supply an enormously-increased quantity of explosives. Surveys of Muscle Shoals had previously been made, and the Government at once granted funds for the building of a great dam across the Tennessee River and the construction of hydro-electric plant on a gigantic scale. A dam was necessary on account of the shallowness and the small fall of the river, and also

utilise the water of the San Joaquin and its tributaries. The idea originated as far back as 1883, but serious development was not begun until 1911, when it was realised that something must be done to meet the growing demand for electrical power in Los Angeles.

Highest Voltage yet Used

The construction of dams was commenced in 1912 and the first power-house was erected in the same year. To-day there are four power-houses in operation and development is still proceeding. Other dams are planned, and in a few years there will be a chain of great power-houses unequalled anywhere else in the world. Current is transmitted from this centre to the suburbs of Los Angeles, a distance of 270 miles, at the enormous pressure of 220,000 volts, which is the highest voltage yet used for commercial purposes.

At Great Falls on the Missouri River in Montana another vast hydro-electric plant is in operation. The river drops 400 ft. in a distance of about eight miles, and the energy thus developed is transformed into electric current, which—transmitted at a pressure of 100,000 volts—is used to drive the giant locomotives operating on the 440-mile section of the electrified track on the Chicago, Milwaukee and St. Paul Railroad.

There are many great hydro-electric plants at work in various other parts of the United States, in Canada and in South America, and Australia, New Zealand and Africa are rapidly developing their water resources. Another of the great hydro-electric schemes of the future will undoubtedly

come into being in Rhodesia, where the Zambesi River has a potential capacity of 435,000 h.p.!

Development in India

An interesting development is in progress in India in an area lying some 40 or 50 miles south-east of Bombay. This area embraces the Western Ghats mountains and a number of lakes situated in the upper valleys of the range. Here the Tata Hydro-Electric Supply Company already have in operation one large power station, which is being extended to a capacity of 90,000 h.p. Another power station, having a planned capacity of 60,000 h.p., is practically completed.

The latest and largest scheme will provide for the supply from a third power station of some 100,000 h.p. for industrial, tramway, and railway purposes in Bombay. For this undertaking a masonry dam 150 ft. high and 4,000 ft. long is under construction, which will result in the formation of a lake 16 square miles in area. To convey the water through the mountains a tunnel 14,300 ft. long and 120 square ft. in section is being constructed and this will deliver the water to

(Continued on page 294)

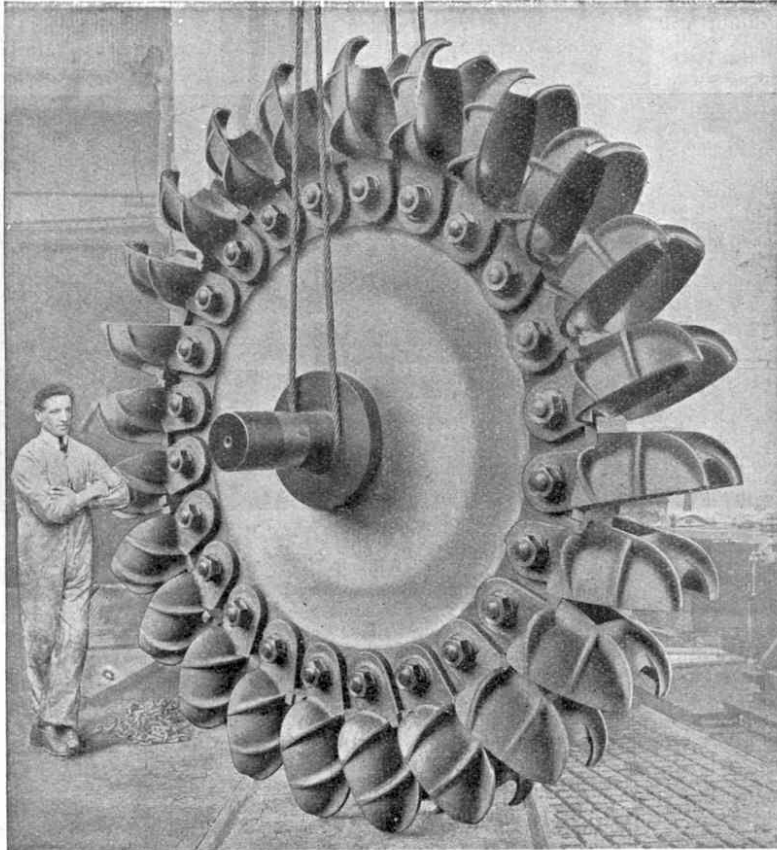

Photo courtesy]

[Messrs. English Electric Co. Ltd.

A Runner, with single-bolt Bucket attachment

because the amount of water in the river varies very greatly in different seasons of the year. Consequently the huge Wilson Dam was commenced. This dam was not finished when the war came to an end, and its progress was temporarily checked, but its completion in the near future is assured and it will then be the largest dam in the world. A mile in length and 137 ft. in height, it will contain a million cubic feet of concrete—sufficient to make a path 18 inches wide and 1½ inches thick round the whole earth! The dam will have a power capacity of 600,000 h.p., and in addition to this its construction will have the effect of making the river navigable for almost its whole length.

Huge Scheme in California

Another colossal American hydro-electric project is that in the San Joaquin Valley in California. When the contemplated works here are completed, which probably will be in about 10 years' time, it is estimated that over 1,400,000 h.p. of electrical energy will be available, equal to the electrical requirements of more than 5,000,000 people. The scheme comprises reservoirs, tunnels and power stations located so as to impound and

Further Adventures in Meccanoland

II. BRAINS AND INGENUITY IN THE CHAMPIONSHIP CONTEST

by "Spanner"

BEFORE passing on to other types of models submitted by competitors I want to illustrate two further humorous examples of a type of model that most of my readers no doubt will find interesting.

The first is a Gondola, entered by G. W. Healy, of London. This model is quite nicely proportioned, and Master Healy tells us that the gondolier actually rows when the gondola is pushed along the floor. This is very interesting and ingenious, of course, but at the same time I do not think that this competitor has made quite the most of his model. For one thing its general appearance gives the impression of flimsiness, and further, the designer has omitted the cabin in the centre of the boat, which is a characteristic feature of all gondolas intended to carry passengers. I feel sure that some of my readers could improve on this model and, no doubt, Master Healy himself could carry his own design a little further.

While looking at this model I recalled the recent statement made in a number of newspapers that the rowing gondola on the canals of Venice is doomed, and that within the next eighteen months every gondola must be fitted with an

that the wash from the comparatively small number of motor boats at present running is damaging the water-fronts of some of the ancient Venetian buildings. The general introduction of motor power would certainly speed up traffic in Venice,

even goes as far as to suggest that Meccano Ltd. should feature humorous models a little more strongly, on the ground that such models would appeal to the younger Meccano boys. I think it is quite probable that Master Manning is not very far wrong in this idea.

I was rather surprised to find that such a large number of competitors had tried their hands at designing sailing ships and steamers, and I was struck by the pleasing results obtained. I have only space to illustrate one example of this type—an interesting model of a steamer sent in by J. Ruwet, of Liege. The designing and building of this model must have called for a great deal of thought and ingenuity, and the result is certainly quite successful. The model evidently follows the lines of Continental-built steamers, and I have no doubt that many of my readers could design a

vessel that would resemble more closely the production of our own shipyards.

With reference to marine designs I may mention in passing that there appears to be a great deal of scope in models of various types of Dredgers, Fire-Boats and such like vessels, in addition to Repair Ships carrying cranes and similar appliances.

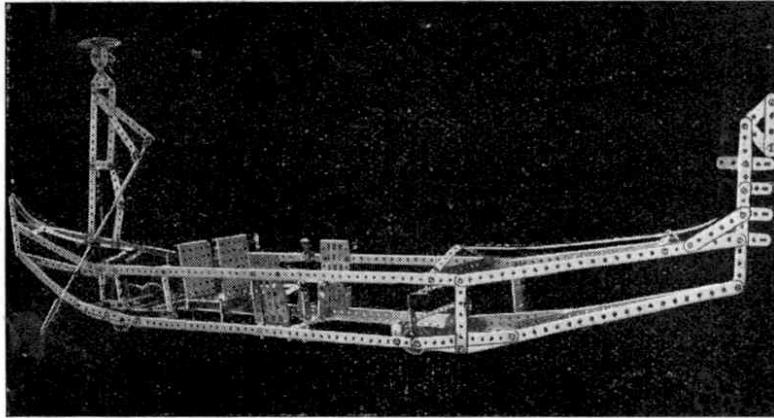

Gondola

(Entered by G. W. Healy, London)

but all those who have visited this wonderful city will feel regret at the thought of the disappearance of the picturesque gondolier.

Another model on humorous lines is "The Twins on a Swinging Boat," submitted by M. Manning, of Bristol. I have already given one example of the work of this competitor, who appears to have a strong leaning towards models of this kind, and certainly he possesses considerable skill in designing them. He

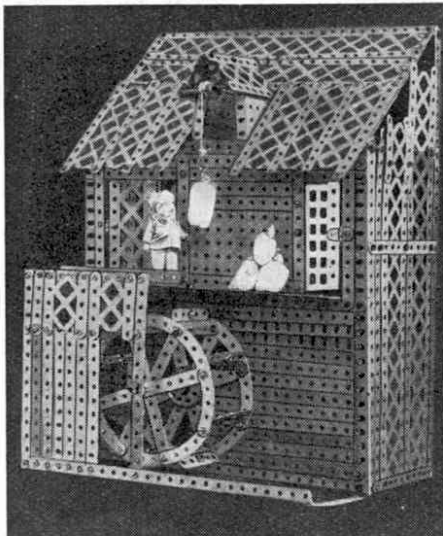

Water-Mill

(Entered by M. Michel, of Havre)

electric motor. It is difficult to believe that this is really the decision of the Venetian authorities, and I should have thought that they would be much more likely to prohibit motor gondolas altogether. Motor boats moving swiftly along narrow canals inevitably raise a considerable amount of wash, and I believe that there have already been complaints

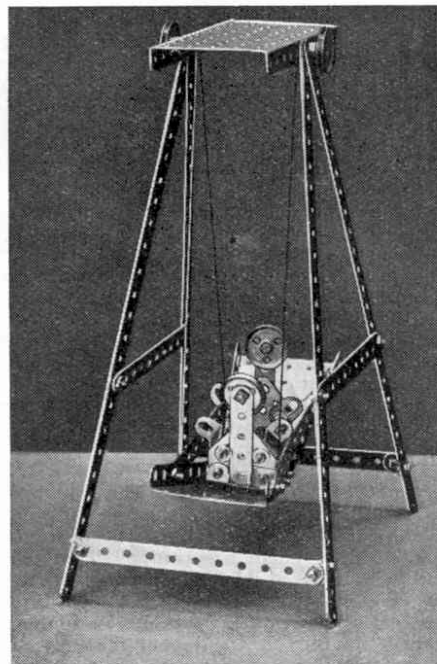

The Meccano Twins on a Swing Boat
(Entered by M. Manning, Bristol)

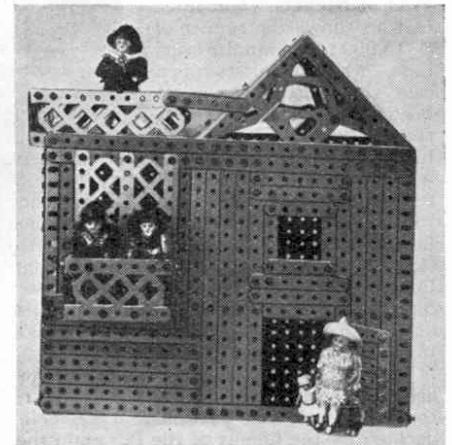

The Meccano House

(Entered by J. R. P. Yraolo, of Buenos Aires)

While I was enjoying myself among the humorous entries I came across two or three models that struck a really tragic note. One of these was a model of an old-time gibbet on which our forefathers used to hang malefactors for even such small offences as stealing a sheep! One or two Meccano boys in France sent in models of a guillotine which, as we all know, is the apparatus used for cutting off the heads of criminals who are sentenced to death in that country, our method of

hanging apparently not being considered good enough!

Mention of the name "guillotine" brings up memories of the tragic times of the French Revolution, when the French Communists sent so many of their fellow-countrymen to death. This unpleasant instrument was officially introduced into France in 1792 as the means of inflicting capital punishment. It was named after the man who was believed to be its inventor, Dr. Joseph Guillotin. I am able to illustrate one of these models submitted by Rene Lafette, of Belfort, who states that, both in shape and in method of operation, it closely resembles a real guillotine. It certainly is a sinister-looking object, and its effectiveness might be further added to by using a safety-razor blade as the knife, in which case perhaps

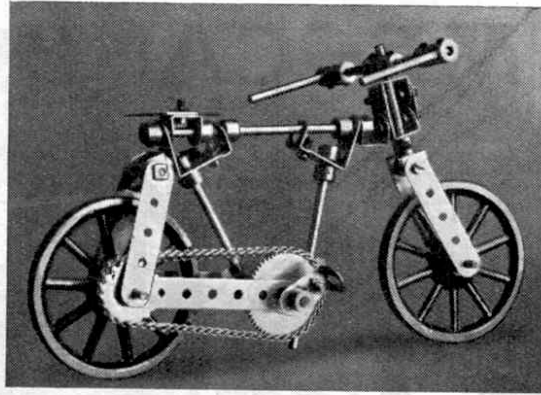

A Meccano Bicycle

(Entered by F. E. Salom, of Barcelona)

As far as I am concerned I should always handle the model with the greatest care for fear of getting my finger in the wrong place!

It is rather interesting to remember that there is another form of guillotine that is employed for much more pleasant purposes. This is the machine used by printers and bookbinders for cutting paper and trimming the edges of books after the sheets have been sewn together. This machine is similar in general construction to its gruesome big brother.

Another model from France is one sent in by Pierre Boudier, of Rouen, which is named a "Persian Roulette." You know, of course, that roulette is a gambling game, and apparently the big wheel with the numbers on it is spun round rapidly and the person whose number stops at the vertical pointer is the winner. Along with his entry the inventor enclosed a cutting from a Rouen newspaper, containing an account of a

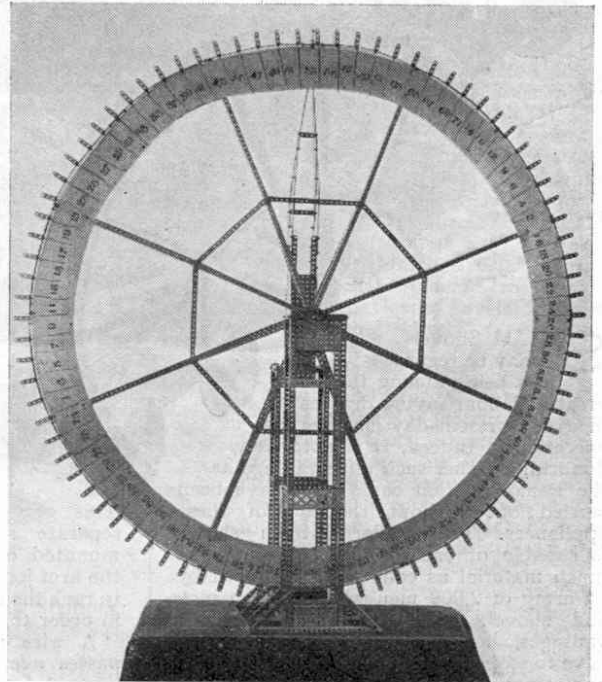

Persian Roulette

(Entered by Pierre Boudier, of Rouen)

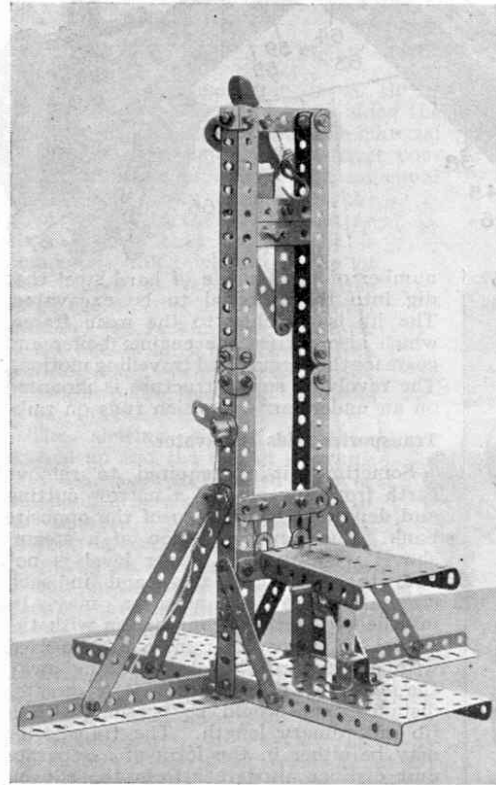

Guillotine

(Entered by Rene Lafette, of Belfort)

somebody's dolls would make good subjects (or objects) for decapitation!

juvenile ball that was held recently at the Hotel de France, Rouen, where his model

was used for distributing prizes. For the benefit of my readers, most of whom undoubtedly study French at school, I give the following extract from the newspaper:—" Une Loterie fit des heureux; les lots étaient de qualité; ils avaient été offerts par les commercants rouennais. Et le jeu de la roulette persane, édifié grâce a l'ingéniosité étonnante de M. Pierre Boudier, seulement âgé de 14 ans, fonctionna à merveille."

I noticed that many of the entrants in

of fun to be had from models of this kind, and I should very much like to see the idea further developed.

(Continued on page 294)

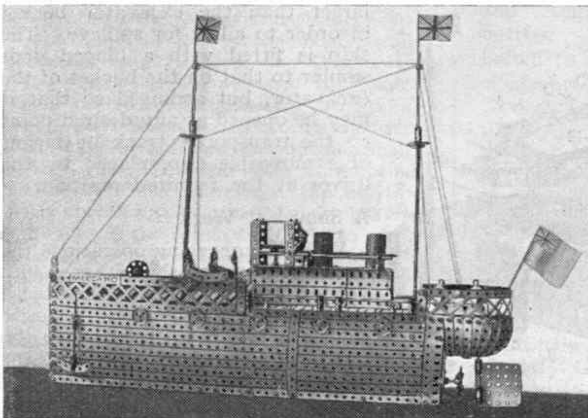

Meccano Steamer

(Entered by J. Ruwet, of Liege)

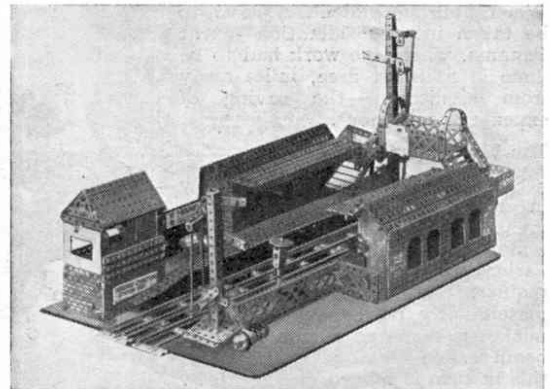

Railway Station

(Entered by D. Crankshaw, of Nelson)

A NEW MECCANO MODEL

Model No. 707 Steam Shovel

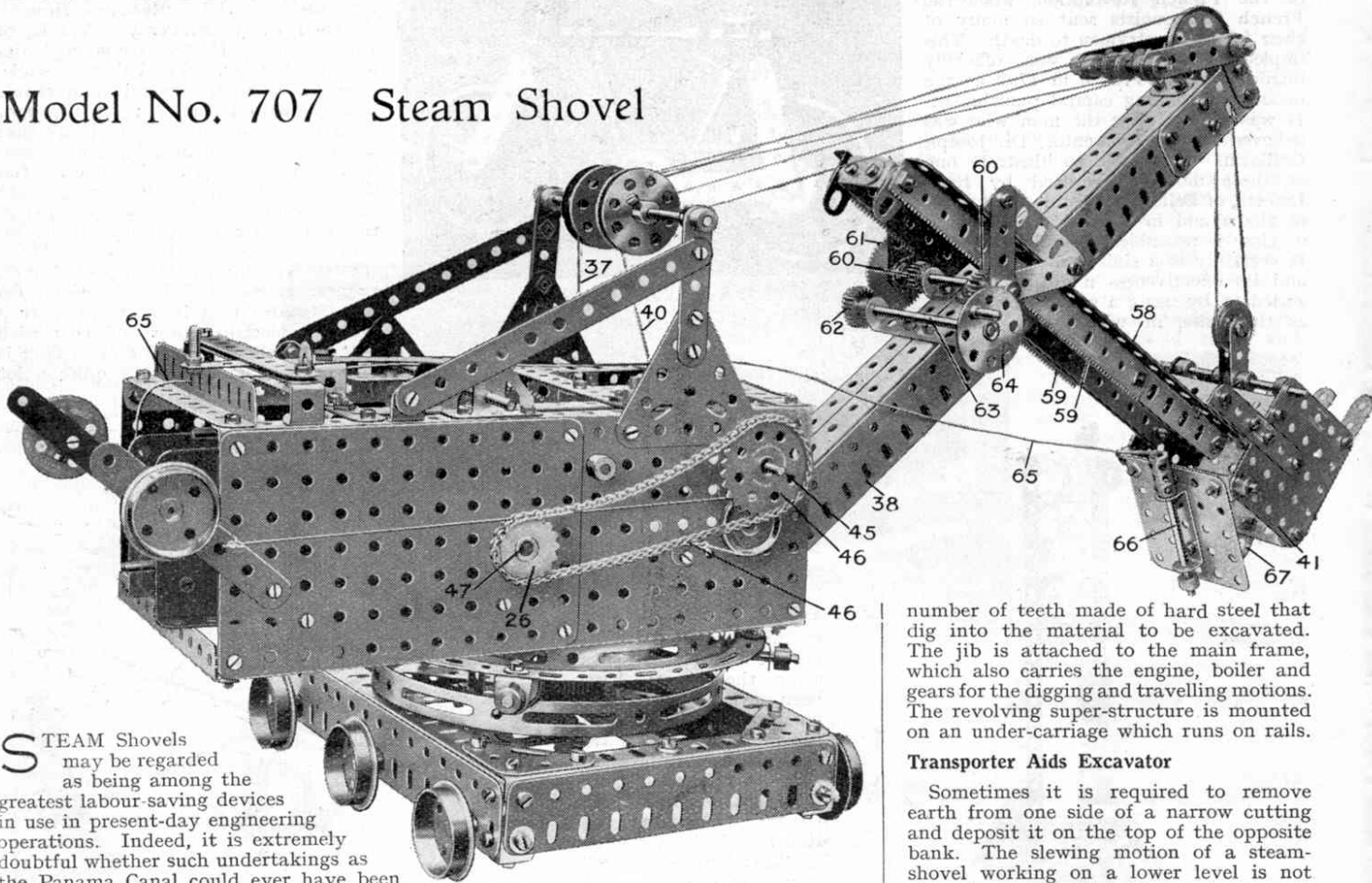

STEAM Shovels may be regarded as being among the greatest labour-saving devices in use in present-day engineering operations. Indeed, it is extremely doubtful whether such undertakings as the Panama Canal could ever have been carried out without the aid of these appliances. The modern steam shovel is capable of excavating in one day as much material as could be dealt with by an army of 2,000 men working with pick and shovel. One of its greatest advantages, however, is that it does not have to stop for meals or to rest. It works unceasingly from morning to night, never relaxing its output, and during this time requires only about three men to attend to it. Some idea of the vast amount of work that these machines can get through may be gained by considering the fact that the eighty steam shovels employed in the construction of the Panama Canal were the equivalent of 160,000 men! When housing difficulties have to be taken into consideration—as at Panama, where the work had to be done in a desert area, miles away from civilisation—the saving of expense is enormous.

The Mechanism

Steam shovels are used chiefly in engineering operations in which great quantities of earth have to be removed. They are constructed in various sizes, according to the output required and the nature of the material to be excavated. The bucket is mounted at the end of a beam called the bucket arm, and this in turn is moved on the jib by long racks meshing with gear wheels.

This gearing is generally driven by a separate set of self-contained engines, mounted on the jib at the point where the arm joins it, and this makes it possible to rack the bucket arm in or out as desired, in order to vary the working radius.

A wire rope attached to the bucket passes over a pulley at the top of the jib and from there to the winding drum, the arrangement being similar to that in a crane. When the gear is thrown in, the drum winds and the bucket is drawn upward, pivoting at the point at which the bucket arm is fixed to the jib. One edge of the bucket is fitted with a cutting edge known as the "lip," and this has a

number of teeth made of hard steel that dig into the material to be excavated. The jib is attached to the main frame, which also carries the engine, boiler and gears for the digging and travelling motions. The revolving super-structure is mounted on an under-carriage which runs on rails.

Transporter Aids Excavator

Sometimes it is required to remove earth from one side of a narrow cutting and deposit it on the top of the opposite bank. The slewing motion of a steam-shovel working on a lower level is not able to accomplish this, and in such circumstances a transporter may be installed to work in conjunction with the shovel. A transporter may also be used with a standard shovel for taking away the excavated material to a greater distance than would be possible with a jib of ordinary length. The transporter may be either in the form of a separate unit distinct altogether from the shovel, or it may consist of a framework attached to the shovel and worked by the main engines.

In both types the earth to be dumped is run up the inclined track of the transporter in a skip, which is made slightly larger than the excavator bucket in order to allow for spillage. The skip is fitted with a hinged door similar to that on the bucket of the excavator, but arranged so that it may be opened at any desired point on the transporter track by means of a moveable trip, placed by the driver at the required position.

A Shovel at Work

When commencing operations the bucket of a steam shovel hangs in a vertical position with the teeth resting on the ground opposite the face of the material to be removed. The driver starts up the engines and throws in the hoisting clutch, and this action drags the bucket forward and upward to the

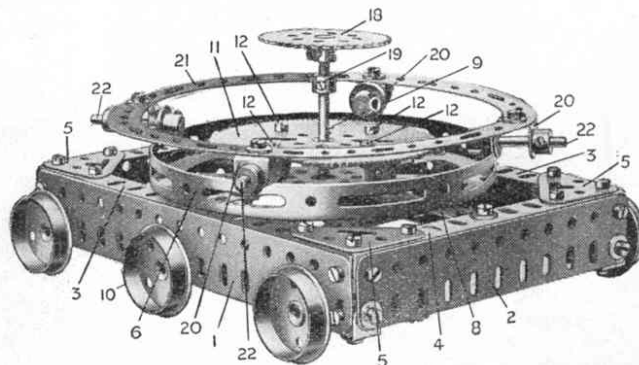

Fig. A

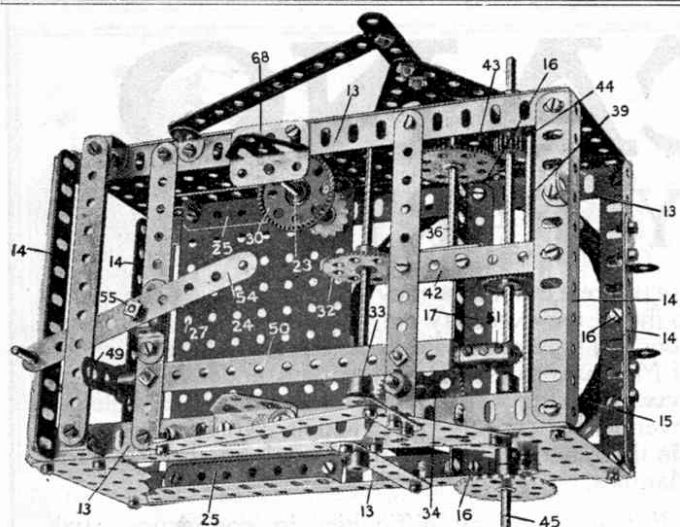

Fig. B

face. At the same time it is thrust outward by means of the racks along the bucket arm until it cuts away the material to the required depth. The driver controls the depth of cut so that an equal thickness is taken throughout the whole length of the stroke, and he thus ensures that the bucket is completely filled when the top of the stroke is reached. At this stage the hoisting clutch is thrown out and the racking motion draws in the bucket until it is clear of the working face, being held in the meantime on the free drum by means of the brake.

The slewing motion is then started up and the bucket is swung over the wagon to be filled, or over the point where the material is to be dumped. When the correct position is reached the driver pulls a cord by his side and so withdraws a catch on the bucket door, thereby allowing the contents of the bucket to be discharged. The slewing motion is then reversed and the bucket is swung back into position to take the next cut from the working face. These operations take place very quickly, and the whole series, or "cycle" as it is called, is performed in from 20 to 60 seconds, the actual time depending upon the size of the machine and the length of the jib.

From Bucket to Tipping Point

When a separate transporter is employed the shovel takes a cut and discharges the material into the skip which stands ready at the foot of the transporter track. When the skip is filled, the transporter driver starts his engines and the loaded skip is hauled up its track to the tipping point. Here the catch holding the door of the skip is knocked out automatically by trip gear, and the skip is emptied. The driver then throws out the hoisting clutch and the skip is lowered by gravity to the foot of the track, the drum to which its hauling rope is attached being allowed to run free, but controlled by the driver with a brake.

An excavator working with a separate transporter is capable of a larger output than a long-jib shovel of equal bucket capacity, largely because the machine has a shorter jib and therefore is able to slew round more quickly. Also it is found

that the coal consumption of the two separate machines is slightly less than that of a single long-jib machine, because the latter is very much heavier and requires more power to work it. The only disadvantages of any importance are that an extra man is required to work the transporter and that tracks must be laid for two machines instead of one.

The Meccano Model

This new Meccano model of a Steam Shovel is an excellent representation of a typical machine. The bucket is fitted with a collapsible bottom and the bucket arm is mounted separately on the jib, its position thereon being controlled by rack and pinion, actuated by hand-wheel. The model includes several interesting features, including a

roller race, in which the circular strip (a new part, No. 145) is used.

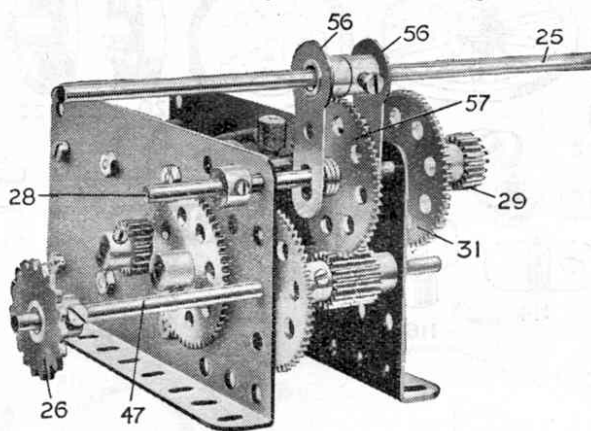

Fig. C

roller-race, in which the circular strip (a new part, No. 145) is used.

Constructing the Model

Begin by building up the base frame (Fig. A) from 7 1/2" Flat Girders (1) at the sides, and 5 1/2" Flat Girders (2) at the front. These are joined to 7 1/2" and 5 1/2" Angle Girders (3 and 4 respectively) braced with Corner Brackets (5) at the top, and Angle Brackets at the bottom. A Hub Disc (6) is bolted to a 7 1/2" Strip (8), which is secured across the Angle Girders and also bolted to two side Angle Girders (3). The vertical 4 1/2" Rod (9) is then passed through the centre hole of the Strip (8), and beneath is secured a Bevel Wheel. This engages another Bevel Wheel on the axle, which carries the central travelling wheels (10) and is connected by Sprocket Wheels and Chain to the rear axle. The large 3 1/2" Gear Wheel (11) is then secured to the Hub Disc by four 1/2" Reversed Angle Brackets by Bolts (12).

Building the Body

The body (Fig. B) consists of two 5 1/2" x 3 1/2" Flat Plates, overlapped three holes to form each side. These are secured to 9 1/2" Angle Girders (13) along the upper and lower edges, and these are connected across by 5 1/2" Angle Girders (14). Beneath the body is bolted a Circular Girder (15) by bolts (16) across which, held by the same Bolts, is a 5 1/2" Angle Girder (17). Through this Angle Girder passes the Rod (9) carrying a 2" Sprocket Wheel (18). A Collar (19) engages above the Angle Girder Circular Strip* (17).

The Roller Race

Next build up the roller race (Fig. A) formed of four Double Brackets (20), bolted to a Circular Strip* (21). 1/2" Fast Pulleys are secured on 1 1/2" Rods (22), which are also secured with Collars on the outside. The whole is then placed on the top edge of the Hub Disc and the body is threaded on to the Rod (9) in the centre hole of the Angle Girder (17). After the Collar (19) is secured in position, the Sprocket Wheel (18) is bolted to the Rod (9).

The top bearing for the 3 1/2" Rod (23) is formed by a 1 1/2" Flat Girder, over which it is secured a Trunnion. A 3 1/2" x 5 1/2" Flat Plate (24) is secured to each side of the body by 3 1/2" Angle Girders (25) in the second hole up. This provides a bed to which the electric motor is secured. On the lower part of the Rod (23) is secured a 3/4" Sprocket Wheel from which a Chain drives the Sprocket Wheel (18) which operates the lower bevels to drive the travelling wheels.

The Power Unit

Now build up the motor unit, leaving off the Rod (25) and Sprocket (26). (The Gear Wheels and Rods are clearly seen in Fig. C). The motor is then secured to the plate (24), the correct position being found when the fourth hole from the back of the motor registers with hole (27) in the plate.

When the motor is in position, owing to the Rod (28) being slideable the Pinion (29) may be engaged with the Contrate Wheel (30) or the Gear Wheel (31) with the Gear Wheel (32). The spindle of the other Gear Wheel (32) carries

(Continued on page 309)

* This new Meccano part will be announced shortly

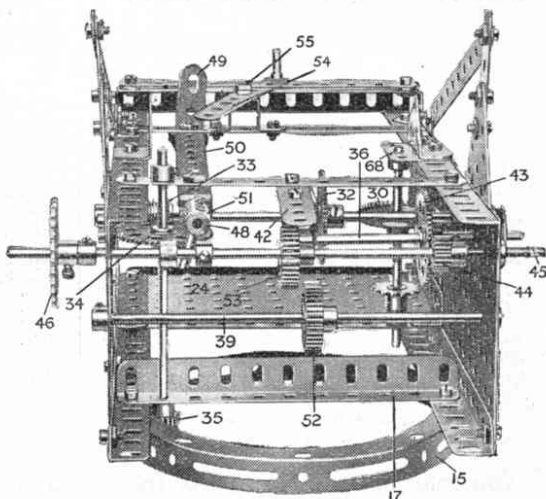

Fig. D

MECCANO

ACCESSORY PARTS

We illustrate below a selection of accessory parts that every Meccano boy will find useful for building the larger and more interesting models. Sometimes a model may be described in these pages that is beyond the capabilities of one of the smaller Outfits, but by purchasing a few extra parts, it becomes possible to build the model.

Then again, where it is not desired to purchase an Accessory Outfit in the first instance, an Outfit may be gradually converted into a higher Outfit by purchasing the necessary parts, from time to time.

Many of these parts have only recently been introduced, and although we know that they have a universal

use (were it otherwise they would not have been added to the system) we may not yet know all their applications. There are endless possibilities in the application of Meccano parts, and brainy boys endeavour to find new applications for them, and they make possible the invention of entirely new models, which gives more fun than merely copying the models in the Meccano Manuals.

If you have any difficulties in connection with using these parts, or any suggestions for new parts not already in the system, write to Meccano Ltd., Binns Road, Liverpool, and mark your envelope "Bright Ideas."

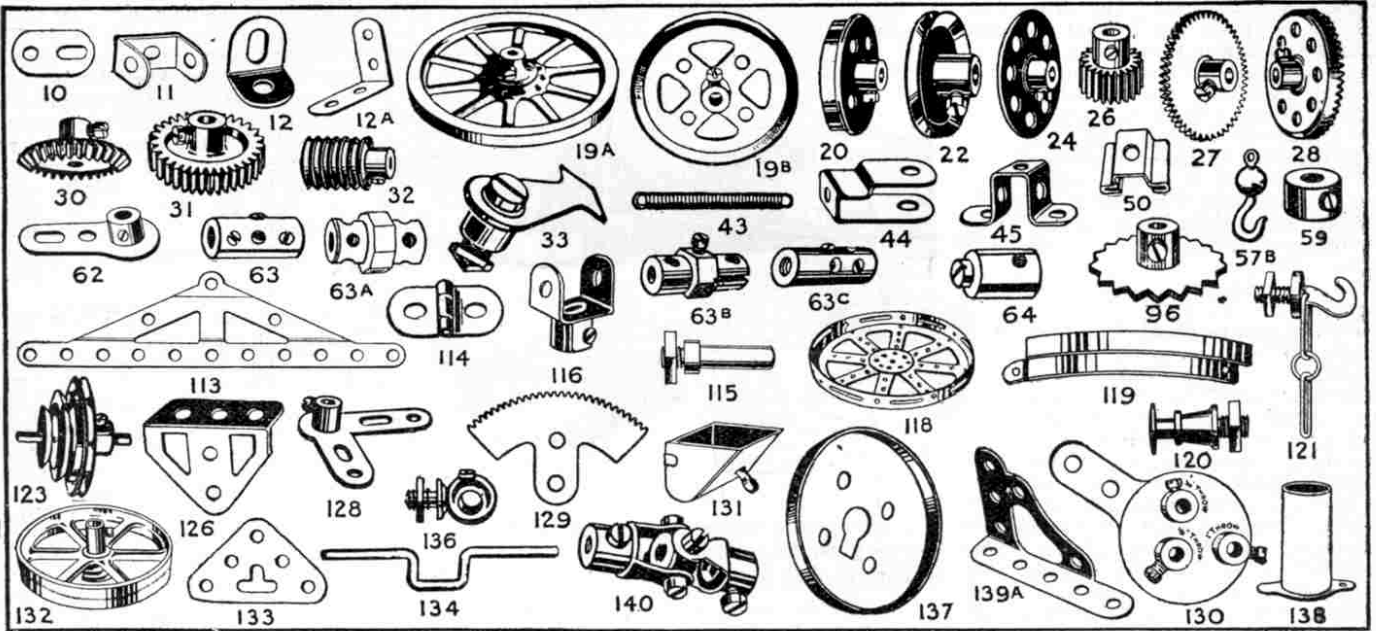

No.	Description	Quantity	s.	d.
10.	Flat Brackets	... 1/2 doz.	0	2
11.	Double Brackets	... each	0	1
12.	Angle Brackets, 1/2" x 1/2"	... doz.	0	6
12A.	" " 1" x 1/2"	... each	0	1
12B.	" " 1" x 1"	... each	0	1
19A.	Wheels, 3" diam. with set screws	... "	0	8
20.	Flanged Wheels	... "	0	6
Pulley Wheels:				
19B.	3" dia. with centre boss and set screw	each	0	8
19C.	6" " " " " " " "	"	2	6
20A.	2" " " " " " " "	"	0	6
21.	1 1/2" " " " " " " "	"	0	4
25A.	1" " " " " " " "	"	0	2
22A.	1/2" " without " " " " "	"	0	2
23.	1/2" " " " " " " "	"	0	6
24.	Bush Wheels	... "	0	4
25.	Pinion Wheels, 3/4" diam.	... "	0	6
26.	7" Gear Wheels, 50 teeth	... "	0	9
27A.	57 " " " " " " " "	... "	0	9
28.	Contrate Wheels, 1 1/2" diam.	... "	0	9
29.	" " " " " " " "	... "	0	6
30.	Bevel Gears	... "	0	10
31.	Gear Wheels, 1", 38 teeth	... "	1	0
32.	Worm Wheels	... "	0	6
33.	Pawls (complete)	... "	0	4
33A.	Pivot Bolts with Nuts	... "	0	2
43.	Springs	... "	0	2

No.	Description	Quantity	s.	d.
44.	Cranked Bent Strips	... each	0	1
45.	Double Bent Strips	... "	0	1
50.	Eye Pieces	... "	0	2
57.	Hooks	... "	0	1
57A.	" (scientific)	... "	0	1
57B.	" (loaded)	... "	0	5
58.	Spring Cord	... per length	0	9
59.	Collars with Set Screws	... each	0	2
62.	Cranks	... "	0	3
62A.	Threaded Cranks	... "	0	4
63.	Couplings	... "	0	6
63A.	Octagonal Couplings	... "	0	8
63B.	Strip Couplings	... "	0	8
63C.	Threaded Couplings	... "	0	6
64.	Threaded Bosses	... "	0	2
65.	Centre Forks	... "	0	2
84.	Sprocket Chain	... per length	0	6
85.	Sprocket Wheels, 2" diam.	... each	0	5
85A.	" " 1 1/2" " " " "	... "	0	4
85B.	" " 3" " " " "	... "	0	6
96.	" " 1" " " " "	... "	0	3
96A.	" " 1/2" " " " "	... "	0	3
109.	Face Plates, 2 1/2" diam.	... "	0	4
113.	Girder Frames	... "	0	2
114.	Hinges	... per pair	0	4
115.	Threaded Pins	... each	0	2
116.	Fork Pieces	... "	0	3
117.	Steel Balls, 1/4" diam.	... doz.	0	6

No.	Description	Quantity	s.	d.
118.	Hub Discs (5 1/2" diam.)	... each	1	3
119.	Channel Segments (8 to circle, 1 1/4" diam.)	... "	0	4
120.	Buffers	... "	0	2
120A.	Spring Buffers	... per pair	0	8
121.	Train Couplings	... each	0	4
122.	Miniature Loaded Sacks	... "	0	2
123.	Cone Pulleys	... "	1	3
126.	Trunnions	... "	0	3
126A.	Flat Trunnions	... "	0	2
127.	Simple Bell Cranks	... "	0	3
128.	Boss Bell Cranks	... "	0	4
129.	Rack Segments, 3" diam.	... "	0	6
130.	Triple Throw Eccentrics	... "	1	3
131.	Dredger Buckets	... "	0	2
132.	Flywheels, 2 3/4" diam.	... "	2	3
133.	Corner Brackets	... "	0	3
134.	Crank Shafts, 1" stroke	... "	0	3
136.	Handrail Supports	... "	0	3
137.	Wheel Flanges	... "	0	4
138.	Ship's Funnels	... "	0	4
139.	Flanged Brackets, right	... "	0	2
139A.	" left	... "	0	2
140.	Universal Couplings	... "	0	9
141.	Wire Lines (for suspending clock weights)	... "	0	9
142.	Rubber Rings	... "	0	4
143.	Circular Girders, 5 1/4" diam.	... "	1	0

You may obtain these parts from your dealer, or direct from MECCANO LTD., BINNS ROAD, LIVERPOOL.



(Continued)

ALTHOUGH I had been over two hours in the Palace of Industry, I did not feel a bit tired—that feeling didn't come over me until I got home (at well after midnight!). I suppose it was the excitement and wonder of it all that kept me "keyed-up." Continuing my tour of the chemical section I came to that part where they were making soap.

Now it is a common joke to suppose that we boys are not fond of soap, but I am sure every boy could not help but be interested in watching its manufacture on Messrs. Gibbs' stand. I was more particularly interested because I have often noticed Messrs. Gibbs' advertisement in the "M.M."

"Bonzo" in a New Rôle

First the various ingredients are placed in a huge funnel attached to a contrivance that is something like a large sausage-making machine. Then a very pleasant perfume is poured in and the whole is thoroughly stirred by machinery until it becomes a creamy mixture. It is then passed through to another machine in which it is compressed, and produced in a rounded strip looking for all the world like tooth-paste coming from its tube. This strip is cut into small pieces, the corners are cut off by girls, and the pieces placed in a small iron die. A lever is raised and dropped and a perfectly-moulded tablet of Cold Cream Soap, stamped with the makers' name, is the result! Each tablet is examined to see that it is smooth and perfect, and it is then passed on to be wrapped and packed in a dainty box.

There was such a lovely scent near this stand that I thought there must be a flower-garden round the corner. I found it came from a perfume stall where the attendants were spraying various perfumes to demonstrate their fragrance. I noticed our old friend "Bonzo" sitting on top of an alabaster bowl, and was much amused to find that he was holding a cleverly-concealed scent spray!

Needle-making

As time was quickly passing I hurried through the china section, where beautiful bowls and vases were displayed, and the household section where dozens of labour-saving devices were exhibited, until I came to where Messrs. Abel Morrel & Co. were exhibiting a needle machine that was in use nearly fifty years ago and which Queen Victoria had admired at a previous Exhibition. The machine was still working, and as I watched the eye being put into each needle separately I thought what a slow process it was, making needles by the old method. Turn-

ing round I saw a very different process in the modern needle-making machine, from which the needles were sliding by the hundreds every minute. I did not know until then that needles are made in pairs, points outward, and the eyes punched in the middle of the bars, the needles afterwards being separated.

Stocking-Weaving—the Old Way and the New

There was the whirr and rattle of machinery coming from the next avenue,



By permission]

[Editor of "Mersey"

Mr. Smith (watching the "Mammoth" Crane moving up the Mersey): "Look! Polly, at that ship taking that great Meccano Model to Wembley!"

so I wended my way to where a man was patiently weaving silk stockings on an old-type machine, consisting of a frame about 3 ft. in width. On this were strung strands of silk and the thread had to be started on its journey each time by hand before the shuttle took it across. The work is very trying for the eyes, especially as it is necessary to have a bright light near the work the whole time, and to ensure that the threads are run closely together. On this machine an expert weaver only makes one pair of stockings a day.

In contrast to this machine was a modern stocking loom, on which a dozen pairs of stockings are woven at once and attendants merely pass up and down to see that all is going well. It was wonderful to watch the numerous shuttles darting through, and then resting while a shuttle with another colour of silk took its turn. I

watched while about an inch of colour was woven, then a series of small steel bars slid along about an inch on the machine and at once all the shuttles with another colour came into action. In a few moments a wonderful pattern of squares and diamonds was formed before my eyes, with fancy stripes of grey, black and blue. When these stockings were finished I turned round and found that while these were being made, only a few inches of stocking had been woven by the lonely weaver on his little machine, and I could not help thinking that he must have felt disheartened when he saw how slowly his work progressed!

A Trip Around India

It was with great reluctance that I left the Palace of Industry, but as I felt I must see something of the other marvels of Wembley, there was nothing else for it but to move on to another building at once. I decided that the most imposing building in sight should be my next objective. This was the Indian Pavilion, which is built in exact imitation of the wonderful Indian Temple at Agra, the Taj Mahal. The courtyard, with its fountain playing and its swinging red lamps in each doorway, impressed me greatly, and at a distance the white plaster was a very close imitation of the marble Taj. Especially was this so when the sun shone on the dome and on the beautiful archways and pillars—indeed it gave me quite an "Arabian Nights" feeling, and I could almost imagine I was far away in India! As I climbed the steps, I came face to face with an Indian, who smiled to see the evident admiration with which I was regarding the building.

As I entered I was greeted by the fragrance of Indian perfumes and by the tinkling of little bells, and all around me were wonderful exhibits. There were magnificent cloth-of-gold and beautiful embroideries, used on ceremonial occasions by Indians of high rank. Rugs of soft texture and delicate shades, of such intricate patterns that a worker often requires a year to finish one rug! Models of temples made of mother-of-pearl and marvellously wrought silver; ivory carvings; brass-ware engraved by hand, some of it inscribed with passages from the Koran. Native furniture—tables and dainty chairs, bureaux and cabinets in different woods.

A Costly Casket

Many of these articles were elaborately inlaid with mother-of-pearl, and one cabinet was inlaid with ivory in most intricate patterns of ferns and

(Continued on page 289)

Brandes

The Name to Know in Radio

The Table-Talker strikes a "new note!"

DECIDED originality! Original in the real beauty of its performance, original in its ingenious construction, original in its remarkable price. The horn is so contrived that every note registered is encompassed and emitted with absolute purity—there is no discordant echo from its walls. The full-toned accuracy of reproduction is consistent with the mellow note which is the chief characteristic of the famous Brandes "Matched Tone" Headphones. No adjustment is required because the exact tone degree is there all the time. Simple lines and a neutral brown finish make it a tasteful and effective addition to your set.

Brandes products are obtainable from any reputable dealer and carry our official money-back guarantee, enabling you to return them within 10 days if dissatisfied.

Matched Tone
TRADE MARK
RADIO HEADPHONES 25/-

Table-Talker
TRADE MARK
42/-

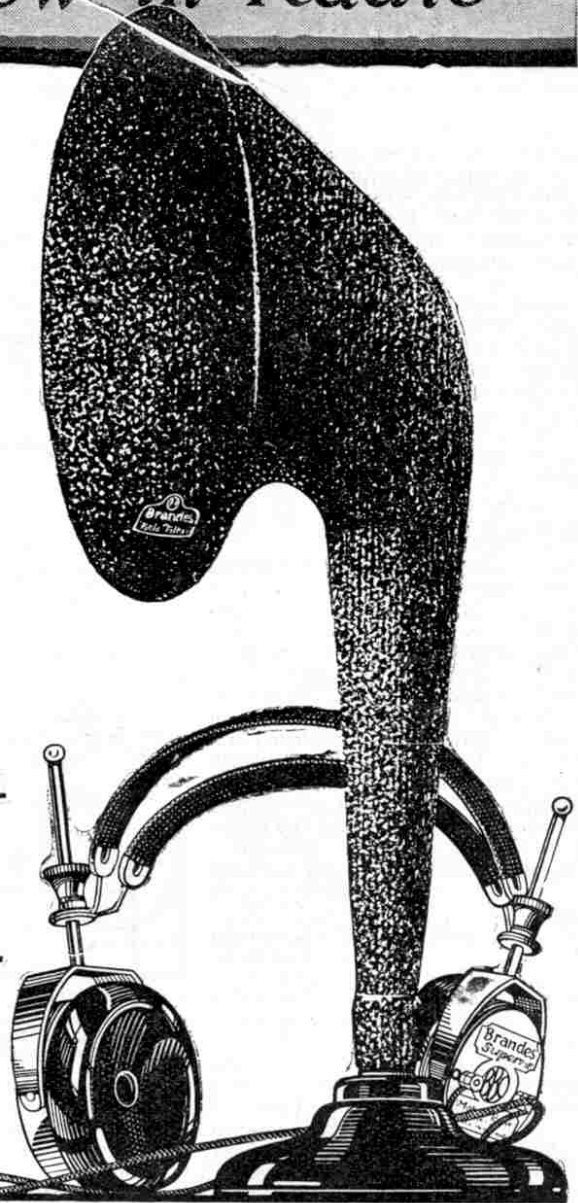

*Tune with Brandes "Matched Tone"
Radio Headphones
Then Listen with Brandes
Table Talker*

Wembley—(continued from page 287)

flowers, every inch being most elaborately carved. Figures of men and of animals, carved in ivory and ebony, were also displayed, and a huge ivory elephant, with gold tusks and trappings and ruby eyes, was being very much admired. Here, too, was a jewel-casket of ivory, richly carved and inlaid with precious stones, a beautiful piece of work, indeed, and carved from a single elephant tusk. It was for sale but I didn't buy it—the price was £400!

There were many little goddesses, who sat with their hands folded looking eternally happy. Some were gilded, and wore precious stones as crowns; others were carved in ivory, and had rings, bracelets, and crowns of rubies and pearls! Everywhere there was the scent of burning "joss-sticks"—scented wood that is burnt slowly as a tribute to native gods. I purchased a bundle of the thin long sticks, that look for all the world like thin coloured tapers, but I don't know what the family will think when I start burning them in my den!

The Story of Indian Transport

In the next section fascinating India had vanished, as also had its perfumes and gems, giving place to the Indian State Railway exhibit. This consisted of a miniature Pullman car with every conceivable provision for passengers' comfort, including windows fitted with mosquito-nets and wooden shutters for use at night.

Cleverly-modelled scenes showed the difference that railways have made to the health and prosperity of India, commencing with the days when the natives lived in rough huts and used primitive instruments for cultivating the land, and when beasts of burden were the only known means of transport. The scenes showed the rough carts, drawn by two bullocks, which were used before the covered wagons, drawn by horses. The advent of the first railway was shown by a model of the first engine, a queer-looking thing, indeed, when compared with the "Flying Scotsman" and one or two of my other favourites! This primitive Indian loco had a contrivance on the chimney something like a huge funnel, and almost gave me the impression that the driver had been

filling up the boiler with petrol and left in the funnel by accident!

The models showed clearly how the railway made it possible to bring machinery from the seaport towns to the country, and also how it was possible to transport labour, so that farming conditions im-

It seems that on great feast days the Indians attend religious festivals, which occur fairly frequently—in fact there are about a dozen each year. On these occasions the people flock to the big cities and naturally the stations are crowded. Unfortunately many of the people are unable to read or write, and as may be

imagined, the booking clerks would have a very rough time under the ordinary system of issuing tickets! To surmount the difficulty the authorities have devised a very ingenious system. Upon stating their destination and paying their fare, the passengers are given tickets of different colours, each religious centre having a distinctive colour. Near to the platforms are large compounds or enclosures, at each of which a flag of distinctive colour is flown. The passengers enter the compound

that has a flag agreeing in colour with their ticket, and thus all the passengers for a particular city are in their correct compound, without the trouble of having to read any directions! It is then an easy matter for the gates of one compound to be opened when the train for their destination comes in. Despite the fact that thousands of these pilgrims travel in the course of a day, it is an almost unheard-of occurrence for one to enter a wrong train, which speaks well for the efficiency of this novel system!

Strange Marriage Customs

Whilst passing through one of the small halls connecting the different sections of the building, I came across an ancient manuscript, elaborately illuminated. I could not understand the original, of course, but beside it was an English translation, from which I discovered that the very lengthy parchment was an agreement of marriage between an Indian Prince and Princess of an ancient family of native rulers. The document was very old but well preserved, and it seemed strange to read of the Prince "graciously accepting the delicate person" of the Princess together with a tremendous dowry

of oxen, gems and other valuables. The virtues and beauty of the lady were lauded at great length, and the bravery, nobility and gallantry of her husband-to-be were similarly extolled! I remembered having read that the old Indian marriage

(Continued on page 315)



Photo by]

The Indian Pavilion

[Campbell Gray

In the foreground is seen the head of a moose at the door of the Canadian building.

proved and irrigation on a scientific basis became possible.

Handling Passengers who Cannot Read

My attention was next attracted by a huge model of a typical wayside station on the Oudh and Rohil Khand Railway

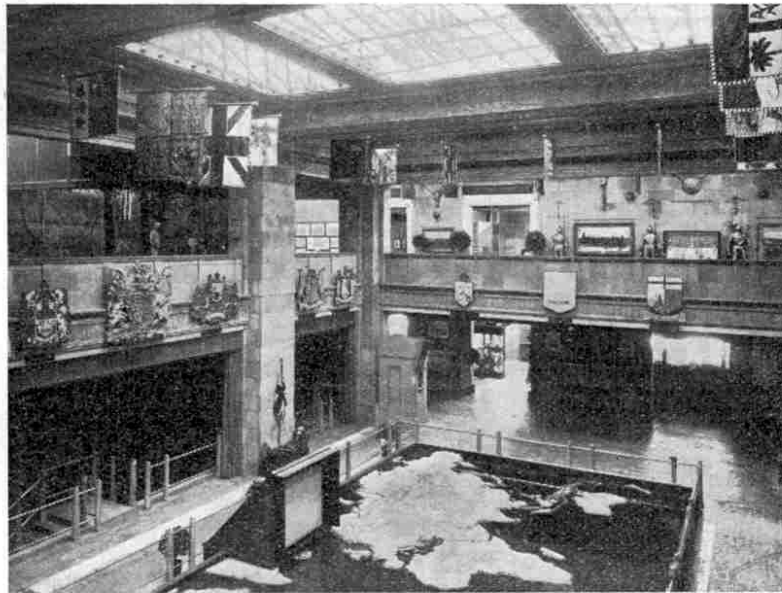

Photo by]

The Government Building

[Campbell Gray

The huge map is seen in the Hall, and on the Gallery, at the left, is the Science v. Disease Exhibit described in this article.

in India, its platforms thronged with tiny figures representing natives in gaily-coloured clothes. This exhibit was 36 ft. in length, 15 ft. in width, and nowhere during my tour did I see a more perfectly-proportioned model nor one more interesting.

REDUCTION IN PRICES OF HORNBY CLOCK WORK TRAINS

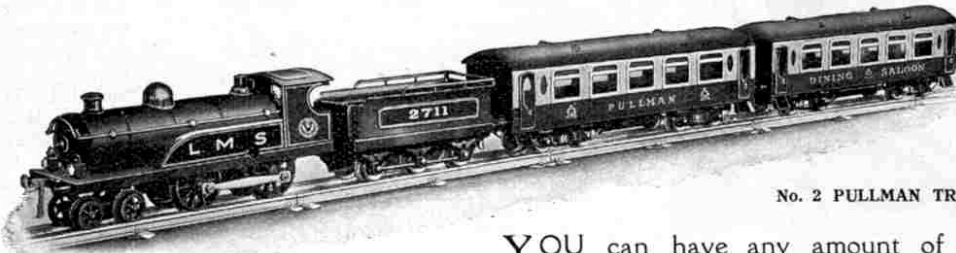

No. 2 PULLMAN TRAIN

Guarantee
Hornby and Zulu Trains are tested and their efficiency is guaranteed. A form of guarantee is furnished with each loco, and we undertake to repair, or replace at our option any loco that fails to run satisfactorily from any cause, other than misuse, within 60 days of purchase.

YOU can have any amount of fun with a Hornby Train. Shunting, coupling-up the rolling stock and making up trains will give you hours of pleasure. Hornby Trains are beautifully finished, strongly made, and will last for ever. One of their most valuable features is that all the parts are standardised, and any lost or damaged part may be replaced with a new one.

Every train is guaranteed, in accordance with the terms shown above, and you are therefore sure of satisfaction if you buy a Hornby.

A series of articles are now being published in these pages telling you how to get the most fun out of your Hornby Train set. You will enjoy reading them, and if you are not yet the proud possessor of a Hornby Train choose one for your next Birthday present—you will never regret it!



No. 1 PASSENGER TRAIN (new type coaches with opening doors)

HORNBY TRAIN PRICES

No. 1			
Goods Set	22/6	Wagons	each 2/6
Passenger Set	30/-	Tenders	2/6
Locos	each 15/-	Passenger Coaches	5/-
No. 2			
Goods Set	37/6	Wagons	each 3/6
No. 2 Pullman Set	60/-	Tenders	3/6
Locos	each 22/6	Pullman Cars	15/-

ZULU CLOCK WORK TRAINS



Zulu Passenger Set	22/6	Zulu Tenders	each 2/-
.. Goods	17/6	.. Coaches	4/-
.. Locos	each 10/6	.. Wagons	2/6

Full particulars of these splendid trains will be sent post free on request.

HORNBY TANK LOCOS



No. 1

The Hornby No. 1 Tank Loco is a strong and durable loco capable of any amount of hard work; richly enamelled and highly finished; fitted with reversing gear, brake and governor.

Gauge 0, in colours to represent L.M.S. or L.N.E.R. Companies' Locos 12/6



No. 2

The Hornby No. 2 Tank Loco is a powerful model embodying all the characteristics of the Hornby series. It is 11½" in length and is fitted at both ends with a four-wheeled bogey. Beautifully finished in colours; lettered L.M.S. or L.N.E.R., with reversing gear, brake and governor. Suitable for 2 ft. radius rails only.

Price 30/-

OBTAINABLE FROM ALL MECCANO DEALERS

How to Run a Miniature Railway System

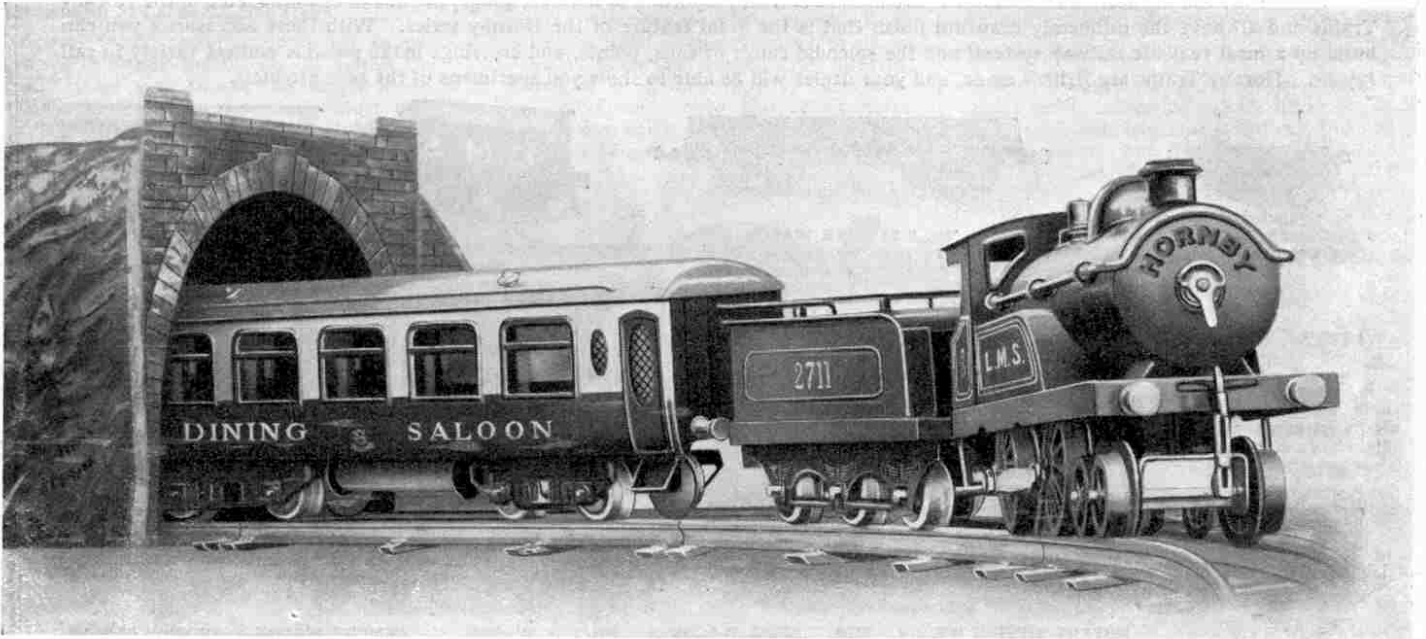

These articles, which have been specially written by an expert who has made a life-long study of miniature railways, are intended to show how to get the most fun out of a miniature railway system. A system built up on the lines described will not only be efficient in working and pleasing in appearance, but it will give untold hours of happiness and fun to its owner.

IN spite of the rival attractions of radio, motor-cars and aeroplanes, railways still maintain their fascination, and deep down in the heart of almost every boy there is a longing for a railway of his very own. But it must be a real railway, not just a rickety, foreign-made engine dragging a couple of absurd-looking carriages round and round a small circular track. It must be a correctly-laid-out railway with main line, branch lines and sidings, stations, tunnels and bridges, and fully equipped with points, crossings and signals. A real railway of this kind is easily built from the component parts of the Hornby Train System, and the object of this new series of articles is to show just how this can be done.

Unique Features of the System

The Hornby System has many unique features that place it in a category quite by itself. The clockwork motors are perfect pieces of mechanism with accurately-cut gears that ensure smooth and steady running, and the trains throughout are beautifully finished in every respect and are enamelled in the standard colours of the leading British railways.

Several train sets are available, each consisting of Loco, Tender, two Passenger Coaches or two Goods Wagons, and a set of rails including curves and straights. These train sets are only the foundation of the system, however, and exactly in the same way that the smallest Meccano Outfit may be converted into a No. 7 by the addition of Accessory Outfits, so a Hornby Train Set may be built up into a complete and elaborate railway system by the addition from time to time of various accessories. These accessories include a

great variety of Wagons, Bridges, Tunnels, Level Crossings, Signals and Signal Cabins, Water Tanks and all the essential features of a real railway. The track, too, is capable of almost infinite expansion, and the many different types of Points and Crossings enable any desired layout to be developed on sound railway principles.

It is well known that all the Meccano parts are carefully designed so as to take their appointed place in the complete system. Similarly each of the Hornby Train accessories is in perfect proportion to all the others. The result of this is that a layout built up entirely from Hornby Trains and accessories not only works perfectly, but also has a very attractive appearance on account of the symmetrical inter-relation of all its components.

Hornby Locos are Guaranteed

The great confidence of Meccano Ltd. in the perfect mechanism and workmanship of their locos is shown by the fact that they are guaranteed. Meccano Limited

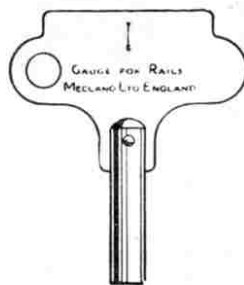

Fig. 1. The top of the Winding Key forms a Gauge for examining the track

will repair or replace, free of charge, any loco that fails to run satisfactorily from any cause other than misuse, within 60 days of the date of purchase.

Space Available

In contemplating the acquirement of a model railway the first point to be considered is the amount of space available. Some boys are fortunate in having at their disposal an attic or other spare room, where a large track may be laid and kept down more or less permanently. This arrangement is greatly to be preferred, but it is not all who are able to play under such ideal conditions; most boys have to make the best of the floor space of a living room, where the track has to be taken up after use and laid down afresh each time it is wanted. Of course, during the fine days of summer the track may be laid out of doors and great fun may be had in this way, but it is necessary for the rails to be taken indoors at night or they will rust badly, even if no rain falls, for the dew will quickly collect on them.

All Hornby Trains and Rails are gauge 0. In reference to railways the word gauge means the width of the track measured from inside to inside of the heads of the rails. Just as there is a standard gauge for full-sized railways—4 ft. 8½ ins. in Great Britain—so there are various standard gauges for miniature railways. Gauge 0 is the smallest of these standard gauges, and the width of the Hornby Rail is 1¾ in.

Although the whole of the Hornby track is thus the same width, it is made on different scales as regards curves. In the larger sets a complete circle made

(Continued on page 293)

New Rolling Stock and Accessories

(HORNBY SERIES)

There are now 50 different train accessories—Stations, Signal-boxes, Lamps, Wagons, Level-Crossings, Foot-Bridges, Turn-tables, etc. Further accessories will be added to the system from time to time, and will be announced in the pages of the "M.M."

All Hornby Rolling Stock and Accessories are built in correct proportion to the size, gauge, method of coupling, etc., of the Hornby Trains and all have the uniformly beautiful finish that is the great feature of the Hornby series. With these accessories you can build up a most realistic railway system, and the splendid range of rails, points, and crossings make possible endless variety in rail layout. Hornby Trains are British made, and your dealer will be able to show you specimens of the new products.



No. 1 LUMBER WAGON
Fitted with bolsters and stanchions for log transport.
Price 2/-



No. 2 LUMBER WAGON
Fitted with bolsters and stanchions for log transport. Suitable for 2 ft. radius rails only. Price 5/-



No. 1 LUGGAGE VAN
Representative colours.
Price 4/-



No. 2 LUGGAGE VAN
Finished in colour. Fitted with double doors. Suitable for 2 ft. radius rails only. Price 6/6



No. 1 TIMBER WAGON
Beautifully enamelled in colour and stoved. Price 2/-



No. 2 TIMBER WAGON
Beautifully enamelled in colour and stoved. Suitable for 2 ft. radius rails only. Price 4/6



No. 1 CATTLE TRUCK
Fitted with sliding door. Very realistic design. Price 4/-



No. 2 CATTLE TRUCK
Splendid model fitted with double doors. Suitable for 2 ft. radius rails only. Price 6/6



MILK TRAFFIC VAN
Fitted with sliding door, complete with milk cans. Price 4/6



ROTARY TIPPING WAGON
Finished in colour. Price 4/-



SIDE TIPPING WAGON
Excellent design and finish. Price 3/6



HOPPER WAGON
Mechanically unloaded. Finished in colour. Price 4/-



CEMENT WAGON
Finished in colour. Price 4/-



GUNPOWDER VAN
Finished in red. Price 4/-



BISCUIT VAN
Price 4/-



SECCOTINE VAN
Price 4/-



GAS CYLINDER WAGON
Finished in red, lettered gold. Price 3/-



PETROL TANK WAGON
Finished in colour. Price 3/-

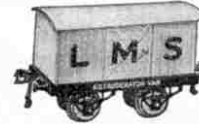

REFRIGERATOR VAN
Enamelled in white, lettered black. Price 4/-



SNOW PLOUGH
Finished in grey, with revolving cutter driven from front axle. Price 5/6



CRANE TRUCK
Working model. Finished in colours. Price 4/6

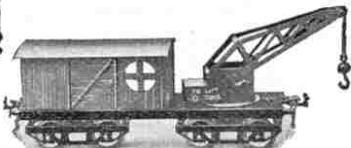

BREAKDOWN VAN AND CRANE
Excellent finish. Beautifully coloured. Suitable for 2 ft. radius rails only. Price 7/-



BRAKE VAN
Finished in colour. Price 4/-



TROLLEY WAGON. Finished in colour. Suitable for 2 ft. radius rails only. Price 6/-



GUARD'S VAN
Price 5/-



JUNCTION SIGNAL
Signal arms operated by levers at base. Very realistic model standing 14 in. in height. Price 5/6



SIGNAL CABIN
Dimensions: height 6½ in., width 3½ in., length 6½ in. Finished in colour and lettered "Windsor." Roof and back open to allow signal-levers to be fitted inside cabin if desired. Price 6/6



SIGNAL
Price 2/6

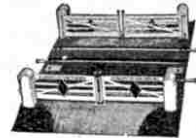

LEVEL CROSSING
Beautifully designed in colour. Measures 11½ in. x 7½ in., with Gauge 0 Rails in position. Price 6/6



FOOT-BRIDGE
No. 1. With detachable signals. Price 6/-
No. 2. Without signals. Price 3/6
Signals, per pair 2/9

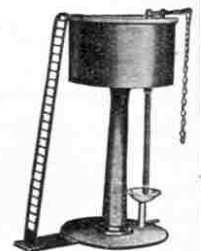

WATER TANK
Brightly coloured in red, yellow and black. 8½ in. in height, with flexible tube and pump lever. Price 6/6



PLATFORM ACCESSORIES No. 1 Price (per set) 2/-



PLATFORM ACCESSORIES No. 3 Price (per set) 2/-



PLATFORM ACCESSORIES No. 2 Price (per set) 2/-

ASK YOUR DEALER TO SHOW YOU SAMPLES

Miniature Railway System—(cont. from p. 291)

of the curved rails has a diameter of 4 ft., whereas in the smaller sets the circle is only 2 ft. in diameter. As the straight rails are exactly the same in both sets, it is clear that the amount of space occupied by any particular layout will depend upon the class of curved rails used.

Advantages of Large Radius Rails

Apart from considerations of space there is another matter to be borne in mind. If we wish to use the larger locomotives and rolling stock we must use curved rails of the larger radius. The reason for this is that, on account of their length of wheel-base, the larger vehicles cannot negotiate curves of the small radius rails. On the other hand, the smaller locomotives and rolling stock run even better on the large radius rails than on the small ones. Where they are so affected, the accessory points, etc., are made in both sizes, so that a layout may be made equally complete whichever radius of rails is used.

Before deciding upon which radius rails to use, all the points mentioned above should be carefully considered. If sufficient space is available, and particularly if the track can be laid down permanently in a spare room, there is no doubt about the superior advantages of the large radius rails, especially in permitting the use of the fine-looking No. 2 locomotives with bogies.

What to Buy

Having decided which rails are to be used, the next question is what to buy. Probably, most boys will buy one of the complete sets, each of which contains a Locomotive, Tender, either passenger Coaches or Goods Wagons, and a number of Rails. Then, when quite familiar with the working of this set, they will purchase the remaining pieces necessary to construct a complete railway layout as opportunity allows.

Laying the Track

Let us suppose we have purchased a complete set, either passenger or goods, and are now ready to set it to work. The first thing is to lay the track. The rails are fitted together by inserting the projecting peg at the end of one rail into the hollow railhead of the next. A very valuable feature of the Hornby Rails is the alternate pegs, the advantages of which will shortly become evident. It will be noticed that the sleepers carrying the rails are not flat, but are elevated at one end. The object of raising one rail of the track in this way will also be explained later, but in the meantime it should be noted that the rails must be fitted together so that all the sleepers slope in the same direction.

If the rails were merely pegged together, any movement of the track or an accidental knock would very likely cause two rails to

come apart. If this were to occur without being noticed at the time, a very realistic accident would result when the engine reached the gap! In order to make certain that the rails cannot come apart, ingenious locking clips are provided. The clip at the end of one rail fits into a slot in the end of the next, and in this manner the two rails are firmly attached together. It is perhaps a little trouble to fit in all these clips, but neglecting to do so will cause a great deal more trouble later on.

Provided that the track is laid carefully, the train should run along quite smoothly and easily. If it does not do so, there must be a defective place somewhere

may result in a broken spring. Another point to remember is that the key must be pressed well home and as far as it will go on the winding shaft. When the spring is run down the loco should not be pushed along the track by hand.

We now come to the operation of the locomotives, and in order to avoid the possibility of misunderstanding we will take each type separately.

Hornby Loco No. 2

The Locomotive in the No. 2 set is fitted with reversing gear and brake, both of which are controlled by pushing in or pulling out the two levers fitted

inside the cab. The lever on the right-hand side of the cab operates the reversing gear, and the one on the left-hand side operates the brake. If the engine is held upside-down in the hand while each lever in turn is pushed in and pulled out a few times, the operation of the mechanism will be readily followed.

These levers must always be pushed fully in or pulled fully out.

This is specially important in regard to the reversing lever, for if this is left half-in or half-out the gear wheels cannot fall into mesh, and therefore they are liable to be "stripped" by any attempt to force the locomotive to work.

A very valuable feature of this No. 2 Loco is that it may be reversed or braked from the track, without touching the cab levers. This gives a very realistic effect, and is accomplished by means of a special curved rail included in every Hornby No. 2 Train Set. This curved rail is fitted with trip-pieces operated by two levers, and by pushing these levers inwards and at the same time turning them, the trip-pieces are made to project above the track, and they will remain in that position until turned down again. When these trip-pieces are erected it will be noticed that one is to the right of the centre of the track and the other to the left. Looking along the track from the direction in which the engine is approaching, the trip-piece nearest the right-hand side of the track operates the reversing gear and the trip-piece nearest the left-hand side operates the brake.

Reversing from the Track

Suppose now we wish to reverse the engine from the track. The requisite trip-piece is erected, the clockwork wound up, and the train sent off on its journey. When the loco reaches the trip-piece the latter strikes against a small lever projecting downward from the clockwork mechanism (A, Fig. 2) and forces it along, thus reversing the motor. What actually happens is that the loco travels a little way past the trip-piece, pulls up and then starts to run backward. Immediately the engine has passed over the trip-piece the latter must be quickly lowered again, for if this is not done

(Continued on page 311)

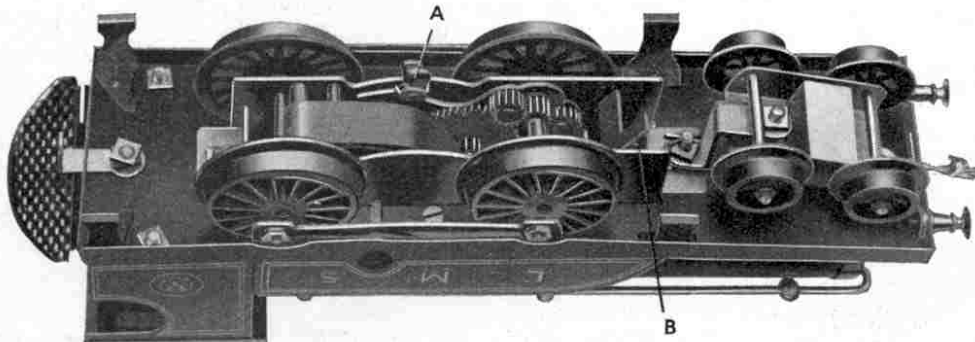

Fig. 2. Underside of Hornby No. 2 Loco

A. Reversing Mechanism.

B. Brake-operating Mechanism.

in the track, and this must be found and made right. An ingenious arrangement has been adopted in order to make the examination of the track a simple and at the same time an accurate process. The back of the handle of the key for winding the loco mechanism is specially designed to the exact inside width between the track rails (Fig. 1). The key thus forms a perfect track gauge, and by sliding it along the track a defective place is discovered at once.

Winding Up the Motor

A question that is very often asked by purchasers of Hornby Trains is "How many turns of the key may I safely give

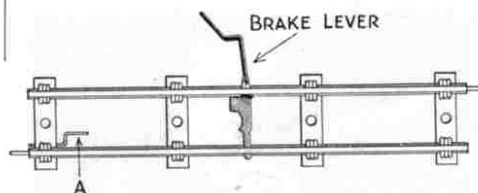

Fig. 3. Straight Rail fitted with brake lever

in winding up the clockwork motor of the loco?" Anxiety on this point is generally the result of sad experience with cheap Continental engines, the clockwork mechanism of which is liable to collapse from the very smallest overstrain. The clockwork motors of the Hornby locos are very stoutly built, however, and the danger of damaging them by over-winding is remote. It is a perfectly safe plan to turn the key as far as it will go *without forcing*, and you will soon be able to tell when to stop turning by the "feel" of the spring as you wind it.

It is very important to remember that the winding key should never be turned backward, for carelessness in this respect

OUR MAIL BAG



In this column the Editor replies to letters from his readers, from whom he is always pleased to hear. He receives hundreds of letters each day, but only those that deal with matters of general interest can be dealt with here. Correspondents will help the Editor if they will write neatly in ink and on one side of the paper only.

G. Alexander (Liverpool).—We agree that many readers would be interested in a cricket column, but until we are able to increase the size of the "M.M." we cannot possibly add a feature of this kind. The name "Meccano" is simply a word coined from the word "Mechanics," and was evolved from the original name, which was "Mechanics Made Easy"—a rather cumbersome title.

G. Gill (Kincardine-on-Forth).—Your cheery letter arrived on a dull, wet morning when everybody was feeling rather grumpy and it did us a world of good. Your riddle is good:—Q. "Why is it foolish to try to light a fire with the 'M.M.'?" A. "Because it is not dry!" It is never going to be dry, G. G., and there is every reason for your belief that the "M.M." will continue to improve with every issue.

S. Miller (Ahooghill, Co. Antrim).—Your suggested cards would certainly be useful in cases where a Guild member is asked the meaning of his badge, and we shall give the idea serious consideration. As regards your query—"How can a bird fall sitting on a tree?" we haven't the slightest idea unless it is "bough-legged" (Sorry—that is a bad one!). Once we start thinking about this sort of thing, we keep at it night and day, and the kindest thing you can do is to tell the answer at once and put us out of our misery!

L. King (Hyde).—The last sentence in your letter—"I don't think you can beat a Meccano boy unless you use a strap"—exactly hits the reason why Meccano boys are so successful. Whether they are engaged in building a model for a competition, or writing prize essays or worrying over puzzles of some kind, we find Meccano boys have a wonderful spirit of dogged perseverance. This, together with the keen and alert brains that are the result of Meccano training, ensures success in almost all circumstances.

L. Bropley (Stoneycroft).—"Why is a mouse when it spins?" Oh! Leonard, we've only just returned from a holiday and it was raining all the time, and we expected something more soothing than this from the first letter that we opened! We liked the rest of your letter though, very much indeed.

W. T. Castle (Clitheroe).—We read your letter with much interest and we shall be happy to see your article on Model Railways, and if suitable, to publish it. We should much like to examine your "Willowdene Model Railway." The new Hornby Train accessories will help you. Like yourself, most boys derive the keenest pleasure from building up a sound toy railway system.

E. Roberts (Leeds).—"Hysteresis" is a term used in physics to denote a retardation or lagging effect and it has nothing to do with your sister's tendencies! If you were an Editor, Eric, you wouldn't be playing with models and trains all the time, and if you only knew what we have to put up with you might never dream of trying to be one. For instance, your friend Simpson "wants to know lots of things about motor-cars and is going to write" to us, and lots of other boys want to know lots of things about lots of other things and they are all going to write to us. It's fine being an Editor, Eric, but it's not easy!

J. Candler (Tulse Hill).—"If there is to be no £250 Competition next year I think I shall die." We hope not, John, but we promise you that if there is no big contest next year, there will be other events that you may find even more interesting and more calculated to save your life and make it happy!

G. Mickleburgh (Bermondsey).—The price of "Railways Shown to the Children" is 3/6, and it is published by Messrs. T. C. & E. C. Jack, of Edinburgh. We have noted your suggestions for special articles and will consider them.

A. Cullen (Dublin).—We are glad to hear from you after so long an interval, and we are interested to know of your radio activities. We do quite a lot of listening-in ourselves when we have time. There is no easy method of learning the Morse code—continuous practice is the only way.

R. Hopford (Kurbessen, Germany).—Sorry, but we scarcely think we shall be able to feature conjuring tricks in the "M.M.," and most of our correspondents tell us that they prefer the present type of articles to serial stories, which they can get in almost any other publication. A Nature column is much called for, however, and we shall commence one soon. Your suggestion for new Meccano plates has been passed on to the right quarter and will be considered.

Electricity—(cont. from page 281)

pipe-lines that run down to the power-house.

Turbines of 30,000 h.p.

The generating plant for this station is being built by Messrs. The English Electric Company, to whom we are indebted for these details of the scheme. Five units are to be constructed, each of which will consist of a twin impulse turbine of 30,000 h.p. driving an alternator generating current at 12,000 volts. These machines will be the largest ever built in this country.

Water Power in Scottish Highlands

Comparatively little has been done to harness water power in England, for here the conditions generally are not favourable for developments of this kind. Considerable progress has been made, however, in Scotland. It is estimated that the waters of the Scottish Highlands are capable of producing over 400,000 h.p., but so far only a small portion of this power has been developed. The British Aluminium Company have a hydro-electric plant at Kinlochleven generating 33,000 h.p. and the company have obtained Parliamentary powers to develop a further scheme which will bring the total up to over 100,000 h.p. Other developments are contemplated, and in a few years something like 150,000 h.p. is expected to be generated throughout the Highlands.

A considerable amount of the available water power in various countries on the Continent has already been developed, and many important schemes are contemplated in the near future. Progress has been most rapid in Switzerland and Scandinavia, where streams and falls exist in abundance.

In this article we have only dealt with water power derived from rivers and waterfalls. Considerable attention is now being devoted to the problem of utilising the enormous power of the tides. The harnessing of the tides demands special methods which are of great interest, and in a future article we intend to describe the progress already made and the possibilities of the future.

Further Adventures in Meccanoland—

(Continued from page 283)

This reminds me that there are lots of good models waiting to be invented. I remember a little while ago seeing in Leeds a large clock in front of which stood the figures of two men. At the stroke of each hour one of the figures struck a bell the correct number of times and the second figure made the same number of strokes on an anvil. I felt at the time that I should be able to reproduce in Meccano these figures and their movements, and I intend to have a try at it, unless some quick-thinking Meccano boy gets in ahead of me.

There were so many thousands of entries in the various sections of the Competition that, in order to get through them in a reasonable time, I could only devote a very few moments to each one, however excellent and novel it might be. At the same time there were a few I did linger over a little, not because they possessed any particular mechanical originality or merit, but because they showed what seemed to me more than usual imagination. In one or two instances the competitors had suggested ideas that might very easily be developed into excellent schemes of play. Mr. Hornby tells me that Meccano boys in steadily-increasing numbers are now building up very comprehensive Hornby Train systems, and many Meccano models are well adapted for use on such railways. Cranes, Bridges, Trucks, Warehouses with elevators, Coaling Stations, Weigh-bridges and Signal Gentries, each a real working model, may all be used and will add a great deal to the completeness of a railway system.

A short time ago I remember seeing in the home of one of my young Meccano friends a most wonderful model of the Forth Bridge, on which had been laid a double track of rails for the builder's trains. Of course, such a model as this requires a very big room, but every boy who possesses a Hornby loco, coaches, wagons and a set of rails can use the smaller Meccano Cranes, Warehouses, etc., with splendid effect. Just take a glance at a model of a Railway Station sent in by Donald Crankshaw, of Nelson, and I am sure you will realise the force of what I am saying. Here we have a complete station with signals, bridge and signal box, all made with Meccano parts and looking most realistic and effective. This is certainly an idea which might be carried much further and I commend it to all my readers who own Meccano and Hornby Trains.

Quite a number of competitors had sent in models of Bicycles, but I did not see anything that seemed to me altogether satisfactory. I am illustrating a typical example entered by F. E. Salom, of Barcelona. This model is nicely proportioned, although I feel sure that many of the details could be greatly improved.

I lingered a long time over the models that had won Championship Cups for their inventors, and I should like nothing better than to build each one by myself with the aid of the photographs and drawings that accompanied them. I wish I had space to go on and tell my readers about each one of them, but I am afraid I have already exceeded the space at my disposal. Anyhow, Mr. Hornby informs me that all the Championship models will be built up, photographed, described and published in the *Meccano Magazine* in due course, as soon as opportunity allows this considerable task to be undertaken.

A Meccano Champion



Albert Shaw, of Nottingham, winner of the Meccano Championship Cup in Section B of the £250 Model Building Competition. His model of a Twisting Machine is very ingenious, and the award was well merited.