

Earth rotates round the Sun in the same time that it takes to rotate upon its own axis 365 times, while the Moon makes 13 revolutions round the Earth in the same period. The Moon always presents the same face to the Earth, and the axis of the latter body is so inclined that there is an angle between the plane of the equator and that of the earth's orbit of $23\frac{1}{2}$ degrees. The Meccano model reproduces these movements and positions with considerable accuracy.

The Sun is indicated at 1, the Earth at 2, and the Moon at 3 (Fig. A). Suitable spheres or balls to represent these bodies may be obtained quite easily, and no trouble should be found in securing them to their respective shafts. The appearance of the model will be enhanced if the globes are painted to represent the markings on the surfaces of the Earth and Moon, etc.

The Motor is mounted at the end of the revolving portion, or arm, of the model and its weight, together with that of the Meccano 8 ampere-hour Accumulator slung in a suitable frame beneath the Motor, serves to counterbalance the weight of the Earth and Moon, etc., on the other end of the arm.

The drive is led first to the Earth spindle 2a by way of two 3:1 reduction gears mounted on the Motor, and Bevel Wheel 4. The latter engages with a similar wheel secured to the shaft 5, which consists of two 8" Rods secured together by a Coupling. The other end of this shaft 5 carries a $\frac{1}{2}$ " Pinion gearing with a $1\frac{1}{2}$ " Contrate Wheel 6 secured to a vertical Rod that is connected to the Earth spindle 2a by means of a Universal Coupling 7. This allows the Rod 2a to be placed at an angle corresponding to the "tilt" of the Earth's axis.

How the Moon is Operated

The motion of the spindle 2a is conveyed to a short Rod 8 by means of a length of Sprocket Chain and two $1\frac{1}{2}$ " Sprocket Wheels, and a $\frac{3}{4}$ " Pinion secured to this Rod 8 drives a 50-teeth Gear Wheel secured to another 2" Rod carrying the $\frac{3}{4}$ " Pinion 9. The latter, in turn, engages with another 50-teeth Gear Wheel secured to the shaft of the $\frac{3}{4}$ " Pinion 10, which engages with the teeth of a $3\frac{1}{2}$ " Gear Wheel 11. The Gear Wheel 11 is secured by Strips to the arm so that it cannot rotate, the Earth spindle being free to move within its boss, of course.

The gear train 8, 9, 10 is carried in an arm that pivots about the Rod 2a and since the Pinion 10, when in motion, must travel round the teeth of the immovable wheel 11, this arm together with the Moon 3 secured to its outer end, is caused to turn slowly round the Earth 2. The gear ratio is such that one complete revolution of the arm carrying the Moon takes place once in 28 revolutions of the Earth sphere 2. And since one revolution of the latter must indicate the passage of a single 24-hour day each complete circuit described by the sphere 2 corresponds to the 28-day lunar month.

The phenomenon of night, or the transit from daylight to

darkness that takes place over the greater portion of the earth's surface once in every 24 hours, may easily be illustrated by adding a small electric light in place of, or in addition to, the Sun globe 1.

In order to secure smooth working, the weight of the Moon and its gear train is counterbalanced by a series of $2\frac{1}{2}$ " Strips 12 mounted on the opposite end of the revolving arm.

Earth's Passage Round the Sun

Fig. B is a detail view of the model and shows the opposite side of the main revolving arm. From this illustration it will be seen that the lower portion of the Earth spindle carries a Worm 13 engaging with a $\frac{1}{2}$ " Pinion 14 that is secured to a short Rod journalled in the end of the arm. This Pinion 14 gears with a similar Pinion mounted on the end of a shaft 15, consisting of two $6\frac{1}{2}$ " Rods secured end to end by a Coupling, on the other end of which is a second Worm 16 engaging with the teeth of a $\frac{1}{2}$ " Pinion secured to a vertical Rod 17.

This Rod 17 is gripped by the set-screw of the 3" Pulley 18,

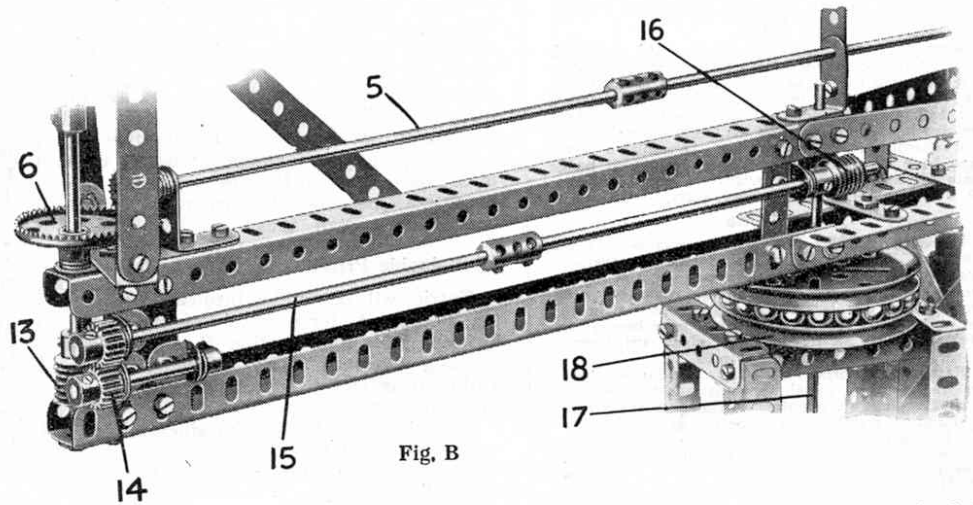

Fig. B

which is bolted to the base and forms the fixed race of the ball bearings on which the movable portion of the model rests. The construction of the ball bearing unit is identical to that described under Meccano Standard Mechanism No. 104/5, the upper 3" Pulley of the unit being secured to the rotating superstructure. The Worm 16 is driven very slowly from the motion of the Earth spindle and because the $\frac{1}{2}$ " Pinion with which it gears is quite rigid, it has the effect of turning the whole superstructure about the Rod 17. Thus the Earth 2 and Moon 3 are carried round the Sun 1.

The two separate worm gears incorporated in the drive transmission reduce the speed of rotation to such an extent that the Rod 2a must rotate 361 times before the superstructure completes one revolution. This closely approximates to the actual number required, for the Earth revolves 365 times about its own axis while journeying once round the Sun. The sum of these 365 turns, or days, makes what we term a year.

A Snapshot Competition

The many photographic enthusiasts among our readers will welcome the announcement that Gevaert Ltd., whose advertisement appears on page 568 of this issue, are organising a competition for snapshotters and are awarding valuable cash prizes each month for happy snapshots. Here is an excellent chance to make your camera pay for its season's upkeep.

The rules are very simple. Any size photograph is eligible and no entry forms are necessary. The only stipulation is that each photograph must be accompanied by a GAYVERT film carton. As many prints as desired may be entered at any time each month up to 30th September but a carton must accompany each. Full details of this competition appear in Gevaert Ltd.'s advertisement this month.

Wang's "Flexible Brain"!

The following letter was recently received by a financial house in Peking:—

"DEAR SIR,—I am Wang. It is for my personal benefit that I write for a position in your honourable Bank.

"I have a flexible brain that will adapt itself to your business and in consequence bring good efforts to your good selves. My education was impressed upon me in Peking University in which place I graduated Number One.

"I can drive a typewriter with a good noise and my English is great.

"My references are of good and should you hope to see me they will be read by you with great pleasure.

"My last job has left itself from me for the good reason that the large man has dead. It was on account of no fault of mine. So, honourable sir, what about it? If I can be of big use to you, I will arrive on some date that you should guess.— Faithfully yours, 'WANG.'"

Important Babies at the Zoo

Among the outstanding possessions of the London Zoo is the recently-born East African buffalo. This interesting animal attracts a good deal of attention, as it is nearly 15 years since an East African buffalo was last born in the Zoo gardens.

Equally important is the baby hippopotamus and fortunately he is a much less delicate animal. In fact he is distinctly substantial for a baby and is now practically big enough to take care of himself. While younger he was the cause of a family separation. There was scarcely room enough in the small indoor tank in which these animals enjoy a bath for the two older hippopotami and there was a great risk that between them Jimmy would accidentally be crushed if he also ventured into the water. So they were separated, but soon it will be Jimmy's turn to live by himself.

A New Meccano Orrery

Illustrating the Motion of the Earth and Moon

AN astronomical instrument in which interest has recently been revived is the orrery, which illustrates the motion of the planets and their moons about the Sun. An instrument of this kind seems to have been first made slightly more than 200 years ago by a man named Graham and the first well-known example of it was constructed in 1715 by John Rowley for Charles Boyle, the Earl of Orrery, from whose title its name is derived. An excellent example of the apparatus, made about 1770 by Benjamin Martin, is to be seen in the Science and Art Museum, South Kensington.

Charles Boyle was a member of the famous family founded

by Richard Boyle, commonly known as the Great Earl of Cork. Richard Boyle was a great statesman whose active career in Ireland lasted from the time of the Armada in 1588 to the outbreak of civil war in the reign of Charles I. One of his sons was Robert Boyle, the famous chemist who was one of the founders of the Royal Society of London, while another was Lord Broghill, who so greatly distinguished himself as a soldier and statesman under Cromwell and Charles II. that he was made Earl of Orrery.

The Charles Boyle for whom the orrery was built combined some of the qualities of both these ancestors. He played a creditable part in public affairs in the early days of the eighteenth century and used to amuse himself during his leisure hours with mechanical toys.

The Functions of an Orrery

The orrery soon proved to be much more than a mechanical toy however. It is impossible to represent the solar system mechanically with absolute accuracy, of course, the great difficulty being the correct reproduction of the sizes and distances apart of the planets. If the Earth, for instance, in such an instrument is represented by a sphere of the diameter and weight of a halfpenny, the Sun would have to be a huge globe weighing considerably more than a

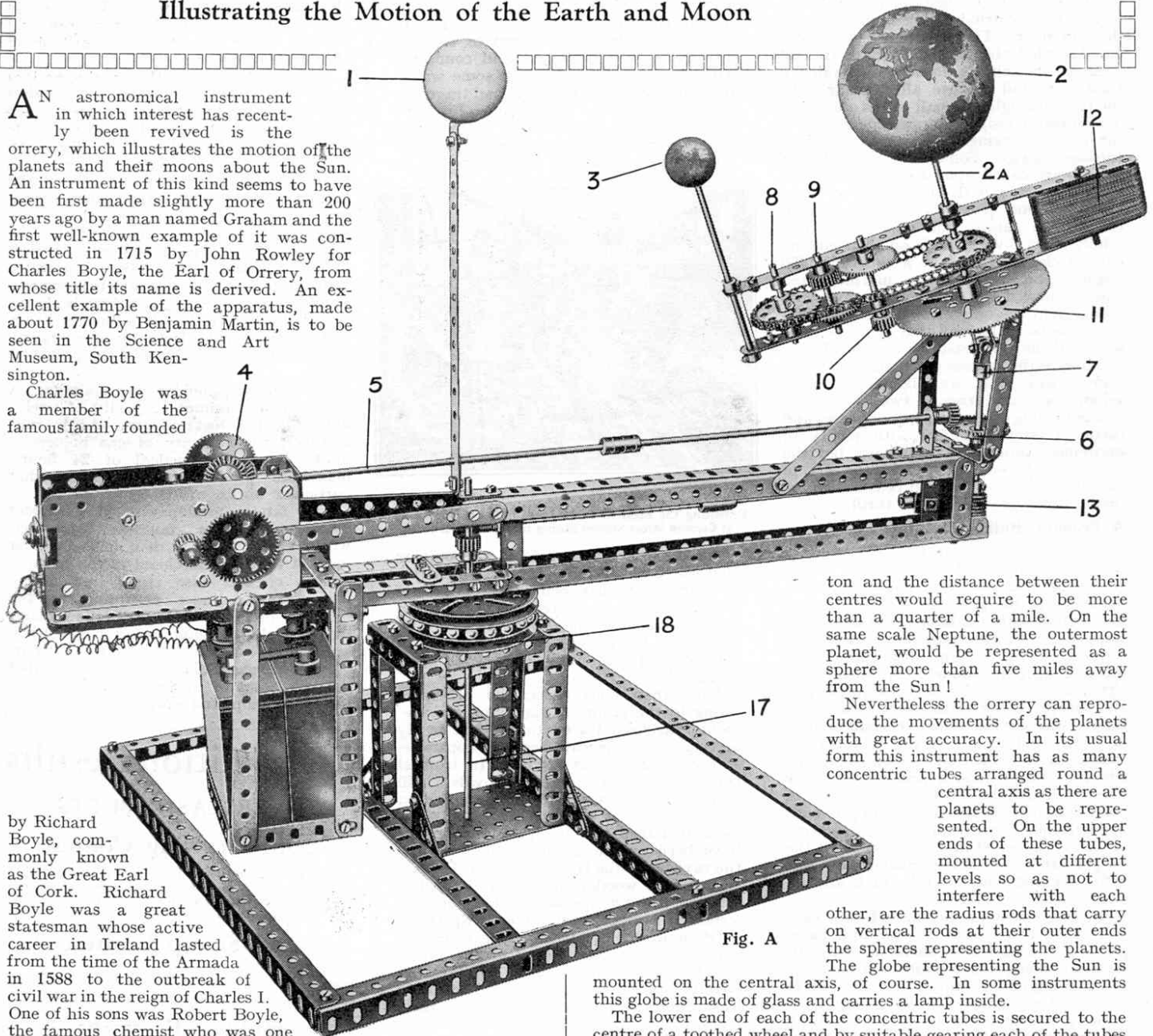

Fig. A

ton and the distance between their centres would require to be more than a quarter of a mile. On the same scale Neptune, the outermost planet, would be represented as a sphere more than five miles away from the Sun!

Nevertheless the orrery can reproduce the movements of the planets with great accuracy. In its usual form this instrument has as many concentric tubes arranged round a central axis as there are planets to be represented. On the upper ends of these tubes, mounted at different levels so as not to interfere with each

other, are the radius rods that carry on vertical rods at their outer ends the spheres representing the planets. The globe representing the Sun is mounted on the central axis, of course. In some instruments this globe is made of glass and carries a lamp inside.

The lower end of each of the concentric tubes is secured to the centre of a toothed wheel and by suitable gearing each of the tubes is made to rotate round the Sun at the appropriate rate for the particular planet associated with it. Thus the tube carrying the sphere representing Jupiter is so geared that it rotates once while that carrying the sphere representative of the Earth travels round almost twelve times, thus indicating the difference between the periods in which these two planets complete their orbits.

More complications ensue when the rotations of the planets themselves and the movements of their moons are also to be represented. Even this can be done, however, and an orrery combining all these movements can be constructed without difficulty from standard Meccano parts.

The Movements of the Model

The model depicted on this page demonstrates the annual journey of the Earth and its satellite, the Moon, round the Sun, and is yet another remarkable illustration of the practical value of Meccano.

The movements to be represented are three in number. The

MODEL OF THE MONTH

A Meccano Orrery

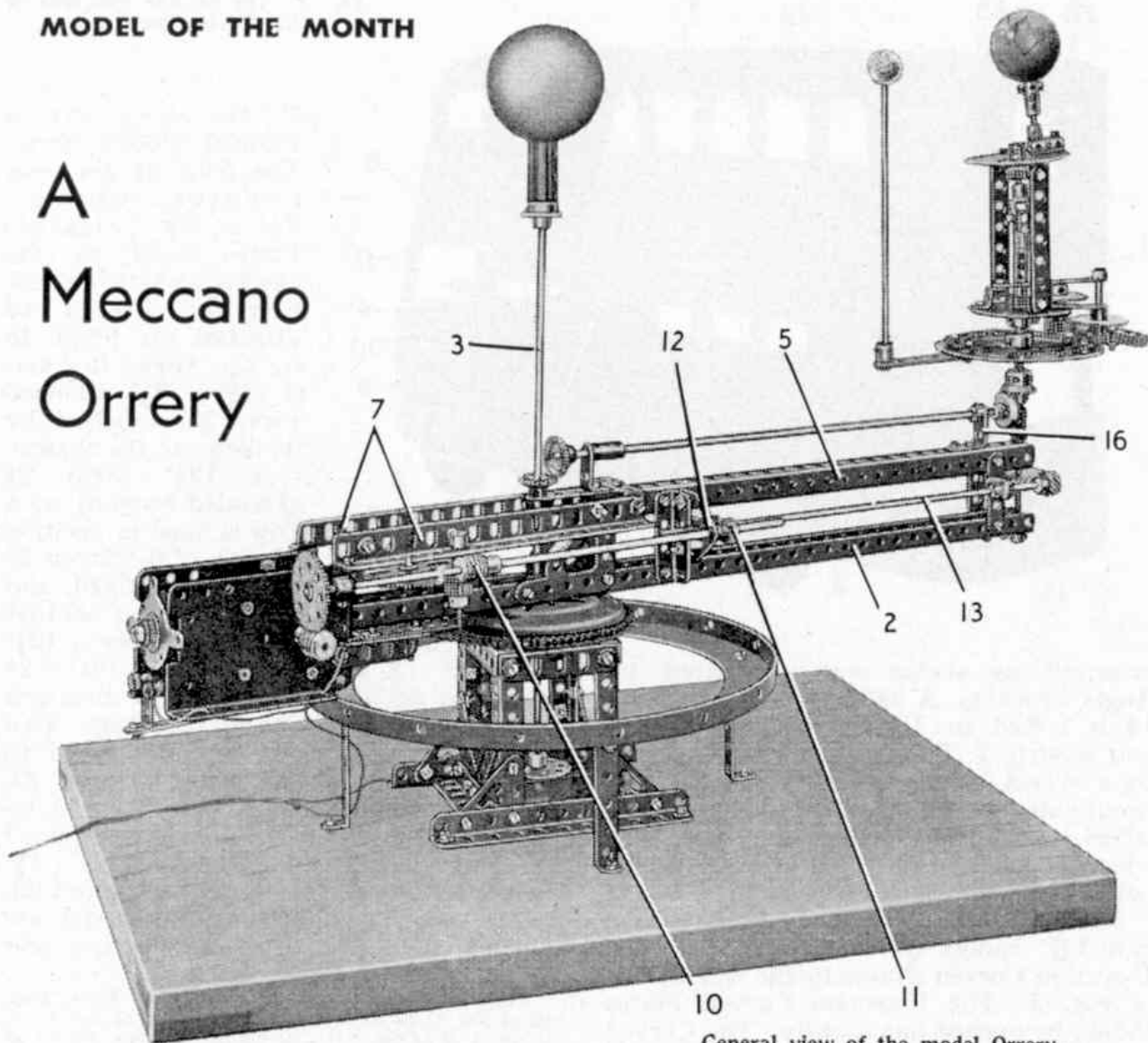

General view of the model Orrery.

AN Orrery is an astronomical instrument of great interest that illustrates the motion of the planets about the Sun, and the operation of the moons of the planets. The earliest instrument of this kind seems to have been made in 1715 for the Earl of Orrery, from whose title its name is derived.

In its usual form an orrery has a number of concentric tubes arranged round a central axis, on which the sphere representing the Sun is mounted. On the upper ends of these tubes, mounted at different levels so as not to interfere with each other, are radial rods of various lengths, on the outer ends of which spheres of various sizes are mounted to represent the planets, and similar arrangements apply to their satellites. The lower end of each of the concentric tubes is driven by means of gearing so as to give the correct movements of the heavenly bodies concerned.

In a Meccano model it is impossible to keep exactly to scale because of the immense range of distances involved. This is easily seen when we realise that if in a model the distance of the Earth from the Sun is represented by a rod 1 ft. in length, that of Pluto, the outermost planet, would be represented by one nearly 40 ft. long, and then the distance from the Sun of the sphere representing Mercury, the innermost planet, would be only $4\frac{1}{2}$ inches. For this reason the present model is restricted to the movements of the Sun, Earth and Moon. To include more would require very complicated gearing.

Thus the Orrery we have chosen as the subject for the June "Model of the Month" demonstrates the annual journeys of the Earth round the Sun and of its satellite the Moon round the Earth, and also illustrates their rotations. It is based

A close-up view of the spheres representing the Earth and the Moon. In it the gearing and general arrangement of the drive can be seen.

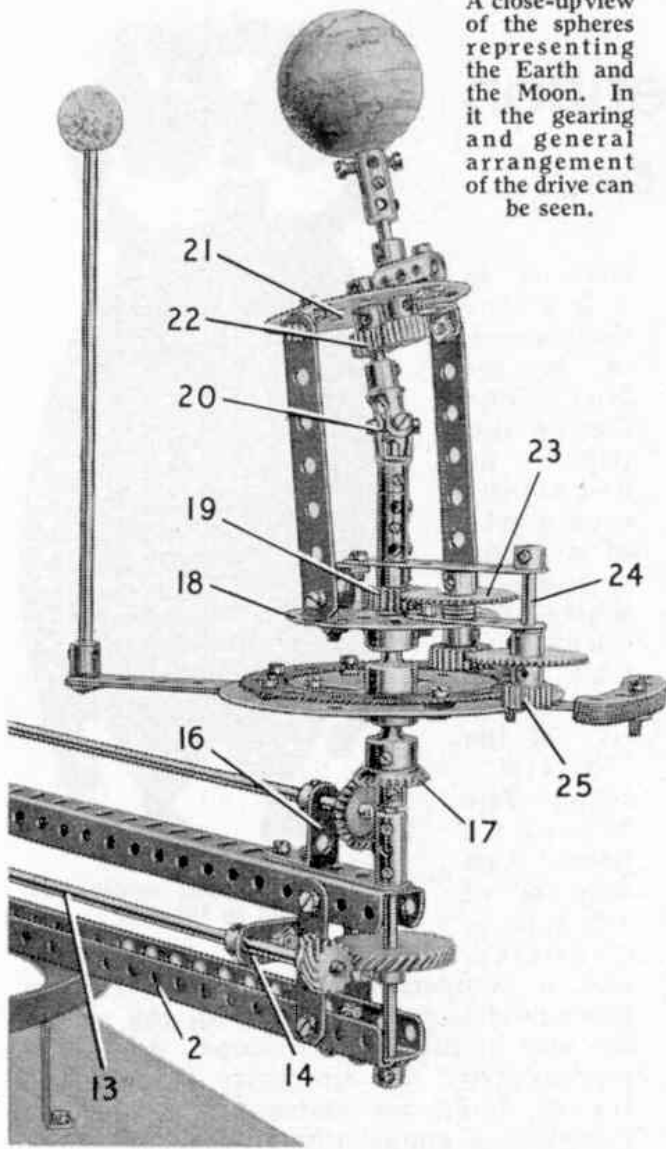

on a model entered by Mr. de Beer, Leader of the Cape Peninsula Meccano Club, in a recent model-building Competition. The gearing ensures that the Earth rotates round the Sun in the same time that it takes to rotate upon its own axis 365 times, while the Moon makes 13 revolutions round the Earth in the same period. The Moon always presents the same face to the Earth, and the axis of the latter body is so inclined that there is an angle of $23\frac{1}{2}$ degrees between the plane of its equator and that in which it rotates round the Sun.

Suitable spheres or balls to represent the Sun, Earth and Moon may be obtained quite easily, and no trouble should be met in securing them to their respective shafts. The appearance of the model will be enhanced if the globes representing the Earth and Moon are painted to show or suggest the markings on the surfaces. That representing the Sun also could be painted bright yellow.

The model is driven by a Meccano Motor mounted on the end of the main revolving arm, current being collected by a shoe in contact with a pick-up ring.

Full instructions and a list of the parts required to build the Meccano Orrery can be obtained by writing to the Editor, enclosing a 2d. stamp for postage. Readers in Canada, Australia, New Zealand, South Africa, United States of America and Ceylon can obtain instructions for the current "Model of the Month" by writing to the main Meccano Agents for those countries, enclosing suitable stamps for return postage.

This view of the base and Motor of the model shows the current pick-up ring and collector shoe.

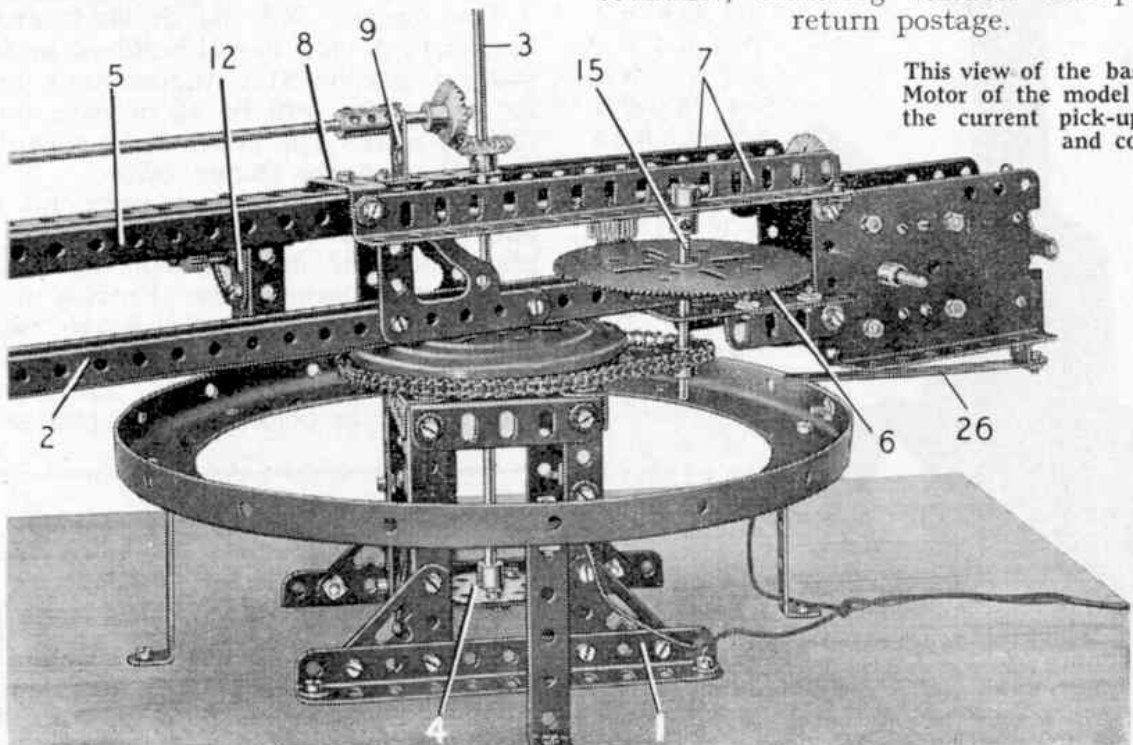

MECCANO ORRERY

Illustrated in the June 1957 issue of the "Meccano Magazine."

Construction of the Base

Two vertical $3\frac{1}{2}$ " Angle Girders are bolted to a $5\frac{1}{2}$ " Angle Girder 1 to form each side of the base. The $3\frac{1}{2}$ " Angle Girders are braced by $1\frac{1}{2}$ " Corner Brackets, and they are connected at their upper ends by a $2\frac{1}{2}$ " Angle Girder. The sides of the base are connected by four $3\frac{1}{2}$ " Angle Girders and the structure is braced by $2\frac{1}{2}$ " Strips. A Toothed Disc from a Ball Thrust Race is fixed to the top of the base. The complete assembly is bolted to a suitable baseboard.

Assembly of the Rotating Arm

Two $18\frac{1}{2}$ " Angle Girders are bolted together to form a channel girder 2, and this is fixed to the Flanged Disc of a Ball Thrust Race. The Flanged Disc and the Toothed Disc fixed to the base are then arranged with the Ball Cage between them, and an $11\frac{1}{2}$ " Rod 3 is passed through the assembly. The lower end of this Rod is fixed in a Bush Wheel 4 bolted to two $2\frac{1}{2}$ " x $\frac{1}{2}$ " Double Angle Strips attached to the base. A Collar is fixed on the Rod 3 to hold together the sections of the Ball Thrust Race.

Two $12\frac{1}{2}$ " Angle Girders are connected to form a channel girder 5, and this is supported by two 2" Strips and two Corner Gussots bolted to the girder 2. A $2\frac{1}{2}$ " x $2\frac{1}{2}$ " Flat Plate 6 is fixed to one end of girder 2, and two 2" Angle Girders are bolted to the edges of the Flat Plate. An ESOR(S) Electric Motor is fixed to the projecting ends of the 2" Angle Girders. A $7\frac{1}{2}$ " Angle Girder 7 is connected to each side-plate of the Motor by an Angle Bracket, and is bolted to a $1\frac{1}{2}$ " x $\frac{1}{2}$ " Double Angle Strip 8 fixed to the girder 5. The bolt securing the Double Angle Strip supports also a 1" x 1" Angle Bracket 9, and a $2\frac{1}{2}$ " Strip passed over the Rod 3.

The Rod 3 is used to support the ball representing the sun.

Arrangement of the Main Drive

A Worm on the Motor armature shaft engages a 57-tooth Gear on an $11\frac{1}{2}$ " Rod that carries also a Worm 10 and a $\frac{1}{2}$ " Pinion 11. The $11\frac{1}{2}$ " Rod is supported in a 1" x 1" Angle Bracket bolted to the Motor side-plate and connected to the Girder 7 on the same side by a Fishplate, and in a Flat Transition 12 bolted to a 2" Angle Girder. An $11\frac{1}{2}$ " Rod 13 supported in the Flat Transition and in a Fishplate bolted to a 1" x $\frac{1}{2}$ " Angle Bracket 14, carries a $\frac{1}{2}$ " Pinion that meshes with the Pinion 11.

The Worm 10 drives a $\frac{3}{4}$ " Pinion on a Rod mounted in the Flat Plate 6 and one of the Girders 7. A $\frac{1}{2}$ " Pinion on the same Rod meshes with a $3\frac{1}{2}$ " Gear on a Rod 15, which carries a $\frac{3}{4}$ " Sprocket. The Sprocket is connected by Chain to the Toothed Disc of the Ball Thrust Race.

The Drive to the Earth

A $\frac{1}{2}$ " Helical Gear on the end of Rod 13 drives a $1\frac{1}{2}$ " Helical Gear

on a $6\frac{1}{2}$ " Rod, which is mounted in a $1\frac{1}{2}$ " and a $2\frac{1}{2}$ " Strip bolted to the girders 2 and 5. The bolts fixing the $2\frac{1}{2}$ " Strip secure also a 1" x 1" Angle Bracket 16.

The $6\frac{1}{2}$ " Rod is fitted with a Coupling and a Collar, then an assembly formed by a $\frac{7}{8}$ " Bevel Gear 17 fixed in a Socket Coupling, another Socket Coupling connected to the first by a Short Coupling, and a Face Plate 18 held in the upper Socket Coupling. Before the upper Socket Coupling is fixed on the Short Coupling, a 4" Circular Plate is passed over the Short Coupling so that the Circular Plate is able to rotate freely. The complete assembly of the Socket Couplings, the Bevel Gear and the Face Plate must be free to rotate on the $6\frac{1}{2}$ " Rod. A $\frac{5}{4}$ " Pinion 19 and a Coupling can now be fixed on the $6\frac{1}{2}$ " Rod, and a Universal Coupling 20 is connected to the Coupling by a 1" Rod.

A Face Plate 21 is connected by Angle Brackets to $3\frac{1}{2}$ " Strips, which are attached to Angle Brackets bolted to the Face Plate 18. A $1\frac{1}{2}$ " Rod is passed through the boss of the Face Plate 21, is fitted with a $\frac{1}{3}$ " Pinion 22, and is fixed in the Universal Coupling 20. Pinion 22 engages a $\frac{1}{2}$ " Pinion on a $1\frac{1}{2}$ " Rod mounted in a Coupling attached to Face Plate 21 by a $\frac{1}{2}$ " Bolt. The upper end of the $1\frac{1}{2}$ " Rod carries a Coupling used to support the globe representing the earth.

An $11\frac{1}{8}$ " Rod is extended by a $1\frac{1}{2}$ " Rod connected by a Coupling, and these Rods are mounted in the Angle Brackets 9 and 16. A $\frac{7}{8}$ " Bevel Gear is fixed on the $1\frac{1}{2}$ " Rod and meshes with a similar Bevel Gear fixed on the Rod 3. A $\frac{7}{8}$ " Bevel Gear fixed on the end of the $11\frac{1}{8}$ " Rod engages the Bevel Gear 17.

The Drive to the Moon

A Gear Ring is attached to the 4" Circular Plate but is spaced from it by a nut on each bolt. The arm supporting the Rod carrying the ball representing the moon is formed by three $3\frac{1}{2}$ " Strips. These are bolted to the Circular Plate and they carry a Rod Socket. The arm is counter-balanced by eight $2\frac{1}{2}$ " Curved Strips attached to a 2" Strip, which is bolted to the Circular Plate directly opposite to the arm.

A 2" Strip is bolted to the Face Plate 18, and a 3" Strip is placed on the $6\frac{1}{2}$ " Rod between Pinion 19 and the Coupling above it. The 3" Strip is connected to the Face Plate 18 by a $\frac{1}{2}$ " Reversed Angle Bracket. Pinion 19 drives a 50-tooth Gear 23 on a 1" Rod, which carries also a $\frac{3}{4}$ " Pinion arranged below the Face Plate 18. This Pinion drives a 50-tooth Gear on a Rod 24, mounted in the 2" and the 3" Strips, and a $\frac{1}{2}$ " Pinion 25 on the same Rod engages the Gear Ring.

Details of the Current Supply

A length of wire is attached to one terminal of the E20R(S) Electric Motor, and is connected to one of the Girders 7 by a bolt, so that the terminal is "earthed" to the frame of the model.

Four $2\frac{1}{2}$ " x $\frac{1}{2}$ " Double Angle Strips are bolted to a Flanged Ring, and these are attached to the baseboard as shown. The Flanged Ring must be arranged so that the Rod 3 is located at the exact centre. A 1" x $\frac{1}{2}$ " Angle Bracket is fixed on the second terminal of the Motor, and a $4\frac{1}{2}$ " Strip 26 bolted to the Angle Bracket presses against the Flanged Ring. The enamel should be removed from the end of the Strip and from the edge of the Flanged Ring to ensure good electrical contact. One wire from the source of current-supply is connected to the Flanged Ring and the other is bolted to the base that supports the rotating arm.

PARTS REQUIRED

| | | |
|-------------|--------------|---------------------------|
| 1 of No. 2A | 2 of No. 18a | 1 of No. 94 |
| 5 " " 3 | 2 " " 18b | 1 " " 96a |
| 1 " " 4 | 1 " " 20b | 2 " " 108 |
| 6 " " 5 | 1 " " 24 | 2 " " 109 |
| 4 " " 6 | 3 " " 25 | 1 " " 111a |
| 1 " " 6a | 6 " " 26 | 12 " " 111c |
| 2 " " 7a | 2 " " 27 | 1 " " 125 |
| 2 " " 8 | 1 " " 27a | 1 " " 126a |
| 2 " " 8b | 1 " " 27b | 4 " " 133 |
| 2 " " 9 | 4 " " 30 | 1 " " 140 |
| 8 " " 9b | 2 " " 32 | 1 " " 146a |
| 2 " " 9d | 110 " " 37a | 1 " " 163 |
| 3 " " 9e | 90 " " 37b | 1 " " 167b |
| 2 " " 10 | 34 " " 38 | 1 " " 168 |
| 6 " " 12 | 1 " " 48 | 2 " " 171 |
| 3 " " 12a | 6 " " 48a | 1 " " 179 |
| 2 " " 12b | 10 " " 59 | 1 " " 180 |
| 4 " " 13 | 5 " " 63 | 1 " " 211a |
| 2 " " 14 | 1 " " 63d | 1 " " 211b |
| 1 " " 16b | 1 " " 72 | 1 E20R(S) Electric Motor. |
| 3 " " 17 | 8 " " 90 | |
