

Railway Breakdown Crane

The main side girders 1 (Fig. 3) are channel in section, each being built up from one $18\frac{1}{2}$ "", one $7\frac{1}{2}$ " and two $5\frac{1}{2}$ " Angle Girders. (The $7\frac{1}{2}$ " and $5\frac{1}{2}$ " Girders are used in order that the model may be built with a No. 7 Outfit; it would be preferable, of course, to use two $18\frac{1}{2}$ " Girders for each side member). The girders so formed are connected together at each end and at various other points by $4\frac{1}{2}$ " Angle Girders

2. The buffer beams are formed by $4\frac{1}{2}$ " \times $2\frac{1}{2}$ " Flat Plates, which are attached to the $4\frac{1}{2}$ " Angle Girders at each end of the girders 1. Two $2\frac{1}{2}$ " \times $2\frac{1}{2}$ " Flat Plates 5 and $3\frac{1}{2}$ " \times $2\frac{1}{2}$ " Flanged Plates 6 are bolted to each girder 1, a gap being left between each Plate. The end Plates adjoining the buffer beam are connected to the latter by means of $2\frac{1}{2}$ " Angle Girders, while the buffer beam at the other end of the truck is reinforced by $2\frac{1}{2}$ " Angle Girders and Corner Brackets, the

latter forming a rigid connection between the $2\frac{1}{2}$ " Girders and the side members 1. A $9\frac{1}{2}$ " Flat Girder 7 is bolted along the lower edges of the Plates on each side of the truck, and as there is a gap of one hole between the Plates, the slotted holes of the Flat Girder are unobstructed at this point. The purpose of this will be explained later.

The two $4\frac{1}{2}$ " Angle Girders 3 form a rigid means of attaching to the truck the $3\frac{1}{2}$ " Gear Wheel 4 (Fig. 2) which forms the lower portion of the ball race on which the model slews. It is attached to the truck by means of four $\frac{1}{4}$ " Bolts, Collars being used for spacing purposes.

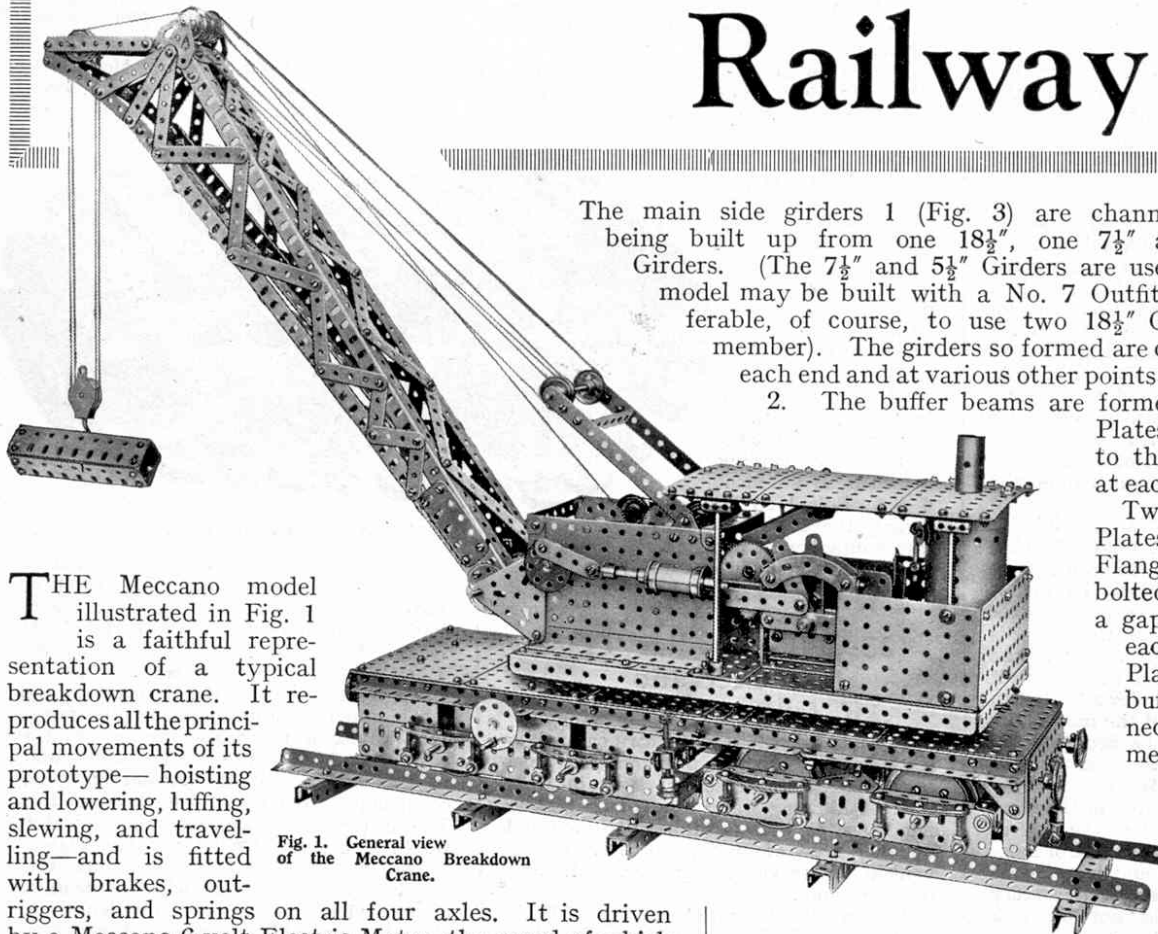

Fig. 1. General view of the Meccano Breakdown Crane.

THE Meccano model illustrated in Fig. 1 is a faithful representation of a typical breakdown crane. It reproduces all the principal movements of its prototype—hoisting and lowering, luffing, slewing, and travelling—and is fitted with brakes, outriggers, and springs on all four axles. It is driven by a Meccano 6-volt Electric Motor, the speed of which may be regulated by a built-up Meccano controller. As the actual crane is steam-operated, a dummy boiler and engine are incorporated in the model. The crane truck is about 20" in overall length and is designed to run on 3" gauge rails, which may of course be built up from Meccano Angle Girders, etc.

The constructional details of the model will be dealt with fully in two special articles, of which this is the first. The second article will appear next month. This article includes full details for building the crane truck, bogie, and wheel mechanism; and in the August issue we shall describe the swivelling superstructure, jib, gear-box mechanism, and a special type of resistance controller for regulating the Motor.

There are many Meccano boys who will want to build this model, not only for the pleasure to be had from its construction, but for the fun of working it when completed. By the touch of a lever the model may be made to roll slowly forward, or slew, luff, and hoist just like a real crane. With the aid of the numerous illustrations accompanying the articles, no difficulty should be experienced in building a successful model.

Construction of the Crane Truck

The construction of the model should be commenced by building the crane truck. As will be seen from Fig. 1 and the various sectional views (Figs. 2, 3 and 5), the truck is very solidly built and is complete down to the smallest detail.

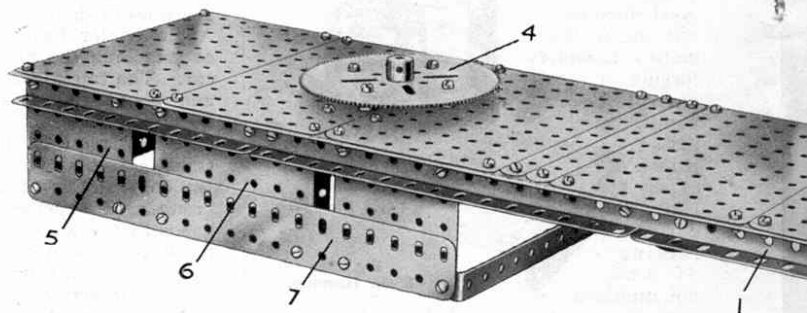

A reinforced bearing 3a (Figs. 3 and 5), composed of a $1\frac{1}{2}$ " Strip bolted to two $1\frac{1}{2}$ " Angle Girders, is then attached to the Girders 3. Care should be taken to ensure that a Rod, when passed through the boss of

Fig. 2. The Truck from the Meccano Breakdown Crane. The Gear Wheel 4 forms the lower portion of the ball race.

ccano Model

akdown Crane

SPECIAL FEATURES

The various movements of the model, hoisting and lowering, slewing, luffing, and travelling, are all driven by a 6-volt Motor through a gear box of unique design. The crane truck is mounted on eight sprung wheels, four of which are carried in a swivelling bogie. Other details include brakes on the travelling wheels and outriggers.

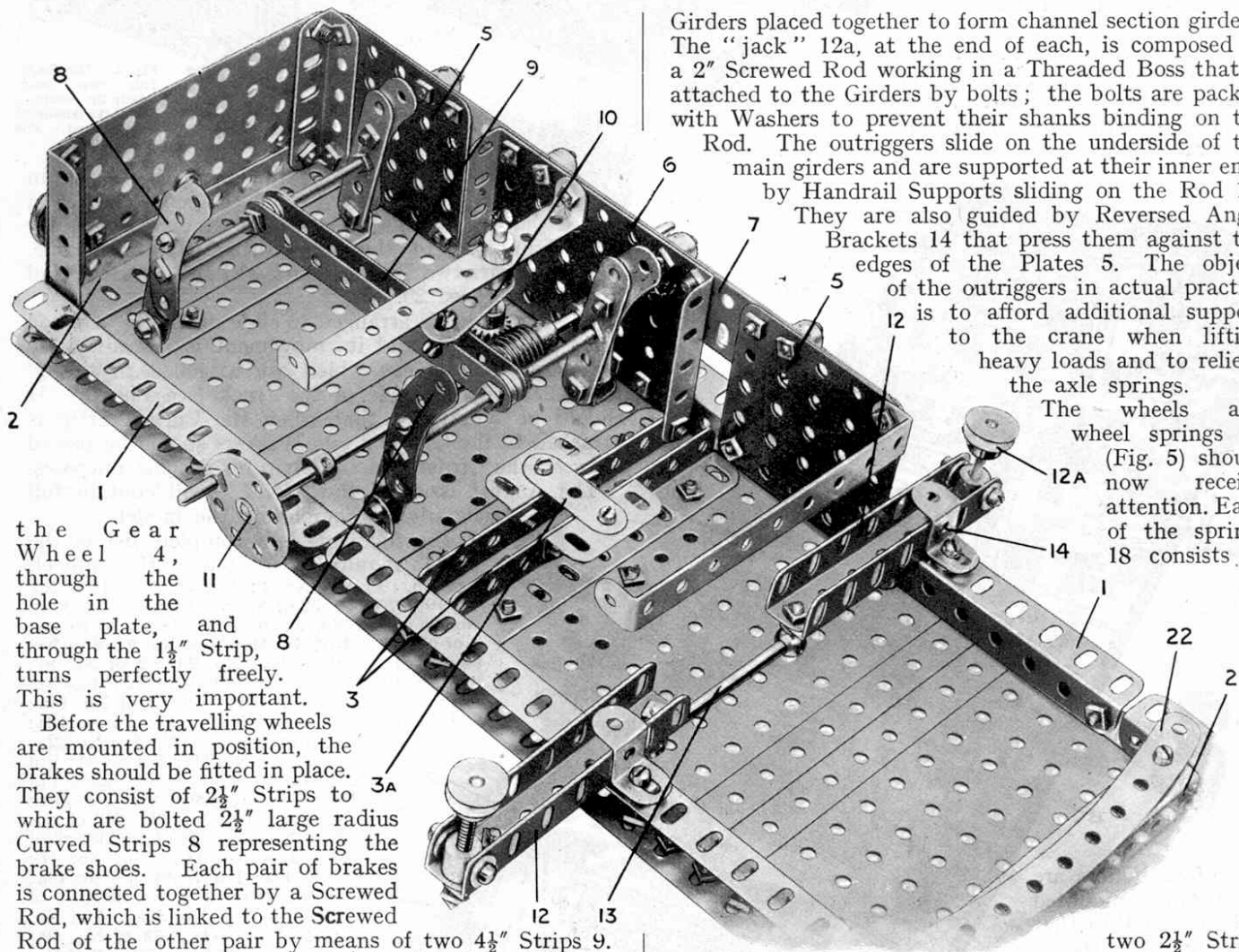

the Gear Wheel 4, through the hole in the base plate, and through the $1\frac{1}{2}$ " Strip, turns perfectly freely. This is very important.

Before the travelling wheels are mounted in position, the brakes should be fitted in place. They consist of $2\frac{1}{2}$ " Strips to which are bolted $2\frac{1}{2}$ " large radius Curved Strips 8 representing the brake shoes. Each pair of brakes is connected together by a Screwed Rod, which is linked to the Screwed Rod of the other pair by means of two $4\frac{1}{2}$ " Strips 9. The Strips are spaced apart the distance of five Washers and retained in position on the Rods by lock-nuts. A Crank 10 is secured on a short Rod journalled in a hole of the base plate and also in a $4\frac{1}{2}$ " Double Angle Strip as shown in Figs. 3 and 5. The Rod carries a $\frac{1}{2}$ " Pinion that is arranged to mesh with a Worm on a $6\frac{1}{2}$ " Rod on which the hand wheels 11 are secured. The Crank is attached pivotally to the links 9 by means of a bolt inserted in the set-screw hole of a Collar, which is held in place between the links by a $\frac{1}{2}$ " Bolt. By turning the handwheels 11, the Crank swings slowly and presses the brake shoes on to the wheels.

Each of the "outriggers" 12 (Fig. 3) consists of two $3\frac{1}{2}$ " Angle

Girders placed together to form channel section girders. The "jack" 12a, at the end of each, is composed of a 2" Screwed Rod working in a Threaded Boss that is attached to the Girders by bolts; the bolts are packed with Washers to prevent their shanks binding on the Rod. The outriggers slide on the underside of the main girders and are supported at their inner ends by Handrail Supports sliding on the Rod 13. They are also guided by Reversed Angle Brackets 14 that press them against the edges of the Plates 5. The object of the outriggers in actual practice is to afford additional support to the crane when lifting heavy loads and to relieve the axle springs.

The wheels and wheel springs 18 (Fig. 5) should now receive attention. Each of the springs 18 consists of

two $2\frac{1}{2}$ " Strips and one $1\frac{1}{2}$ " Strip. A Bolt with a Washer

Fig. 3. Underneath view of Crane Truck, with one side and wheel mechanism removed to show the Brake rigging and Outriggers.

on its shank is passed through the centre hole of all three Strips and inserted in a Collar. The "spring hangers" 19 are $\frac{3}{4}$ " Bolts inserted in Collars that are attached pivotally to the frame by $\frac{1}{2}$ " lock-nutted Bolts. Fig. 4 shows the springs very clearly. The wheels themselves consist of Face Plates bolted to Wheel Flanges; eight in all are required.

The driving axle 15a (Fig. 5) has secured to it a $1\frac{1}{2}$ " Contrate that meshes with a $\frac{1}{2}$ " Pinion 17 on the Rod that forms the central pivot about which the crane turns and which also transmits the drive from the gear box. The end of this Rod is journalled in the bore of a Coupling mounted loosely on the Rod 15a. Couplings 16 are employed in the place of Collars to prevent end play in the Rods 15 and 15a; if Collars

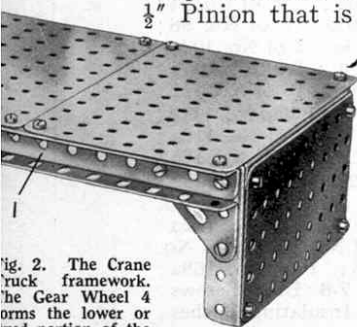

Fig. 2. The Crane Truck framework. The Gear Wheel 4 forms the lower or fixed portion of the tail Bearing unit.

were employed here their grub screws would foul the flanges of the Plates 6.

The two axles 15, 15a are connected together by means of a length of Sprocket Chain passing over 2" Sprocket Wheels secured to the axles. This arrangement ensures that the drive is distributed over all four wheels, thus obviating the possibility of wheel slip.

It will be noticed that the ends of the axles 15 and 15a are passed through the slotted holes of the Flat Girders 7 and are journalled in the Collars secured to the springs. The slots thus form guides which, while permitting the free vertical movement of the axles under the action of the springs, prevent any adverse side strain being applied to the springs.

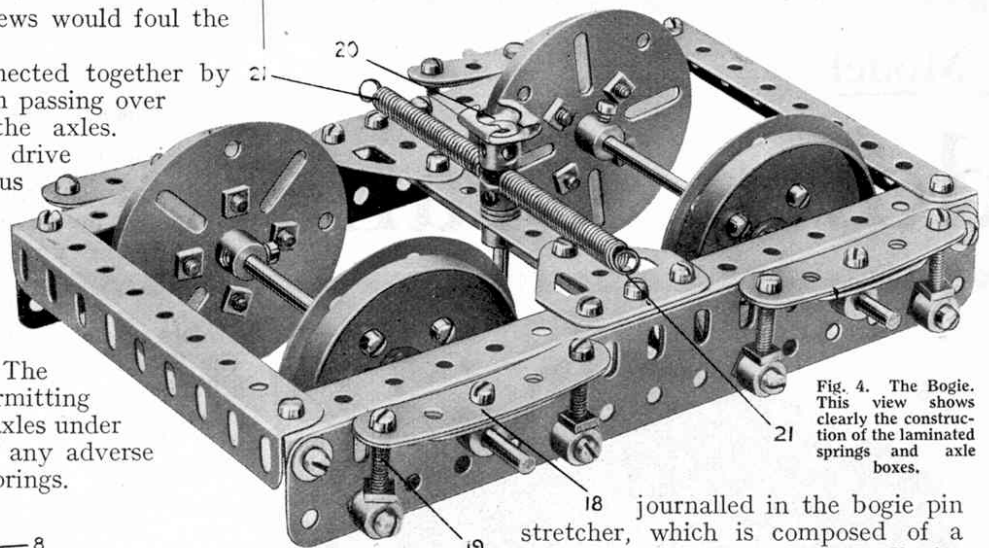
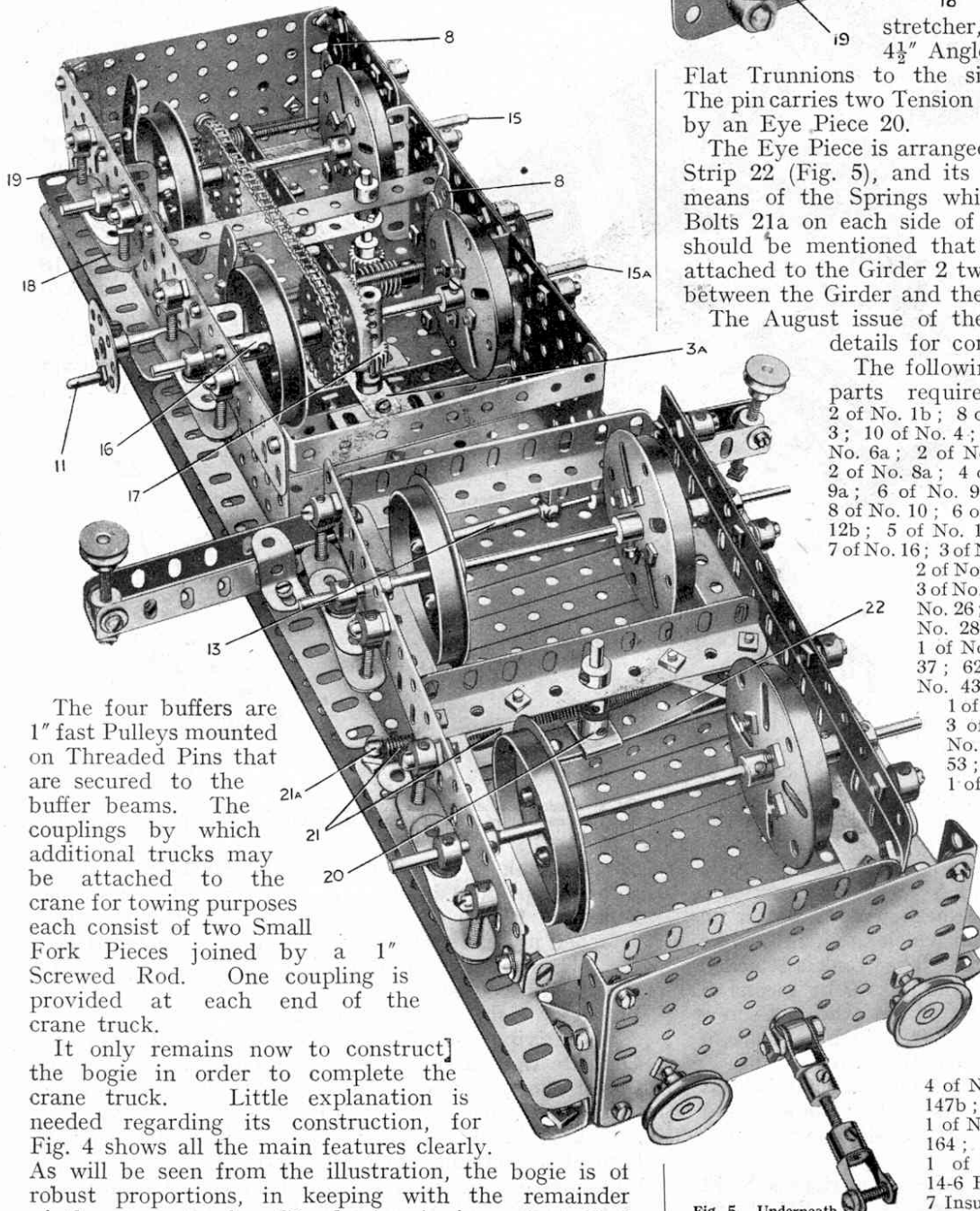

Fig. 4. The Bogie. This view shows clearly the construction of the laminated springs and axle boxes.



18 journalled in the bogie pin stretcher, which is composed of a 4½" Angle Girder secured rigidly by Flat Trunnions to the side Girders of the frame. The pin carries two Tension Springs 21 and is surmounted by an Eye Piece 20.

The Eye Piece is arranged to slide on the 5½" Curved Strip 22 (Fig. 5), and its movement is restrained by means of the Springs which are attached to the ¾" Bolts 21a on each side of the truck (see Fig. 5). It should be mentioned that when the Curved Strip is attached to the Girder 2 two Washers should be placed between the Girder and the Strip for spacing purposes.

The August issue of the "M.M." will contain full details for completing the model.

- The following is a complete list of the parts required to build the model.
- 2 of No. 1b; 8 of No. 2; 6 of No. 2a; 12 of No. 3; 10 of No. 4; 32 of No. 5; 15 of No. 6; 11 of No. 6a; 2 of No. 7; 6 of No. 7a; 2 of No. 8; 2 of No. 8a; 4 of No. 8b; 8 of No. 9; 8 of No. 9a; 6 of No. 9b; 4 of No. 9d; 2 of No. 9f; 8 of No. 10; 6 of No. 11; 10 of No. 12; 1 of No. 12b; 5 of No. 14; 1 of No. 15; 5 of No. 15a; 7 of No. 16; 3 of No. 16a; 3 of No. 17; 2 of No. 18a; 2 of No. 20b; 10 of No. 22; 5 of No. 22a; 3 of No. 23; 2 of No. 23a; 5 of No. 24; 9 of No. 26; 6 of No. 27a; 1 of No. 27b; 1 of No. 28; 1 of No. 29; 1 of No. 30a; 1 of No. 30c; 1 of No. 32; 342 of No. 37; 62 of No. 37a; 82 of No. 38; 2 of No. 43; 2 of No. 45; 1 of No. 47; 1 of No. 47a; 1 of No. 48; 1 of No. 48a; 3 of No. 48b; 2 of No. 48c; 1 of No. 50a; 11 of No. 52a; 4 of No. 53; 2 of No. 53a; 63 of No. 59; 1 of No. 62; 6 of No. 62b; 9 of No. 63; 2 of No. 64; 4 of No. 70; 4 of No. 72; 2 of No. 76; 2 of No. 77; 2 of No. 80a; 2 of No. 81; 2 of No. 82; 3 of No. 89; 6 of No. 90; 2 of No. 90a; 2 ft. of No. 94; 2 of No. 95a; 2 of No. 96; 2 of No. 96a; 2 of No. 103a; 2 of No. 103f; 2 of No. 103k; 8 of No. 109; 18 of No. 111; 24 of No. 111a; 6 of No. 111c; 9 of No. 115; 4 of No. 116a; 1 of No. 120a; 2 of No. 125; 4 of No. 126a; 2 of No. 133; 4 of No. 136; 8 of No. 137; 2 of No. 147b; 1 of No. 152; 1 of No. 162a; 1 of No. 162b; 2 of No. 163; 1 of No. 164; 1 of No. 166; 1 of No. 168a; 1 of No. 168b; 7-6 B.A. Screws; 14-6 B.A. Nuts; 7 Insulating Bushes; 7 Insulating Washers; 1 Terminal; 1 Electric Motor.

Fig. 5. Underneath view of Crane Truck.

The four buffers are 1" fast Pulleys mounted on Threaded Pins that are secured to the buffer beams. The couplings by which additional trucks may be attached to the crane for towing purposes each consist of two Small Fork Pieces joined by a 1" Screwed Rod. One coupling is provided at each end of the crane truck.

It only remains now to construct] the bogie in order to complete the crane truck. Little explanation is needed regarding its construction, for Fig. 4 shows all the main features clearly. As will be seen from the illustration, the bogie is of robust proportions, in keeping with the remainder of the crane truck. The bogie pin is a short Rod

New Meccano Model

Railway Breakdown Crane

Completion of Instructions for building this Fine Model

IN the first instalment of this article dealing with the construction of the Meccano Railway Breakdown Crane, which appeared last month, the construction of the crane truck and bogie was described, and providing our instructions were carefully followed the model-builder may now proceed with the remaining portions of the model, which include the superstructure, jib, gear box mechanism, and resistance controller for the Motor. Full details for dealing with each part are given in this article, together with instructions for the final assembly of the various units.

The next item of the model to receive consideration is the gear box and the base to which it is attached. The latter consists essentially of three $5\frac{1}{2}'' \times 3\frac{1}{2}''$ and one $5\frac{1}{2}'' \times 2\frac{1}{2}''$ Flat Plates bolted to two $12\frac{1}{2}''$ Angle Girders 23 (Figs. 6 and 7) the ends of which are spanned by $5\frac{1}{2}''$ Angle Girders.

The sides of the gear box consist of $5\frac{1}{2}'' \times 3\frac{1}{2}''$ Flat Plates 24 that are attached to the base by $5\frac{1}{2}''$ Angle Girders 25 (Fig. 7), $3\frac{1}{2}''$ Angle Girders being added to the front edges of the Plates for stiffening purposes. Two $2\frac{1}{2}''$ Triangular Plates 27 (Fig. 6) secured to these Girders will eventually form the bearings for the jib pivot pin.

The reinforced bearings for the vertical Rods carrying the $1\frac{1}{2}''$ Bevel 41 and $\frac{1}{2}''$ Pinion 43 (Fig. 7) should next be secured in place. The Flanged Ball Race forming the

upper portion of the Meccano Ball Bearing, on which the model turns, is fixed centrally under the latter bearing, being held in place by four $\frac{1}{2}''$ Bolts and spaced away from the underside of the superstructure by four Collars placed upon the bolts.

The gear box layout is remarkably simple, due to the employment of an entirely new principle in Meccano engineering. The chief advantage of this gear box is that none of the Axle Rods or Gears are required to slide transversely. Consequently the Gears may be engaged instantly on movement of a lever and they do not require the accurate placing on the Rods that is usually necessary with the ordinary type of gear box.

The Rod 30 (Figs. 6 and 7) is driven by the Motor through the medium of Sprocket Chain and forms the main

Fig. 6. General view of the Superstructure, with roof removed.

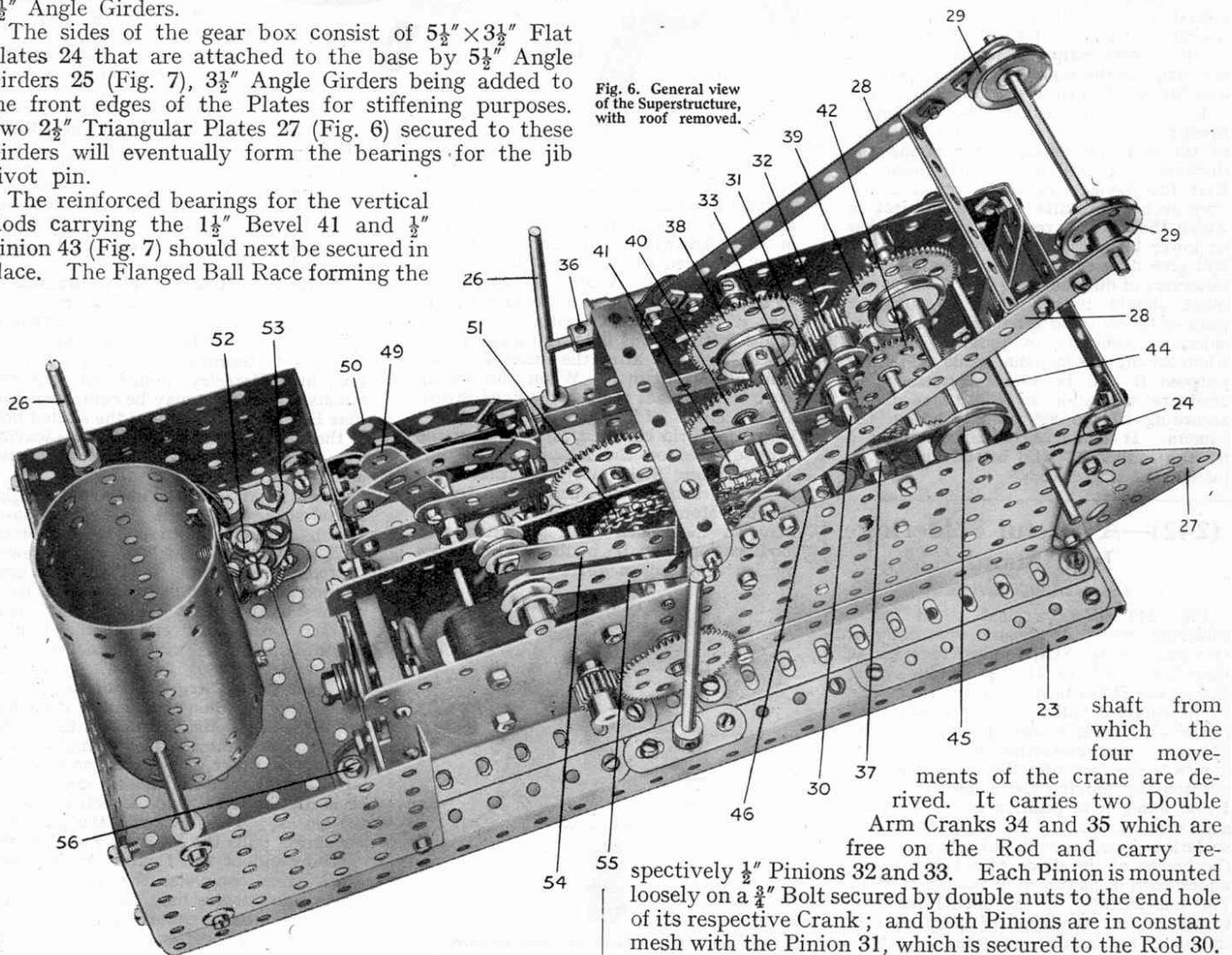

shaft from which the four movements of the crane are derived. It carries two Double Arm Cranks 34 and 35 which are free on the Rod and carry respectively $\frac{1}{2}''$ Pinions 32 and 33. Each Pinion is mounted loosely on a $\frac{3}{4}''$ Bolt secured by double nuts to the end hole of its respective Crank; and both Pinions are in constant mesh with the Pinion 31, which is secured to the Rod 30.

The 57-teeth Gears 38 and 39 are secured to the luffing and hoisting winch barrels respectively and by manipulating the lever 49 the Crank 34 is rocked backward or forward on its shaft and the Pinion 32 is brought into engagement with either of these Gears 38 or 39.

With regard to the travelling motion of the model, this is derived from the Rod on which a 57-teeth Gear 42 is secured. The Rod carries also a $\frac{3}{4}$ " Con-
trate that is in constant mesh with a $\frac{1}{2}$ " Pinion 43 secured on the top of the vertical Rod that forms the central pivot of the model and which has the Pinion 17 (see Fig. 5 in the July "M.M.") secured to its lower extremity. This vertical Rod, after passing through the Double Bent Strip and Plate in the base of the super-
structure, is journalled freely in the Flanged Ball Race that is bolted directly underneath the Plate. The Rod also is free to turn in the boss of the Gear 4.

The slewing movement is obtained as follows: A 57-teeth Gear 40 is secured to a Rod carrying also a $\frac{1}{2}$ " Bevel in mesh with a Bevel 41. This Bevel is fixed to a short Rod carrying at its bottom end a $\frac{1}{2}$ " Pinion that will mesh with the Gear 4 (Fig. 2 July "M.M."), which forms part of the Ball Bearing (see Standard Mechanisms No. 144). Both the Rods carrying the Pinion 43 and the Bevel 41 are journalled in the reinforced bearings mentioned previously, and the four Rods on which the Gears 38, 39, 40 and 42 are secured, are journalled in the side Plates of the gear box and are restrained from lateral movement by Collars.

By moving the lever 50 either the travelling or slewing movements of the model may be brought into action and if desired either the luffing or hoisting motions may be used at the same time.

The construction of the lever frame will be clear on reference to Fig. 7. The $2\frac{1}{2}$ " Strips 49 and 50, forming the levers proper, are pivoted in their bottom holes on a Rod that is carried in two $2\frac{1}{2}$ " Strips forming part of the frame. The $5\frac{1}{2}$ " Strips 47 and 48 form the connecting links between the levers and their respective Double Arm Cranks, the connections being made by lock-nutted bolts. In order to lock the lever 49 in either hoisting, luffing or neutral positions and the lever 50 in either travelling, slewing or neutral positions, round-headed Bolts 49a are bolted on the second hole of each lever so that their rounded heads engage with holes in the quadrants after each movement of the levers. The latter should, of course, be spaced on their pivot rod so that the bolts are pressed firmly against the quadrants.

The Motor gearing is arranged as follows: A $\frac{1}{2}$ " Pinion on the armature spindle meshes with a 57-teeth Gear

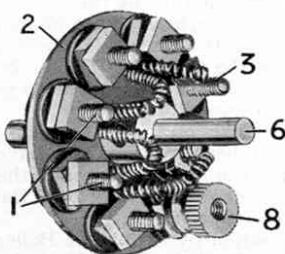

Fig. 8. Underneath view of the Controller Unit showing the resistances.

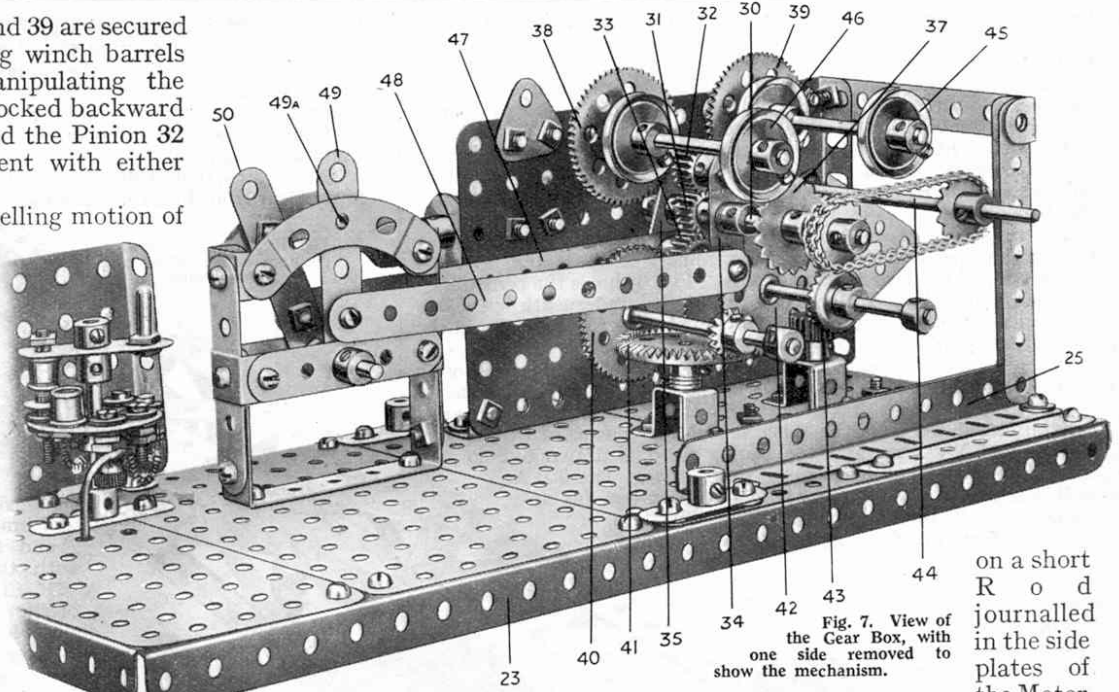

Fig. 7. View of the Gear Box, with one side removed to show the mechanism.

on a short Rod journalled in the side plates of the Motor,

and this Rod also carries a second $\frac{1}{2}$ " Pinion that engages with a 57-teeth Gear on another Rod that is vertically above the first. This Rod has a 1" Sprocket 51 secured to it. The Motor may now be bolted down in the position indicated in Fig. 6 and the Sprocket 37 on the main shaft 30 connected with that on the Motor by a length of Sprocket Chain. The 1" fast Pulleys 45 and 46 on the hoisting and luffing winch barrels comprise the brake drums. A length of cord is wrapped round each Pulley, one end being fastened to a suitable part of the framework and the other to the appropriate brake lever 54 or 55 (Fig. 6). These levers consist of 3" Strips attached pivotally to a Single Bent Strip that is bolted to a $3\frac{1}{2}$ " Double Angle Strip spanning the sides of the gear box. The extremities of the brake levers are weighted with $\frac{1}{2}$ " fast Pulleys in order to maintain the cord in a slight state of tension round the brake drums, and thus prevent the load or the jib descending when the barrels are thrown out of gear.

Having assembled the mechanism, two Strips 28 may be attached pivotally to 1" Triangular Plates that are bolted to the gear box side Plates. The ends of the Strips are spaced apart by a $3" \times 1\frac{1}{2}"$ Double Angle Strip and a $3\frac{1}{2}"$ Rod journalled in the extreme end holes carries the Pulleys 29.

The cylinder 36 (Fig. 6) gives additional realism to the model. It consists of a Sleeve Piece with two $\frac{3}{4}"$ Flanged Wheels forming the cylinder covers through which the piston rod passes. An End Bearing on the end of the latter is attached pivotally to the connecting rod, the other end of which is pivoted by a lock-nutted bolt to the crank disc. The crank disc consists of a Bush Wheel, and is secured on the Rod 44 (Figs. 6 and 7), which is driven from the main shaft 30 through the medium of a length of Sprocket Chain passing over $\frac{3}{4}"$ Sprocket Wheels. The appearance of the cylinder, etc., will be gathered from the general view of the model.

The boiler is attached to a $5\frac{1}{2}" \times 2\frac{1}{2}"$ Flat Plate that

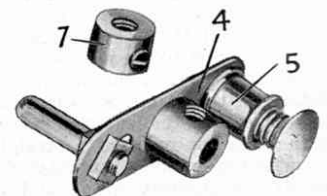

Fig. 9. Detail view of the Controller Switch Arm.

forms part of the coal bunker, the sides of which are formed from $3\frac{1}{2} \times 2\frac{1}{2}$ Flanged Plates. Rods 26 are secured to the Flanged Plates by means of Collars, the purpose of the Rods being to form supports for the roof. Two further Rods 26 are needed for this purpose and they are inserted in Double Arm Cranks that are secured to the base in the positions indicated in Fig. 6.

The boiler fittings include a pressure gauge, represented by a $\frac{1}{2}$ " loose Pulley, and a water gauge 52 composed of a $1\frac{1}{2}$ " Rod secured in two Handrail Supports and attached to the front of the boiler.

The resistance controller 53 (Fig. 6), the function of which is to alter the speed of the Motor, is extremely compact and is built entirely from standard Meccano parts. Fig. 6 shows the controller in place whilst Fig. 8 gives an idea of the underneath view of the device with the resistance elements in place. Fig. 9 is a detailed view of the switch arm and spring contact.

The resistance elements consist of a short length of Spring Cord that is attached at equal distances to the shanks of 6 B.A. Bolts 1 (Fig. 8), one of which carries a terminal 8. The 6 B.A. Bolts are carefully insulated from the Bush Wheel 2 by means of Insulating Bushes and Washers, and the Spring Cord is drawn out so that no two adjacent turns touch each other. The 6 B.A. Bolt 3 is insulated in the usual manner but remains unconnected; it thus forms the "off" position of the controller, in which no current is supplied to the Motor.

The switch arm (Fig. 9) consists of a Double Arm Crank 4 carrying a Spring Buffer 5, the head of which presses on the heads of the 6 B.A. Bolts forming the "contact studs"; thus smooth and efficient contact with the studs is assured. The Crank pivots on the top end of the supporting Rod 6 and is retained in position by the Collar 7. A Threaded Pin on the other

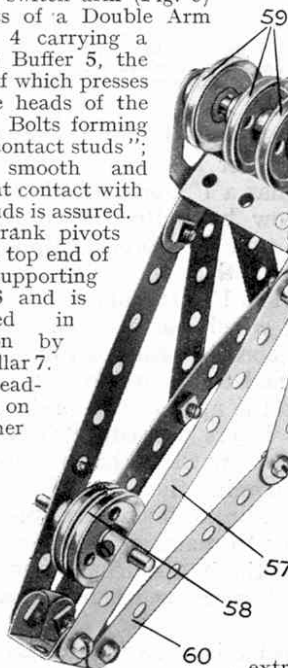

Fig. 11. Underneath view of the Roof, removed from the superstructure.

extremity of the switch arm forms a convenient handle. In order to prevent the switch arm riding off the contact studs at either extremity of its travel, a stop consisting of the socket portion of a Spring Buffer, is secured to the Bush Wheel 2.

One of the Motor terminals is "earthed" to the frame of the model by connecting it to the bolt 56 (Fig. 6) by a short length of wire. The other terminal of the Motor is connected to the 6-volt Accumulator or Transformer by a length of wire, which passes out of the rear of the model. The other lead from the Accumulator is connected to the terminal 8 of the controller.

When the spring contact 5 (Fig. 9) of the switch arm is pressing on the "off" stud 3, no current is supplied to the Motor, of course. But when the switch arm is moved on to the next stud, the Motor commences to revolve at a slow rate of speed, due to the fact that the current has to flow through the entire resistance and that its value is therefore small. (Actually it is the voltage that is "dropped" or expended in the resistance. This causes the current to drop too, for voltage is the "driving force" or pressure forcing current through the resistance of a circuit.)

On moving on to the next stud, one stage of the resistance is cut out and the speed of the Motor increases. Step by step, as more resistance is taken out, the speed of the Motor mounts up until the switch arm is on the last stud carrying the terminal 8, when all the resistance is cut out and a straight-through path is afforded for the current from the Accumulator to the Motor. The Motor now runs at its greatest speed and develops its maximum power.

The underside of the roof is shown in Fig. 11. It consists essentially of one $5\frac{1}{2} \times 3\frac{1}{2}$ and two $5\frac{1}{2} \times 2\frac{1}{2}$ Flat Plates, to the

edges of which Strips are added for the purpose of stiffening. Four Couplings are secured by means of bolts to each corner of the roof to receive the top ends of the supporting Rods (Fig. 6). A Boiler End is secured to the underside of the roof by a single bolt, which also retains a Chimney Adaptor in place on the reverse side of the roof and a Sleeve Piece to represent a chimney is fitted over the Chimney Adaptor.

The construction of the jib should be fairly clear from Fig. 10. The four

Fig. 10. The Jib, showing positions of the luffing and hoisting Pulleys.

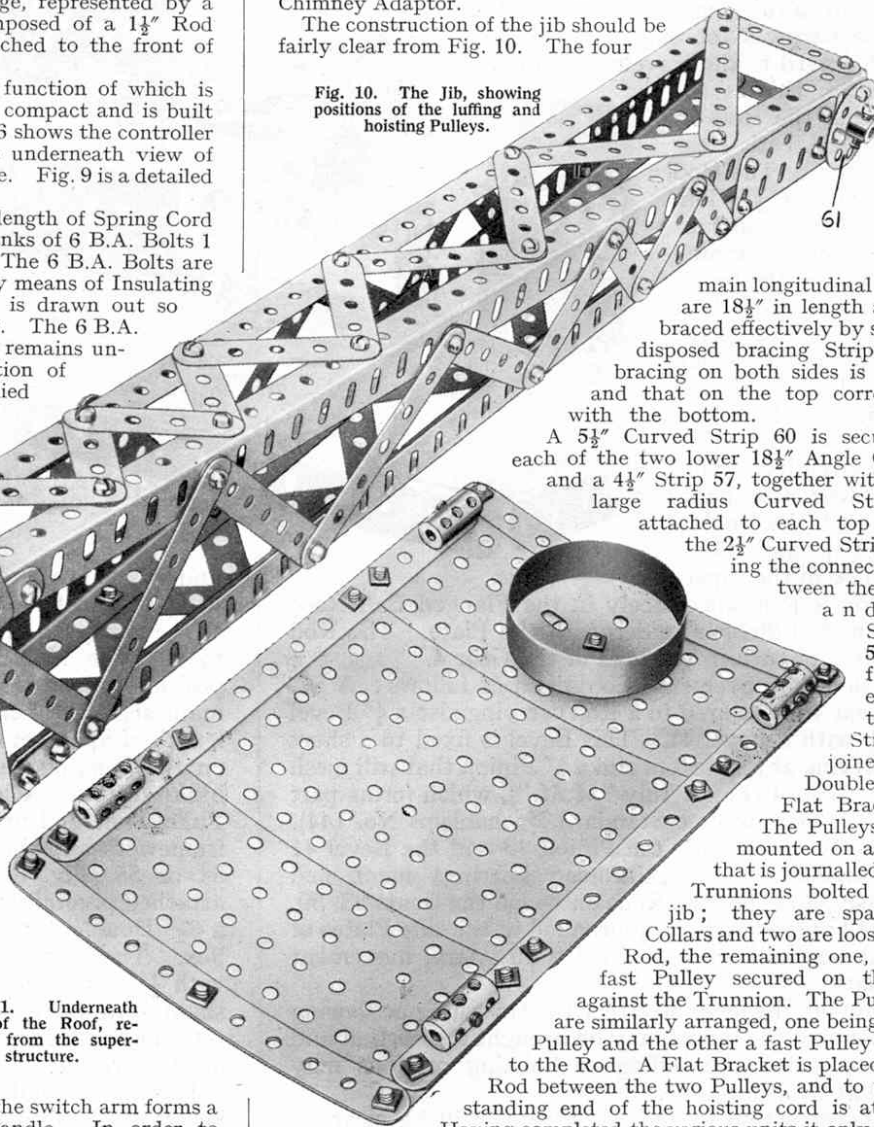

main longitudinal Girders are $18\frac{1}{2}$ " in length and are braced effectively by suitably disposed bracing Strips. The bracing on both sides is similar, and that on the top corresponds with the bottom.

A $5\frac{1}{2}$ " Curved Strip 60 is secured to each of the two lower $18\frac{1}{2}$ " Angle Girders, and a $4\frac{1}{2}$ " Strip 57, together with a $2\frac{1}{2}$ " large radius Curved Strip, is attached to each top girder, the $2\frac{1}{2}$ " Curved Strip forming the connection between the Girder and the Strip 57. The front ends of the Strips are joined by Double and Flat Brackets.

The Pulleys 59 are mounted on a 2" Rod that is journaled in Flat Trunnions bolted to the jib; they are spaced by Collars and two are loose on the Rod, the remaining one, being a fast Pulley secured on the Rod against the Trunnion. The Pulleys 58 are similarly arranged, one being a loose Pulley and the other a fast Pulley secured to the Rod. A Flat Bracket is placed on the Rod between the two Pulleys, and to this the standing end of the hoisting cord is attached. Having completed the various units it only remains to assemble them into a complete model.

The swivelling superstructure is lowered into place over the central pivot (i.e., the Rod transmitting the drive to the travelling wheels) care being taken that the Ball Casing containing the balls is first placed in position on the $3\frac{1}{2}$ " Gear 4 (Fig. 2, July "M.M."), and that it registers correctly with the Flanged Ball Race which is bolted to the underside of the superstructure. It should also be seen that the $\frac{1}{2}$ " Pinion on the lower end of the Rod carrying the Bevel 41 is meshing properly with the teeth of the Gear 4. The Pinion 17 (Fig. 5, July "M.M.") may now be secured to its Rod.

The jib pivot pin—a $4\frac{1}{2}$ " Rod—is passed through the $2\frac{1}{2}$ " Triangular Plates 27 (Fig. 6) and through the bosses of the Bush Wheels 61 (Fig. 10) that are secured to the foot of the jib.

One end of the luffing cord is attached to the head of the jib and passed over one of the Pulleys 29 (Fig. 6). It is then taken over a Pulley 59 at the jib head and back over the remaining Pulley 29. Thence it is led over the other Pulley 59 at the jib head and down to the luffing winch barrel, on which it is secured.

The hoisting cord is secured to a Flat Bracket on the Rod carrying the Pulleys 58 and passed round one of the sheaves of the two sheave Pulley Block. Next it passes over one of the Pulleys 58, round the remaining sheave of the Block, over the other Pulley 58, over the centre Pulley 59, and so down to the hoisting barrel.

Finally the roof may be placed in position by fitting the Boiler End on to the Boiler and securing the ends of the Rods 26 in the centre transverse bores of the Couplings that are secured to the underside of the roof.