

# Spinning Wheel

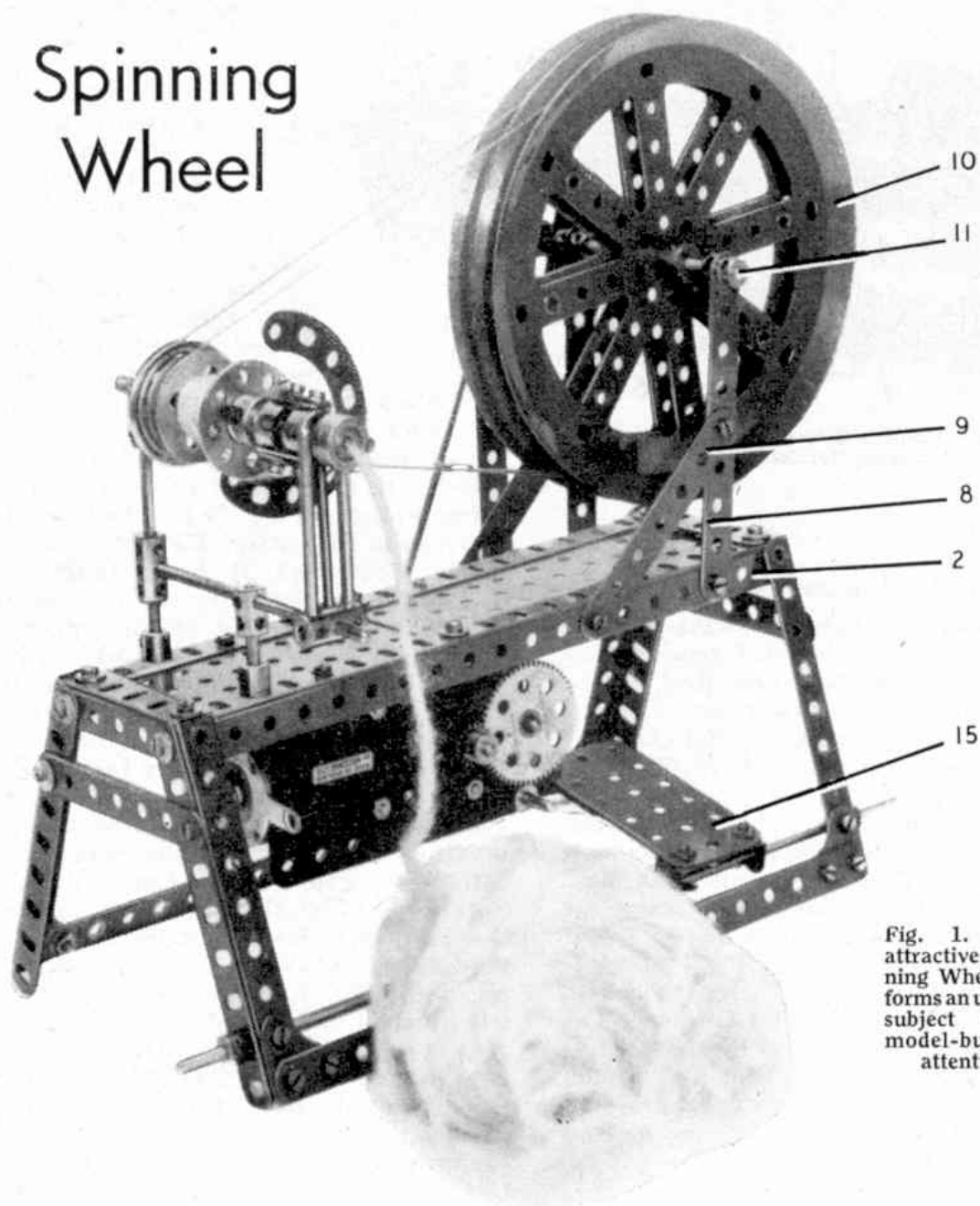

Fig. 1. An attractive Spinning Wheel that forms an unusual subject for a model-builder's attention.

## An Unusual New Model

THE rectangular table of the Spinning Wheel shown in Figs. 1, 2 and 3 is built from two  $9\frac{1}{2}$ " Angle Girders 1 and 2, and two  $2\frac{1}{2}$ " Angle Girders 3 and 4, and is filled in with a  $5\frac{1}{2} \times 2\frac{1}{2}$ " and a  $4\frac{1}{2} \times 2\frac{1}{2}$ " Flat Plate. At each corner a  $4\frac{1}{2}$ " Angle Girder 5 is bolted, braced by a  $3\frac{1}{2}$ " Strip 6 and joined at the lower ends by  $9\frac{1}{2}$ " Strips 7, the latter having 1" Corner Brackets to give extra support.

The Spinning Wheel bearings are  $4\frac{1}{2}$ " Strips 8 braced by  $3\frac{1}{2}$ " Strips 9 bolted to the Angle Girders 1 and 2.

Two 6" Pulley Wheels 10 are placed on a

$4\frac{1}{2}$ " Rod 11 held in place with Collars. A 2" Pulley Wheel and a Crank 12 are also fixed to the Rod. A  $6\frac{1}{2}$ " compound Strip is lock-nutted to the Crank at one end and to an Angle Bracket 13 at the other, and this in turn is lock-nutted to another Angle Bracket 14 bolted to a 3" Strip attached to a  $2\frac{1}{2} \times 1\frac{1}{2}$ " Plate 15. Next, a  $1\frac{1}{2} \times \frac{1}{2}$ " Double Angle Strip is bolted to the Plate, which pivots on a  $11\frac{1}{2}$ " Rod supported in the Angle Girders 5.

An E15R Electric Motor is bolted to the Angle Girders 1 and 2. A  $\frac{1}{2}$ " Pinion on its armature shaft drives a 57-tooth Gear

Wheel, on the Rod of which is also a  $\frac{7}{16}$ " Pinion that drives a 60-tooth Gear Wheel. The 1" Pulley is connected to the 2" Pulley with a 15" Driving Band.

On a 3" Rod 16 a  $1\frac{1}{2}$ " Pulley 17 is fixed. A Bush Wheel 18 and a  $1\frac{1}{8}$ " Flanged Wheel 19 are secured in a Socket Coupling 20, which is placed loosely on Rod 16 and held clear of the  $1\frac{1}{2}$ " Pulley by means of a Collar.

Two Socket Couplings 21 and 22 are joined together with two Fishplates, Washers being used on the bolt shanks so that the bolts do not foul the Collars inserted in each end of the Socket Couplings. *The Collars in the Socket Coupling 21 are fixed to the Rod 16. The Collars in Socket Coupling 22 are held with Grub Screws forming a hollow shaft.*

Two  $2\frac{1}{2}$ " Stepped Curved Strips 23 are held in place by two nuts on a  $\frac{3}{4}$ " Bolt 24 that is fastened in the Socket Coupling with a Nut and Washer. This entire unit is mounted loosely on a Rod journalled in Coupling 25 and the Bearing 26, which is made from two  $2\frac{1}{2}$ " Rods and a 2" Screwed Rod fixed in Coupling 27. Two Rod Sockets are fixed to the Angle Girders 1 and 2, and carry 1" Rods on which are mounted a Coupling and a Short Coupling. A  $3\frac{1}{2}$ " Rod 28 passes through these as shown. The Coupling also holds a  $1\frac{1}{2}$ " Rod and the Coupling 25. *The Rod 16 must rotate very freely.* A length of cord is used to connect one of the 6" Pulleys to the  $1\frac{1}{2}$ " Pulley, and a further length of cord connects the other 6" Pulley to the Flanged Wheel.

To get the Wheel ready for working unspun wool is threaded through both Collars in the Socket Coupling 22, through the end hole of one of the Curved Strips 23, and fastened to the Socket Coupling 20.

The correct material for use with this model is raw wool, and small supplies of this can usually be collected from barbed wire fences in fields where sheep have been grazing. Alternatively, you might be able to persuade a farmer to give you a handful or two from a fleece. *Ordinary cotton will not do*, but the kind used by chiropodists will be satisfactory.

Before the wool can be spun it must be

"teased" with the fingers, pulling the wool out from its matted state, and afterwards "carded".

For carding, a pair of "cards" is needed. These are two flat pieces of wood with handles, like table tennis bats, only square. If possible the wood should be covered on one side with leather, or leathercloth, into which is inserted over the whole surface bent wires turning towards the handle.

Take one card in your left hand, placing it on your lap with the wires uppermost and the handle pointing to the left. On this you place a small portion of wool. Now, with the other card in the right hand, the handle pointing to the right, you draw this several times across the left card until almost all the wool is on the right-hand card. This is then returned to the left-hand card by turning this card and pointing both handles towards you, then pushing the right-hand card across the other. This process is repeated several times, and then the wool

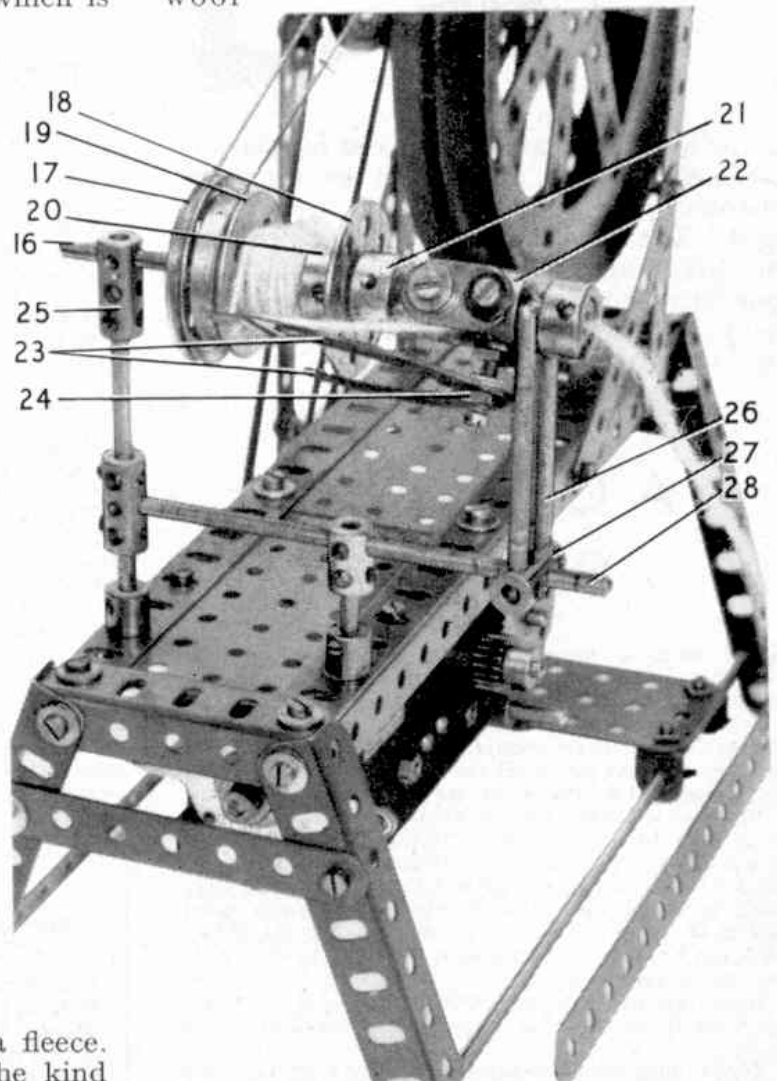
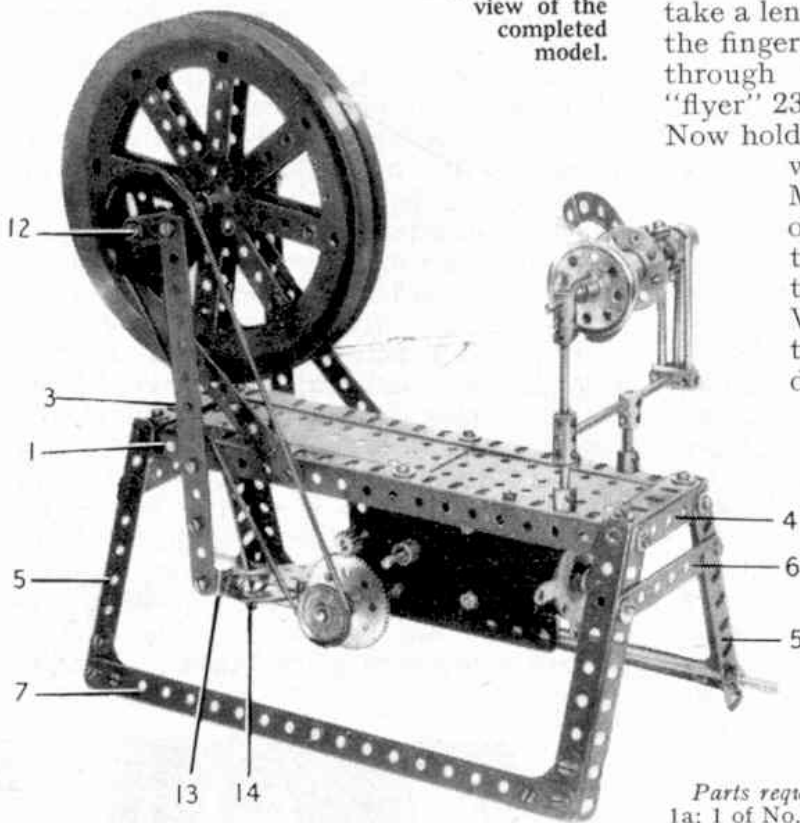

Fig. 2. A close-up of the "mechanism" of the Spinning Wheel.

Fig. 3. Another view of the completed model.



on the left-hand card is removed by placing the cards at right angles and scraping the left-hand card down across the edge of the right. The wool is now lifted, by drawing the left-hand card lightly upwards, and then dropped on to the back of the right-hand card, where it is rolled between the two card backs into a neat roll.

Now the actual spinning may be started: take a length of the roll, twisting it between the fingers to form a thread, and thread it through the Socket Coupling 22, the "flyer" 23, and then tie it to the bobbin 20. Now hold the wool near the spindle lightly with the left hand, and start the Motor. With the right hand, draw out a few inches of fleece, relax the hold of the left hand, and let the yarn run on to the bobbin. With practice it becomes possible to expose a longer stretch of drawn-out fleece, and a delightfully rhythmical movement results as the right hand moves first from, and then towards, the left.

You may practice by twisting together two threads of two-ply wool of different colours to get the idea of obtaining even twist. When doing this it is better to run the spindle *anti-clockwise*, and *clockwise* when using wool.

*Parts required to build the Spinning Wheel:* 2 of No. 1a; 1 of No. 2; 2 of No. 2a; 4 of No. 3; 2 of No. 4; 1 of No. 5; 2 of No. 8a; 4 of No. 9a; 2 of No. 9d; 2 of No. 10; 2 of No. 12; 1 of No. 13; 1 of No. 15a; 1 of No. 15b; 2 of No. 16; 3 of No. 16a; 1 of No. 17; 2 of No. 18b; 2 of No. 19c; 1 of No. 20; 1 of No. 20a; 1 of No. 21; 1 of No. 22; 1 of No. 24; 1 of No. 26; 1 of No. 26c; 1 of No. 27a; 1 of No. 27d; 2 of No. 35; 50 of No. 37a; 45 of No. 37b; 24 of No. 38; 1 of No. 48a; 1 of No. 53a; 9 of No. 59; 1 of No. 62; 3 of No. 63; 1 of No. 63d; 1 of No. 70; 1 of No. 73; 2 of No. 81; 2 of No. 90a; 1 of No. 111; 3 of No. 111c; 4 of No. 133a; 3 of No. 171; 2 of No. 179; 1 of No. 186d; 1 E15R Electric Motor.

## A Competition Reminder

WE wish to remind all Meccano model-builders that there is still time to prepare and send in entries for the "Winter Model-Building Competition", of which details were given in last month's *M.M.* In this Contest every competitor, no matter what his age may be, has an equal chance of winning a prize, and it does not matter what size of Outfit he possesses.

All that a reader has to do is to think of a new model and then to set to work to construct it as neatly and realistically as possible from standard Meccano parts. When he has completed this model, the next thing is to obtain either a photograph or a good sketch of it, and send this to us. The actual model must not be sent. If a photograph cannot be obtained, and an entrant is not good at sketching, he can ask a friend to make a sketch of the model for him, provided of course that the model itself is his own work.

The Competition is open to readers of all ages living in any part of the world, and will be divided into two Sections, as follows: A, for competitors under 14 years of age; B, for competitors aged 14 years

or over. A separate set of prizes, as announced in the accompanying panel on this page, will be awarded in each Section.

The judges will award the prizes for those models that are the most original in subject, well proportioned and built on correct mechanical principles.

Choose any subject you like for your model, but be careful to select one that you can reproduce realistically with the Outfit you possess. It will also help you on the way to success if you choose a model that "works".

Before posting your entry write your age, name and address on the back of each photograph or drawing. Address the envelope "Winter Model-Building Competition, Meccano Ltd., Binns Road, Liverpool 13." Closing date: 31st May next.

### THE PRIZES

The following prizes will be awarded in each of the Sections A and B:

First Prize, cheque for .. ..	£4 4 0
Second Prize, cheque for .. ..	£2 2 0
Third Prize, cheque for .. ..	£1 1 0
Five Prizes each of 10s. 6d.	
Five Prizes each of 5s. 0d.	

Certificates of Merit also will be awarded.