

# Steering a Motor Car

A Meccano Demonstration of the Mechanical Principles Involved

By Edgar Wright

*This article describes not only the more important mechanical principles involved in steering a motor car, but also a Meccano model that clearly demonstrates the working of Ackermann steering gear. The model is quite simple to construct and is so designed that it may be incorporated without alteration in the existing Meccano motor chassis (Model No. 701).*

THE design of motor car steering gear is not nearly as simple as it may seem to the casual observer.

Many people appear to think that it is only necessary to twist the front axle round upon a pivot and the car will promptly describe a graceful curve or take sharp turns to right or left at the bidding of the driver. This idea of course is very far from the truth. In designing a car a great deal of care is given to this important part of the control, and there are many variations in the different steering gears in use at the present time.

Every steering gear, however, must fulfil three very important requirements, which may be briefly dealt with here.

First, it is necessary that there should be as little play as possible between the road wheels and the steering wheel—that is to say, the smallest movement of the steering wheel should produce almost instantaneous movement of the road wheels. On the other hand, allowance must be made for small irresponsible movements of the road wheels themselves. These movements are due to surface inequalities in the road, and must not transmit undue shocks or vibrations to the hands of the driver.

Second, after a car turns a corner the wheels should tend of their own accord to return to the straight. The rear driving wheels naturally tend to travel in a straight line and in a well-built car this tendency can usually be relied upon to bring the front wheels back to their normal position. In this connection it should be stated, however, that many conflicting opinions have been held in the past on the subject of "irreversibility" of steering gear.

## The "Irreversible" Control

The "irreversible" type of control is that in which the steering wheel can easily turn the front wheels, but the latter can with difficulty turn the steering wheel. This result is effected by worm gearing fitted between the steering wheel and the linkage and the degree of irreversibility obtained depends on the pitch of the worm.

It has been decided that the completely irreversible steering gear is not satisfactory, because the steering

wheel becomes "dead" and the driver loses his "feel" of the road. In addition, great stresses are introduced in the linkage, for every shock to the front wheels is opposed by a completely rigid mechanism.

Owners of Meccano outfits will understand these points better if they construct the Meccano model of a motor chassis and experiment with different types of steering gear. For example, if worm gearing is used between the steering column and the transverse shaft that conveys movement to the front stub axles, it will be found that,

while the wheels can be turned quite easily by the steering wheel, their position cannot be altered by grasping the wheels themselves with the intention of turning their axles about the pivots. The pitch of the Meccano Worm is so small that the gear is completely irreversible.

But suppose we substitute for the worm gear a Pinion and Contrate Wheel. The road wheels can now be moved either by turning the steering wheel or by touching the wheels themselves. In practice the "reversibility" of such a steering gear would be too great; the road wheels would be deflected by the smallest shock or bump, and the steering wheel would be difficult to hold while the car turned a corner. Therefore a happy medium between these two results is obtained by employing a worm of moderately large pitch. The greater portion of any shock to the wheels

is then absorbed in friction, but a slight tendency to twist is imparted through the pinion and worm to the steering wheel. Such a compromise in the gear arrangement also allows the wheels to "straighten out" if the wheel is released after the car has turned a corner. At the same time the wheel is not difficult to hold while the car is actually cornering.

## What Happens when Turning

Third, and this is an important point—the wheels must not remain parallel when negotiating a curve. Many readers may not have given much consideration to this point—indeed, some may not have given it even a thought, but a reference to Fig. 1 should make the

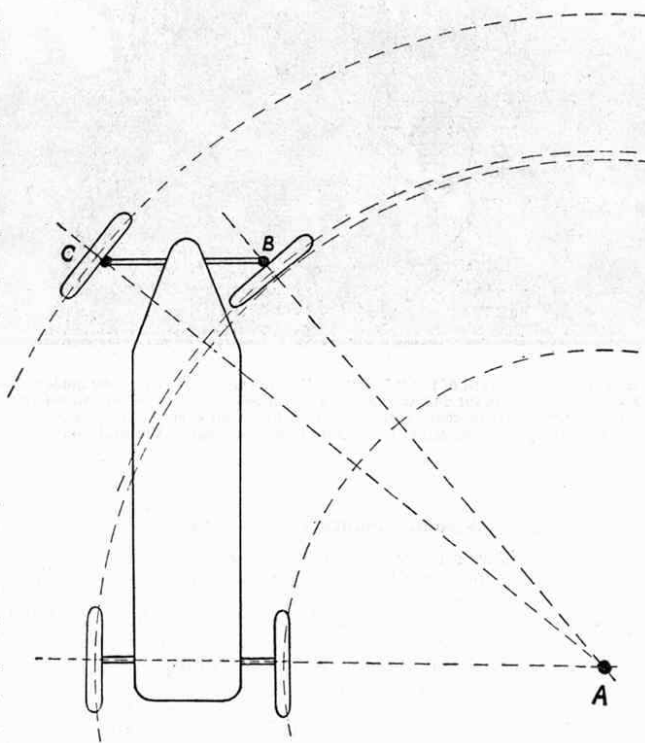

Fig. 1

statement clear.

The drawing is intended to represent a car turning a corner, and in doing so it will be apparent that the wheels must describe an arc or portion of a circle whose centre point is shown at A. Now although both front wheels must turn about this centre, they are situated at varying distances from it. This means to say that the right hand front road wheel must follow an arc of a circle having a radius equal to A B, and the left hand wheel must follow an arc of a circle with the least possible friction on the road surface each must be situated at a tangent to its respective circle. But it is obvious that both wheels cannot lie at their respective tangents and at the same time remain parallel with each other.

Hence it becomes necessary to incorporate in the steering gear some method by means of which a greater angle can be given to the wheel nearer the centre of the circle, whether the car be turning to right or left.

The principle by which this object is achieved is known as Ackermann steering. This interesting apparatus can be reproduced perfectly in Meccano, and its operation should

be made clear by reference to Figs. 2 and 3. The model shown therein is designed for incorporation in the Meccano motor chassis (Model No. 701 in the Meccano Complete Manual). Fig. 3 is a plan view of the fixed front axle and stub axle mountings, while Fig. 2 is a general view of the complete steering gear. Two short levers, 1 and 2, are rigidly connected to the stub axles. In practice these levers may project either forward or backward; in the model they project backward or *behind* the road wheels. They are connected one to the other by the tie rod 3.

**Principle of Ackermann Steering**

It will be noticed that the levers 1 and 2 lie at a

slightly obtuse angle to the stub axles (see Fig. 3). This angularity is most important, for on it rests the whole principle of Ackermann steering. The correct angle for the levers is arrived at by placing them so that their centre lines, if produced, would meet on the centre line of the car. The exact meeting place varies according

to the proportions of the car and length of the levers, but as a rule it is found to be just in front of the back axle.

Now if the car is to be turned to the right the road wheel 4 (Fig. 3) must be deflected in that direction and the lever 2 will be moved through a certain number of degrees to the left. In doing so it pushes the lever 1 in the same direction but owing to the difference in angularity between the two levers, lever 1 (and therefore the road wheel 5), moves through a lesser number of degrees. If the car moves to the left, exactly the opposite occurs, the lever 1 moving through a greater number of degrees than the lever 2.

Therefore this arrangement of the linkage fulfils the third requirement of the steering gear, that is, it imparts a greater angular movement to the inner road wheel when the car turns to right or left. As a matter of fact Ackermann gear does not fulfil all the requirements of the

ideal steering gear, for when it is used the outer wheel is turned a trifle too much at "small lock" (that is slight deviation from the straight). The error diminishes however until at a certain angle of the wheels the steering is perfect, but at still greater lock the inner wheel is turned a little too far in proportion to the angle of the outer wheel.

We now come to the design of the gearing between the steering wheel and the road wheels. The gear ratio, or extent of movement of the road wheels to a given movement of the steering wheel depends largely on the particular type of car. If the ratio is too high, however, a slight twist of the wheel will result in a considerable

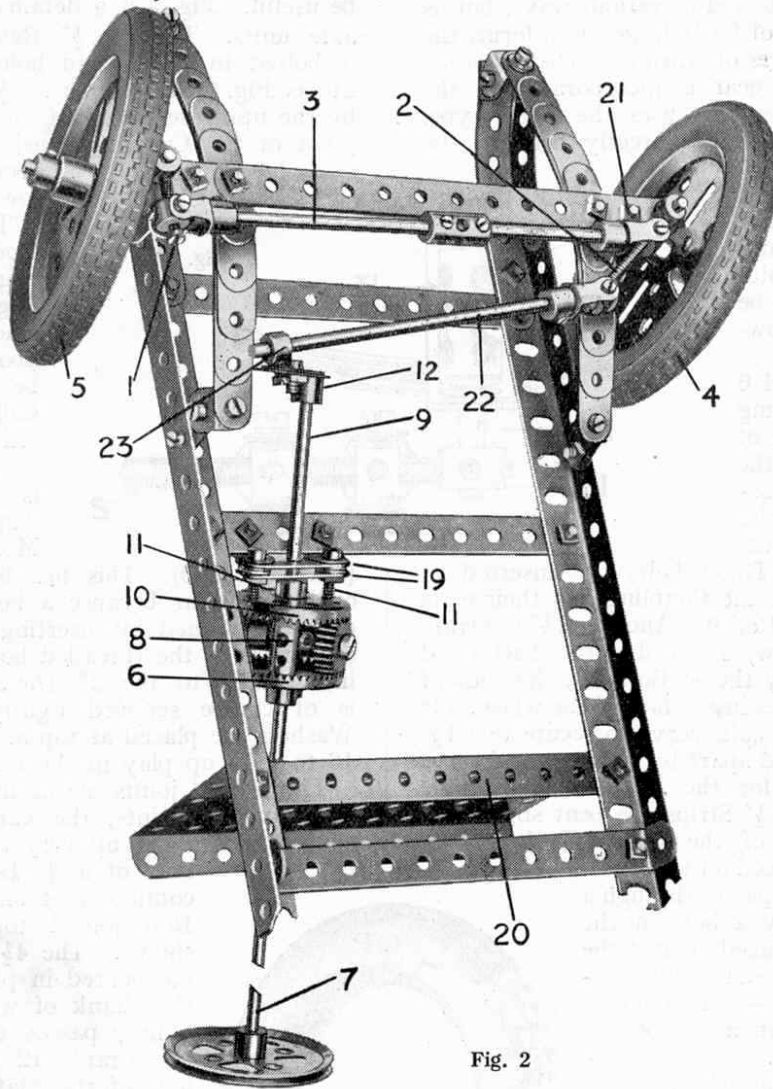

Fig. 2

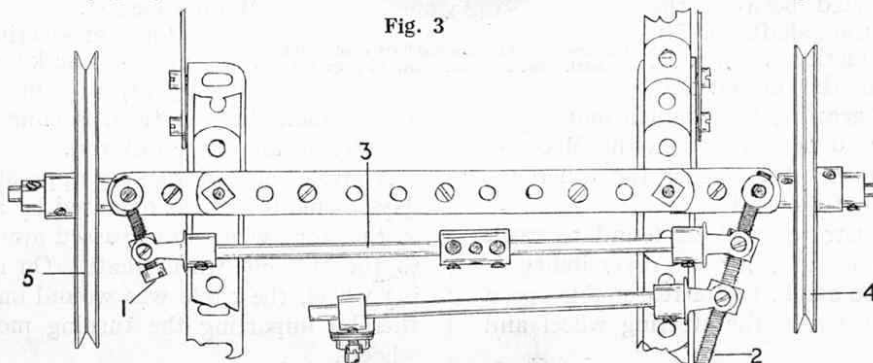

Fig. 3

deflection of the car which would be dangerous and might easily cause accidents. On the other hand, if the ratio is too low the car would be slow to respond to the wheel and therefore difficult to manage in dense traffic.

### Epicyclic Reduction Gear

The gear reduction is effected in various ways, but as already indicated a worm of fairly large pitch forms the basis of the more usual types of gearing. In some cars a small epicyclic reduction gear is incorporated in the steering column. The Ford car uses the latter type, the gear casing being mounted directly beneath the steering wheel.

The reduction gear adopted in the Meccano model is based on the epicyclic principle, and to make its operation quite clear the photograph may be supplemented by the following brief explanations:—

The  $1\frac{1}{2}$ " Contrate Wheel 6 is bolted rigidly to the steering post 7, the extreme end of which is free to rotate in the Coupling 8. The latter is secured to a 3" Rod 9 and carries two 25-teeth Pinions journalled on Pivot Bolts. These bolts are inserted in opposite threaded holes of the Coupling and their ends grip the extremity of the Rod 9. Another  $1\frac{1}{2}$ " Contrate Wheel 10 (without set-screw) is placed on the shaft 9 and prevented from turning by the  $\frac{1}{2}$ " Bolts 11, the ends of which enter two of the holes in the face of the wheel. It will be noticed that these bolts serve to secure two  $1\frac{1}{2}$ " Strips 19, which are spaced apart by Washers and serve as a reinforced bearing for the Rod 9. The Angle Brackets supporting the  $1\frac{1}{2}$ " Strips are bent slightly to conform with the angle of the steering column. A Collar and set-screw is placed on the steering post 7 where the latter passes through a further bearing, formed by a hole in the plate 20. The Collar is placed against the inner side of the bearing—i.e., the side nearest the Contrate Wheel 6—and so serves to hold the various components of the reduction gear in position.

Rotation of the steering wheel causes the  $\frac{3}{4}$ " Pinions to roll round the teeth of the fixed Contrate Wheel 10, and the movement of the Pinions imparts motion, in turn, to the Coupling 8 secured to the Rod 9 (which carries the steering drop lever 12, consisting of a Meccano Crank reinforced by a Flat Bracket). With this particular gearing a reduction ratio of one in two is obtained between the steering wheel and the shaft 9. In actual practice the reduction is greater, owing to variations in the design and number of teeth in the gearing, but a much more complicated mechanism would be required in the Meccano model in order to increase still further the difference in speed between the shafts 4 and 9.

The steering gear illustrated will be found to work very well in Meccano models, for its reversibility is neither too great nor too small, and a reasonable speed reduction is provided between the steering wheel and the road wheels.

### Further Details of the Model

The construction of the remainder of the Meccano model of Ackermann steering gear will no doubt be clear from the illustrations, but further particulars regarding the mounting of the front wheels, etc., may be useful. Fig. 4 is a detailed view of one of the stub axle units. The  $1" \times \frac{1}{2}"$  Reversed Angle Bracket 13 is bolted to the second hole of the fixed front axle 21 (see Fig. 2) and supports a  $\frac{1}{2}"$  Bolt 14, which is gripped by the upper set-screw of the Coupling 16. The lower pivot of the Coupling consists of a 1" Axle Rod 15, secured by means of the lower set-screw.

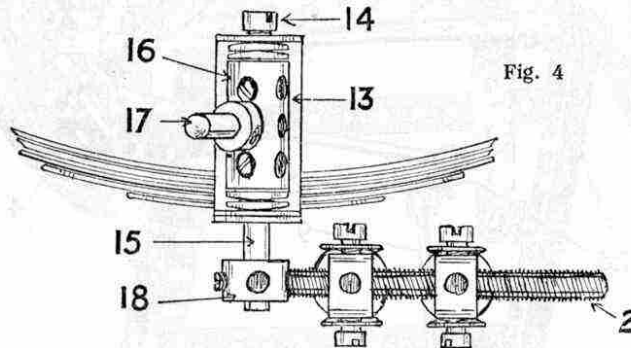

Fig. 4

(Part No. 140). This has been used in place of an ordinary Collar because a better grip on the Rod 15 can be obtained by inserting one, two, or even three set-screws in the threaded borings of the special collar in addition to the 2" Threaded Rod 2. The latter is of course screwed tightly into the collar. Two Washers are placed at top and bottom of the Coupling 16 to take up play in the bearings.

The several joints in the linkage consist of portions of Universal Joints, the various set-screws of which should be screwed up very tightly. The lever 1 consists of a  $\frac{3}{4}"$  Bolt, and the tie-rod 3 is composed of one  $3\frac{1}{2}"$  and one  $2\frac{1}{2}"$  Axle Rod joined together by the Coupling shown. The  $4\frac{1}{2}"$  Rod 22 carries a Collar 23 secured in place by an ordinary bolt, the shank of which, before entering the Collar, passes through the end hole in the Crank 12 and through the round hole of the Flat Bracket bolted thereon.

### Various Types of Steering Gear

There are several kinds of steering gears in common use in addition to the worm and bevel types already mentioned (the latter type being represented in Meccano by means of Pinion and Contrate Wheel gear, as in the well-known Meccano model Motor Chassis).

One form of steering mechanism sometimes met with makes use of plain rack-and-pinion gear, wherein a spur pinion engages with a rack that, in turn, is connected to the steering arm by means of a link-rod.

A crude form of steering apparatus used in the early days of motoring was operated by a wire cable attached to the front wheels and passed around a bobbin secured to the steering wheel shaft. On rotation of the steering wheel, the cable was wound on and off the bobbin, thereby imparting the turning movement to the road wheels.



The new Miniature Dunlop Tyre used in this model. See announcement on page 155

**Running a Miniature Railway—***(Continued from page 153)*

either on trestles or on some kind of brackets fixed to the wall. The foundation is usually wide enough to accommodate a double track and at one or more points it is widened to allow of the layout of stations and sidings. The large central table may be one constructed entirely of planks or may be an ordinary large table extended by planks on trestles as required.

**Introducing Realism**

A layout resting on a plain wooden foundation does not look very realistic and few real enthusiasts will rest content with this state of affairs. Fortunately it is comparatively easy to effect a remarkable improvement in realism by simple and inexpensive means. For instance, when the layout has been decided upon and the track is in position and fixed down either by hook nails or by screws through the sleepers, the whole may be ballasted, using some such material as very small granite chips or finely crushed coke, banked to the level of the sleepers. The portions of the wooden foundation that are not covered by the ballast may be camouflaged effectively by painting them over with very thin glue and sprinkling sand over the whole, subsequently dusting or brushing away any sand that the glue has not fixed in position. Some enthusiasts take matters a stage further by coating all the sleepers with black enamel.

It is not at all difficult also to provide a really picturesque background of suitable scenery. Very often by searching through a book of wallpaper patterns a suitable frieze with a country scene design may be selected that will meet all requirements. Alternatively, if the model railway engineer has any artistic ability or can secure the assistance of a friend who is clever in this direction, sufficiently realistic scenery may be painted on a background of some neutral tinted paper. It is surprising, until one tries it, how effective even the crudest work of this nature will appear.

In a future article we hope to return to this subject and to give detailed instructions for the preparation of scenic surroundings that will greatly enhance the appearance of any model railway.

In the case of a layout running around the room it is, of course, necessary to make provision for the opening of the door of the room, and generally this is most easily carried out by means of a lifting bridge. Later we shall deal with this matter also.

**Temporary Tracks**

The majority of boys, however, have to make the best of the table or floor in a living room, where the track has to be taken up after use and laid down afresh each time it is wanted. In most cases the floor will be employed, because the average table does not offer sufficient space for the development of an interesting layout, even with the small radius curves. The nature of the layout obviously must vary greatly with the size and shape of the room and the arrangement of the larger pieces of furniture, and for this reason it is very difficult to give advice that will be generally applicable. The possibilities of various layouts will be reviewed later, however, with the object of making clear the main principles that underly all effective and railway-like schemes.

All boys do not obtain their enjoyment from their miniature railways in the same manner. For instance, to some boys the

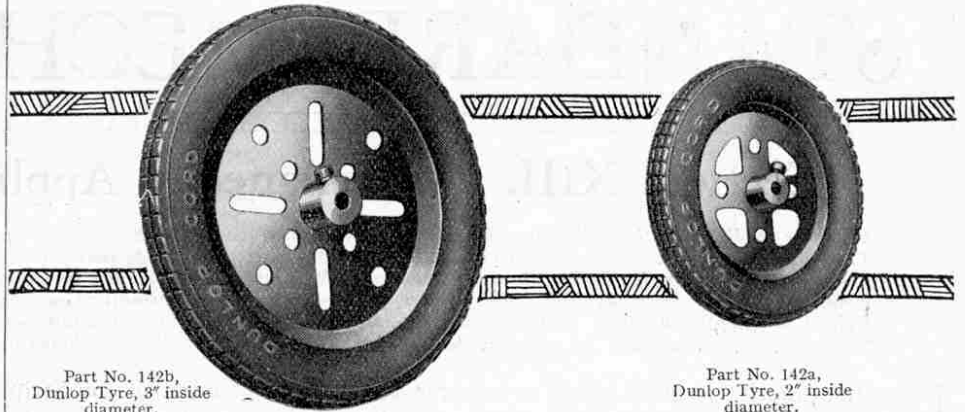
**Dunlop Tyres for Meccano Models****Add the Finishing Touch to Miniature Motors**

Part No. 142b,  
Dunlop Tyre, 3" inside  
diameter.

Part No. 142a,  
Dunlop Tyre, 2" inside  
diameter.

We feel sure that a great number of our readers will welcome with enthusiasm the news that scale model motor tyres are now included in the Meccano system. We have experienced a demand for these accessories for some time past and in order to fulfil the requirements of hundreds of Meccano boys we arranged with the Dunlop Rubber Co., Ltd., to manufacture and supply exact replicas in miniature of the famous Dunlop Cord Tyres.

In consequence of these arrangements we are now able to place the tyres upon the market in two different sizes, as shown in the accompanying illustrations.

The larger tyre has an internal diameter of 3" and a maximum diameter (from tread to tread) of 4". It is shown fitted to the Meccano 3" Pulley Wheel. The smaller size is of 2" inside diameter, or about 2 $\frac{3}{8}$ " over all, and is designed for use with the 2" Pulley Wheel.

The tyres are beautifully made and the well-known "non-skid" tread stands out in bold relief. It is scarcely necessary for us to add that they form excellent accessories for the Meccano Motor Chassis. Indeed, it is difficult to imagine a more pleasing model than that presented by the chassis fitted with scale model tyres, in addition to its existing realistic mechanical details. Meccano boys will do well to follow their fathers' examples and "Fit British tyres (to their models) and be satisfied!"

The prices of the Meccano tyres are as follows:—

Part No. 142a, Dunlop Tyre, 2" inside diameter, to fit Meccano Pulley Wheels	...	4d. each
Part No. 142b, Dunlop Tyre, 3" inside diameter,	do.	6d. each

engine is the main consideration, and they revel in pitting one engine against another and testing them in regard to speed, hauling power and length of run. Other boys merely regard their engines as part of the whole system and obtain their greatest pleasure by running trains, passenger and goods, express and slow, to a definite time-table. Time-table working with miniature railways is quite an art in itself and later we hope to show how fascinating it can be made. In addition there are boys who revel especially in the laying out and operation of complicated systems of sidings, and who will spend hours on end in working out shunting operations. In future instalments of this series we intend to deal with all these points of view and to show how the best fun may be obtained in each case.

**Care of the Track**

In the meantime it should be emphasised that continual laying down and taking up of the track imposes a severe strain upon it, and although the Hornby track is very strongly constructed, a reasonable amount of care in its use is necessary. In particular, care should be taken to avoid damage to points and crossings because if these, owing to rough handling, become bent out of shape, smooth running is impossible and derailments may result.

Next month we shall show how the best results are to be obtained from clockwork engines.

**Britain's Most Powerful Loco—***(Continued from page 99)*

only once dropped below 60 m.p.h.

The details of this run are recorded in the table shown on page 99.

**Extraordinary Public Interest**

The public interest in this great locomotive has been intense and at Waterloo it has been literally besieged by railway enthusiasts. Additional interest also is lent by the fact that the "Lord Nelson" is one of the few locomotives to have been driven by Royalty. The Duke and Duchess of York recently paid a visit to Ashford to fulfil certain engagements, including an inspection of the Southern Railway's works. After visiting the various erection shops, the Duke and Duchess concluded their tour by mounting the footplate of the "Lord Nelson," the Duke taking charge of the regulator and driving the engine from the works into Ashford station.

Other engines of the "Nelson" Class are to be built and will be named after the following famous sailors:—Lord St. Vincent, Lord Howe, Lord Rodney, Lord Hood, Lord Hawke, Howard of Effingham, Sir Francis Drake, Sir Walter Raleigh, Sir Richard Grenville and Martin Frobisher.

It is not intended to supersede the "King Arthur" Class and in fact further engines of this well-known type are to be constructed in the near future.