

Suggestions Page

(231)—A Meccano Front Wheel Drive

(R. Blake, Twickenham, Middlesex).

The great majority of cars on the road to-day are propelled by means of the rear wheels. This arrangement, although so popular, suffers from several disadvantages, the most serious of which is the liability to skid. When the direction of the motion of a car is changed in turning a corner, the tendency is for it to continue travelling in the original direction—in other words to skid, and this is intensified considerably by the effect of the rear wheel drive. If the engine drives the front wheels, however, it will be seen that a car will be drawn or pulled round a corner instead of being pushed, as is the case with the more usual form of transmission, so that the danger of a front wheel skid is greatly reduced. Many other advantages are claimed for this unique form of transmission, such as a low slung body, made possible by the elimination of the cardan shaft and the ordinary type of back axle, and the greater steering "lock" that may be placed on the front wheels. All these effects combine to make a car that is extremely safe to handle on bad road surfaces and under adverse weather conditions.

Meccano is an excellent medium for demonstrating mechanisms of all kinds, so that it is not surprising to learn that many readers have turned their attention to the designing of front-wheel drives, with the result that we have received many suggestions of this nature. It would appear, judging from the suggestions received, that most boys have only a vague idea of the difficulties in designing such a mechanism, so that it may be useful to consider some of the more important points before passing on to the description of the model shown in Fig. 231.

One of the first problems to be considered is that of conveying the drive from the engine to the front wheels. Whatever form of drive is employed, it must be such that the front wheels may be freely turned for steering purposes, and also may rise and fall easily under the action of the springs. A well-known make of British front wheel drive car employs universally jointed drive rods to attain this end, which is quite satisfactory in actual practice; but we are immediately confronted with an acute problem when an attempt is made to apply such a method to Meccano practice.

A Meccano Universal Coupling cannot be used to articulate the drive rod on account of its length. The reason for this statement will be readily seen when it is remembered that the centre of the Universal Coupling must coincide with the point about which swivels the stub unit. This is done in order to prevent the end of the drive rod describing an arc when the front wheels are put over to "full lock." By making the centre of the stub pivot and the Universal Coupling coincident, the road wheel is placed at a considerable distance from the pivot. This is a very undesirable state of affairs, as actually the wheel should be as close as possible to the pivot in order to make steering easy and to reduce the bending stresses on the stub axle unit.

This is a point that almost every contributor misses, and it will be observed that even in the model about to be described the position is far from ideal. It may be mentioned here that particulars of a new Meccano front wheel drive will shortly be published in the "M.M." In this model particular attention has been paid to the points just referred to, and by the employment of an entirely novel form of universal coupling the wheel track has been made practically coincident with the centre line of the pivot pins.

The front axle of the model shown in Fig. 231 consists of two pairs of $5\frac{1}{2}$ " Strips spaced apart by three Washers on the shanks of the bolts connecting them together. Each stub axle on which the road wheel is mounted, and is free to revolve, is secured in the plain

transverse bore of a Coupling. A 1" Rod is secured in each end of the Coupling. A $\frac{3}{4}$ " Pinion 4 is mounted boss downward on the upper 1" Rod, and the lower Rod is journalled in the end holes of the front axle.

The $\frac{3}{4}$ " Pinion is in constant mesh with a $1\frac{1}{2}$ " Contrate 7 that is secured to the road wheels by bolts. A $\frac{3}{4}$ " Contrate Wheel, also in mesh with the Pinion, is secured on the end of

each of the Rods leading from the differential. The outer ends of these Rods are journalled in $1" \times \frac{1}{2}"$ Angle Brackets; and the inner ends are journalled in the longitudinal bore of a Coupling, a $\frac{3}{4}"$ Contrate 2, 3, being secured to each Rod. The Coupling has secured in its centre transverse bore a $1\frac{1}{2}"$ Rod on which run $\frac{3}{4}"$ Pinions in constant mesh with the $\frac{3}{4}"$ Contrate Wheels 2 and 3. A $1\frac{1}{2}"$ Contrate Wheel is mounted freely on the Rod carrying the Contrate 2, and is driven by means of a $\frac{1}{2}"$ Pinion secured on the Rod 1.

A Bush Wheel is mounted loosely on the opposite Rod against the Boss of the Contrate 3, and is connected by 2" Screwed Rods to the $1\frac{1}{2}"$ Contrate, so that the two parts turn as one unit. Two $1" \times \frac{1}{2}"$ Angle Brackets bolted to the Bush Wheel engage with the ends of the Rod carrying the $\frac{3}{4}"$ Pinions. The Rod 1 is connected to the gear box of the chassis, and in order to allow for the vertical movement of the complete unit, due to the springing, it will be found necessary to incorporate two Universal Couplings between the output shaft of the gear box and the end of the Rod 1. The latter may, of course, be made much shorter than that shown in the illustration, but it is rather a disadvantage that the space taken up by the gear box and front axle unit is so great, as it makes the bonnet of the car unduly long.

A 1" Screwed Rod is inserted in the tapped hole of a Collar on the lower extremity of the 1" Rod forming each stub axle pivot, and is provided with a Swivel Bearing that serves as a means of connecting it to the track Rod 6.

The drag link from the steering arm is connected to a 1" Screwed Rod 5, which is screwed into a Collar fixed to the Coupling by a bolt that is inserted in its tapped hole.

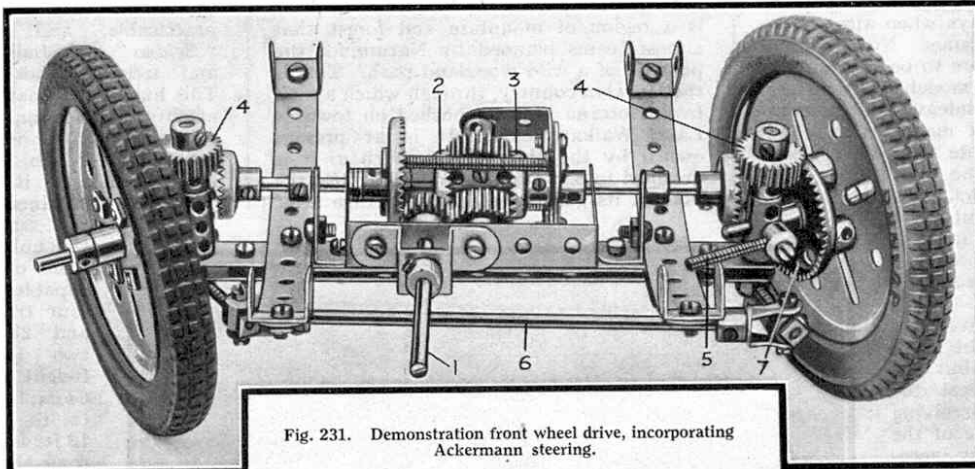

Fig. 231. Demonstration front wheel drive, incorporating Ackermann steering.

Suggestions Section

By "Spanner"

(491) A Model Egg Whisk

(B. T. Gillyatt, Chesterfield)

The model egg whisk shown in Fig. 491 is designed so that it may be clamped on the rim of a basin. The framework consists of a Face Plate 1 and a Bush Wheel 2, spaced apart by four $2\frac{1}{2} \times \frac{1}{2}$ " Double Angle Strips bent as shown. Four $3\frac{1}{2}$ " Strips are

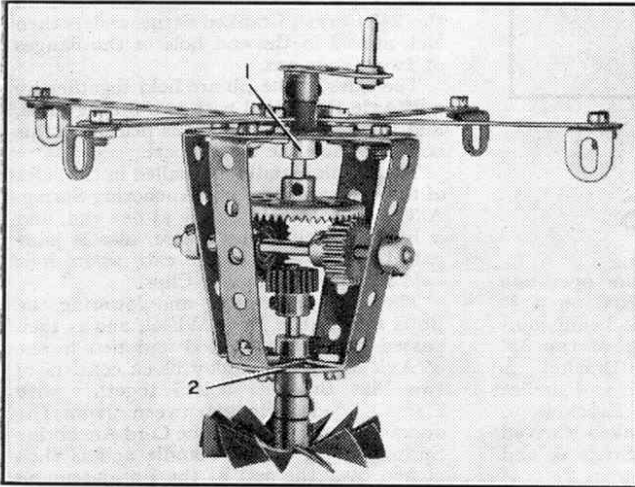

Fig. 491.

lock-nutted to the inner holes of the Face Plate, but they are spaced from it by a Washer and a Nut. The other ends of the Strips are bolted to $\frac{1}{2} \times \frac{1}{2}$ " Angle Brackets.

The handle is constructed by inserting a $1\frac{1}{2}$ " Rod firmly in the boss of a Crank, to which is secured a Threaded Pin. The $1\frac{1}{2}$ " Rod is journalled in the boss of the Face Plate and carries a $1\frac{1}{2}$ " Contrate Wheel on its other end. This Contrate meshes with a $\frac{3}{4}$ " Pinion on a 3" Rod that also carries a $\frac{3}{4}$ " Contrate Wheel. The $\frac{3}{4}$ " Contrate meshes with a $\frac{1}{2}$ " Pinion on a 2" Rod journalled in the boss of the Bush Wheel, and a Fan is secured to the other end of this Rod.

(492) Front Wheel Drive

("Spanner")

A front wheel drive arrangement similar to that incorporated in many sports cars is shown in Fig. 492. It can be fitted to almost any Meccano chassis of suitable size.

The front wheel is carried on a 1" Rod journalled in the boss of a Double Arm

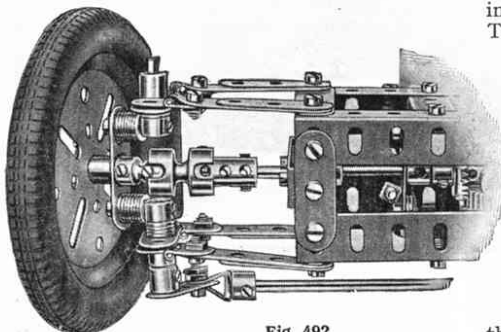

Fig. 492.

Crank. The inner end of this Rod supports a Handrail Coupling, the rounded portion of which fits into one end of a Socket Coupling. Although the Handrail Coupling is free to move universally, it is prevented from rotating from the Socket Coupling by means of a $\frac{7}{32}$ "

Grub Screw. This Grub Screw is locked in place by means of a $\frac{5}{32}$ " Grub Screw screwed into the opposite hole of the Handrail Support, and the portion of the long Grub Screw that projects engages with the slot in the Socket Coupling.

The opposite end of the Socket Coupling carries a Coupling by means of which the drive from the differential is transmitted through a Rod of suitable length to this part of the movement. The Rod is journalled in

$1\frac{1}{2} \times \frac{1}{2}$ " Double Angle Strips bolted to the front axle.

(493) Reversing and Drive-Changing Gear

("Spanner")

The mechanism shown in Fig. 493 allows two or three different operations to be controlled from a single driving shaft separately or simultaneously, and in the forward or reverse direction.

The Rod 1, which takes the drive from the Motor, carries a $\frac{3}{4}$ " Pinion 2 secured in the position shown. A similar Pinion 3 is free to rotate on the Rod, but is retained in position by a Collar and Set Screw 4. The Pinions engage with opposite sides of a $\frac{3}{4}$ " Contrate Wheel 5, which is free to turn on a short Rod fixed in the boss of a Bush Wheel 6. This wheel is bolted rigidly to the $2\frac{1}{2} \times \frac{1}{2}$ " Double Angle Strip that connects the side Plates of the gear box.

The secondary Rods 7 and 8 are slideable in their bearings and their movements may be controlled by levers 9. Each Rod carries a 50-teeth Gear Wheel 10, and on operation of its respective lever this Gear may be made to engage with one or other of the Pinions 2 or 3 or it may be placed

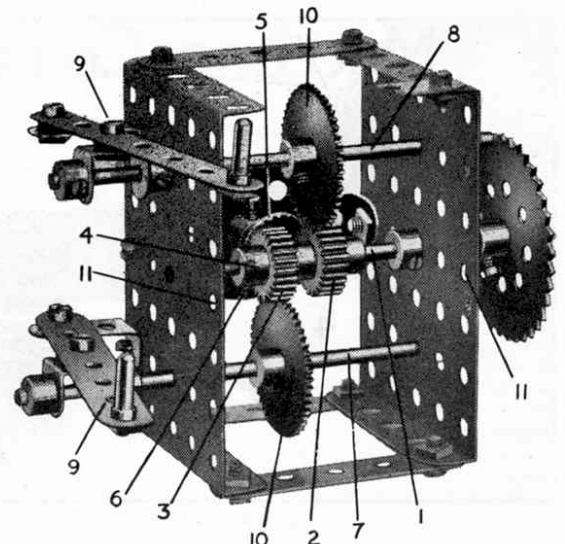

Fig. 493.

in neutral, that is, in a central position.

A third shaft can be journalled in the holes 11 of the side Plates and controlled from the driving shaft 1 in exactly the same way. The gear-box, therefore, enables the shafts 7 and 8 and the shaft journalled in the holes 11 to be driven simultaneously or separately from the single driving Rod 1.

(494) Electro-Magnetic Ratchet Feed

(J. Blacklin, Liverpool)

Electro-magnetic ratchet feed mechanisms fulfil an important part in the working of automatic traffic lights, and are also used extensively in automatic telephones for operating rotary switching

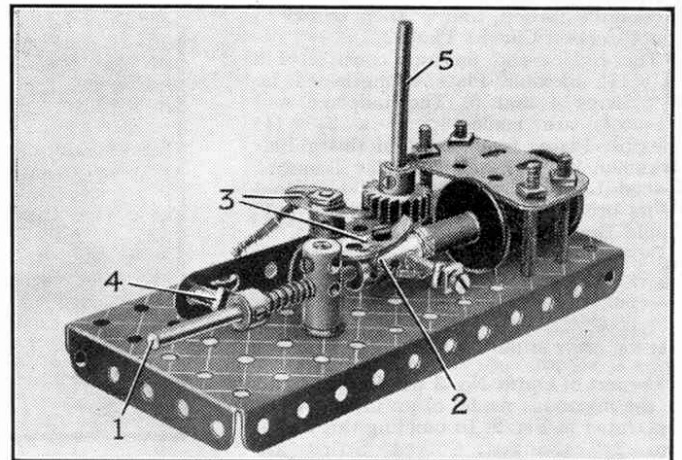

Fig. 494.

devices. Fig. 494 shows an electro-magnetic ratchet feed built in Meccano.

The base of the mechanism is a Flanged Plate, to one end of which an Elektron Solenoid is clamped by Flat Girders and $1\frac{1}{2}$ " Screwed Rods. A 3" Axle Rod 1 is connected to the Solenoid core by a Coupling 2, the other end of the Rod being journalled in a Threaded Coupling. A Compression Spring is placed on the Rod and is locked in position by a Collar, on one side of which is screwed a Threaded Pin 4 that slides in the slot of a 2" Slotted Strip mounted on the base. One of the Pawls is mounted on a 1" Threaded Rod, and the other on the Coupling 2.

Among the Model-Builders

By "Spanner"

FRONT-WHEEL DRIVE MECHANISM

This month I am describing a neat but strongly built front-wheel drive axle, and the slight extra trouble involved in fitting this to a vehicle will be repayed by the added interest it gives to a model. The mechanism is shown in Figs. 1 and 2.

The differential mechanism should be built up first. The crown wheel is represented by a $1\frac{1}{2}$ " Contrate 1, and it is fitted with two 1" Screwed Rods held in diametrically opposite holes by two nuts. A Collar is screwed on to the outer end of each of these Rods, and a $1\frac{1}{2}$ " Rod is fixed in the Collars. One of the Collars can be seen at 2. A Coupling 3 is held through its centre transverse hole on the $1\frac{1}{2}$ " Rod between

HOW TO USE MECCANO PARTS

STRIPS— DOUBLE ANGLE STRIPS

This is the first of the special notes dealing with Meccano parts and their uses that, as mentioned in the March "M.M.," are to appear in these pages during



R. Reynolds, Birkenhead, who won Second prize in the recent No. 4 Outfit Model-Building Competition.

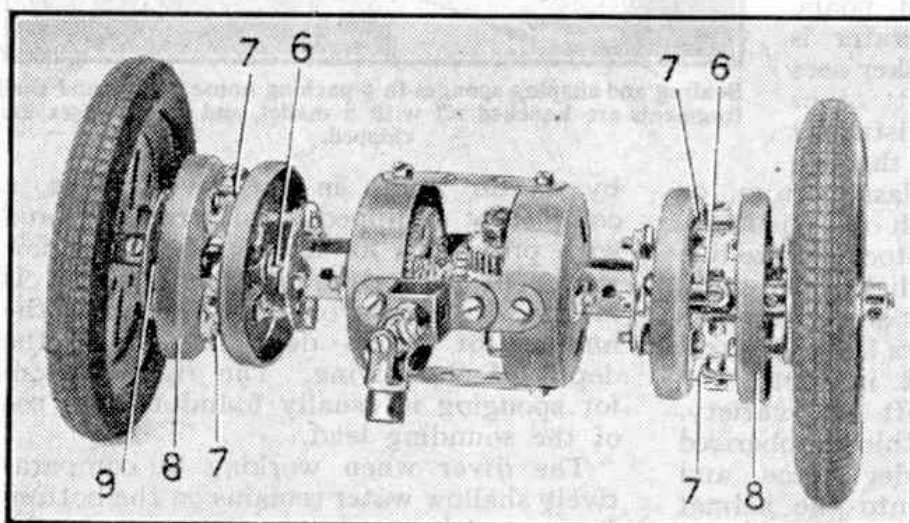

Fig. 1. Front-wheel drive mechanism for a model vehicle.

the Collars 2. A $\frac{1}{2}$ " Pinion is free to turn on a Pivot Bolt screwed into each side of the Coupling 3. A $\frac{1}{2}$ " Contrate 4 is fixed on a $2\frac{1}{2}$ " Rod passed through the Contrate 1 and into the Coupling 3. A second $\frac{1}{2}$ " Contrate is fixed on a 2" Rod passed into the opposite end of the Coupling 3. The differential is housed in a casing consisting of two Boiler ends connected by 2" Strips. The drive from the engine is taken through a Universal Coupling to a $\frac{1}{2}$ " Pinion 5 meshing with the Contrate 1.

The outer ends of the 2" and $2\frac{1}{2}$ " Rods carrying the $\frac{1}{2}$ " Contrates are supported in Wheel Discs attached to the Boiler Ends by Double Brackets, and they are each fitted with a Universal Coupling 6. A Wheel Flange is attached by $\frac{1}{2}$ " Bolts to each Wheel Disc, and is fitted with two Angle Brackets 7. A second Wheel Flange 8 is also fitted with two Angle Brackets, and these are connected by lock-nutted Bolts to the Angle Brackets 7. A Bush Wheel 9 is attached by $\frac{1}{2}$ " Bolts to each of the Wheel Flanges 8, and a $1\frac{1}{2}$ " Rod is free to turn in the boss of each Bush Wheel. These Rods carry the road wheels, and they are fixed in the Universal Couplings 6.

It is important to make sure that the spiders of the Universal Couplings are exactly in line with the lock-nutted Bolts in the Angle Brackets 7.

is well illustrated in Fig. 3, where a vertical column formed from four Angle Girders and eight short Strips is made absolutely rigid by the use of twelve $5\frac{1}{2}$ " Strips arranged in the form of simple bracing. This bracing can be laid out in many different ways, and some kind of bracing is required in all such models as bridges, cranes, buildings, and any other

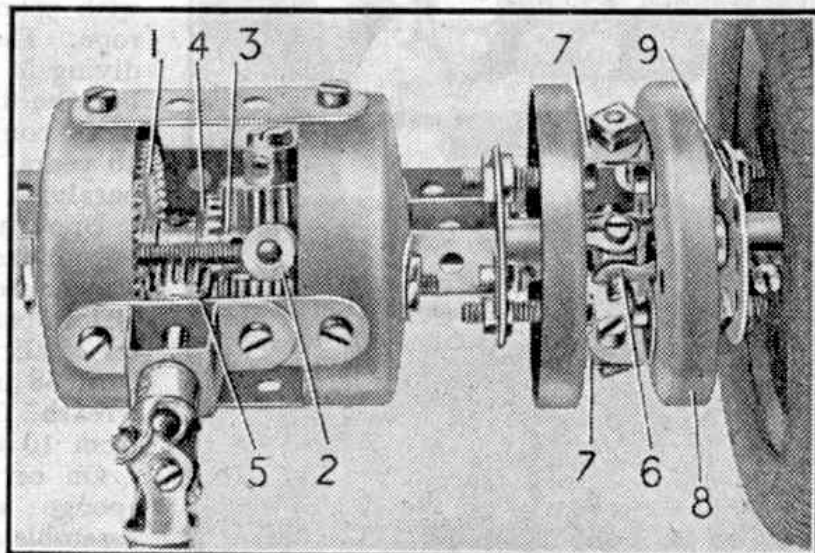

Fig. 2. A close-up showing one wheel arrangement of the front-wheel driving mechanism.

the coming months. The series will form a useful guide for model-builders. As Strips form the basis of nearly all models I am dealing with them first, and succeeding notes will describe usual and unusual applications for many of the other parts in the Meccano system.

There are two main uses for Strips, for bracing and for filling in, although the latter function is sometimes better fulfilled by other parts such as Flexible Plates. When used for bracing purposes, a few Strips, provided they are arranged correctly, will convert a flimsy weak structure into a rigid and strong structure. This point

Among the Model-Builders

By "Spanner"

FRONT-WHEEL DRIVE MECHANISM

This month I am describing a neat but strongly built front-wheel drive axle, and the slight extra trouble involved in fitting this to a vehicle will be repayed by the added interest it gives to a model. The mechanism is shown in Figs. 1 and 2.

The differential mechanism should be built up first. The crown wheel is represented by a $1\frac{1}{2}$ " Contrate 1, and it is fitted with two 1" Screwed Rods held in diametrically opposite holes by two nuts. A Collar is screwed on to the outer end of each of these Rods, and a $1\frac{1}{2}$ " Rod is fixed in the Collars. One of the Collars can be seen at 2. A Coupling 3 is held through its centre transverse hole on the $1\frac{1}{2}$ " Rod between

HOW TO USE MECCANO PARTS

STRIPS— DOUBLE ANGLE STRIPS

This is the first of the special notes dealing with Meccano parts and their uses that, as mentioned in the March "M.M.," are to appear in these pages during



R. Reynolds, Birkenhead, who won Second prize in the recent No. 4 Outfit Model-Building Competition.

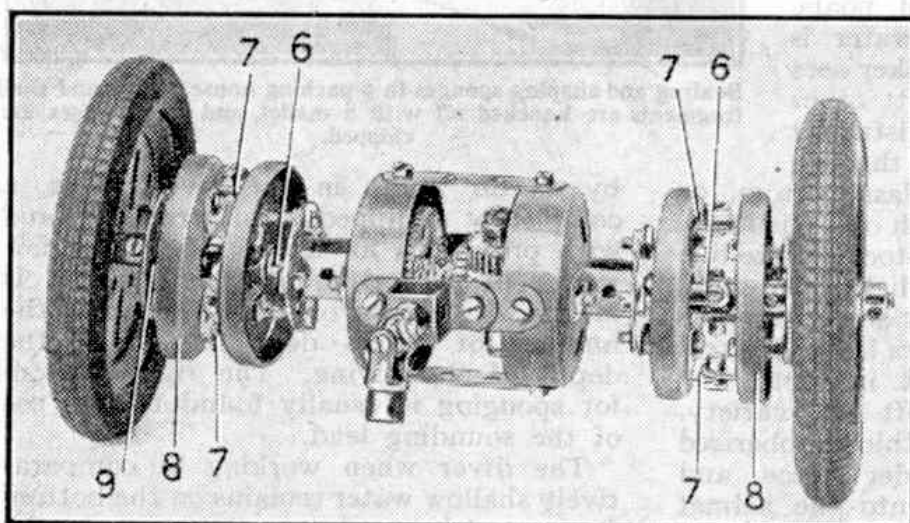

Fig. 1. Front-wheel drive mechanism for a model vehicle.

the Collars 2. A $\frac{1}{2}$ " Pinion is free to turn on a Pivot Bolt screwed into each side of the Coupling 3. A $\frac{1}{2}$ " Contrate 4 is fixed on a $2\frac{1}{2}$ " Rod passed through the Contrate 1 and into the Coupling 3. A second $\frac{1}{2}$ " Contrate is fixed on a 2" Rod passed into the opposite end of the Coupling 3. The differential is housed in a casing consisting of two Boiler ends connected by 2" Strips. The drive from the engine is taken through a Universal Coupling to a $\frac{1}{2}$ " Pinion 5 meshing with the Contrate 1.

The outer ends of the 2" and $2\frac{1}{2}$ " Rods carrying the $\frac{1}{2}$ " Contrates are supported in Wheel Discs attached to the Boiler Ends by Double Brackets, and they are each fitted with a Universal Coupling 6. A Wheel Flange is attached by $\frac{1}{2}$ " Bolts to each Wheel Disc, and is fitted with two Angle Brackets 7. A second Wheel Flange 8 is also fitted with two Angle Brackets, and these are connected by lock-nutted Bolts to the Angle Brackets 7. A Bush Wheel 9 is attached by $\frac{1}{2}$ " Bolts to each of the Wheel Flanges 8, and a $1\frac{1}{2}$ " Rod is free to turn in the boss of each Bush Wheel. These Rods carry the road wheels, and they are fixed in the Universal Couplings 6.

It is important to make sure that the spiders of the Universal Couplings are exactly in line with the lock-nutted Bolts in the Angle Brackets 7.

is well illustrated in Fig. 3, where a vertical column formed from four Angle Girders and eight short Strips is made absolutely rigid by the use of twelve $5\frac{1}{2}$ " Strips arranged in the form of simple bracing. This bracing can be laid out in many different ways, and some kind of bracing is required in all such models as bridges, cranes, buildings, and any other

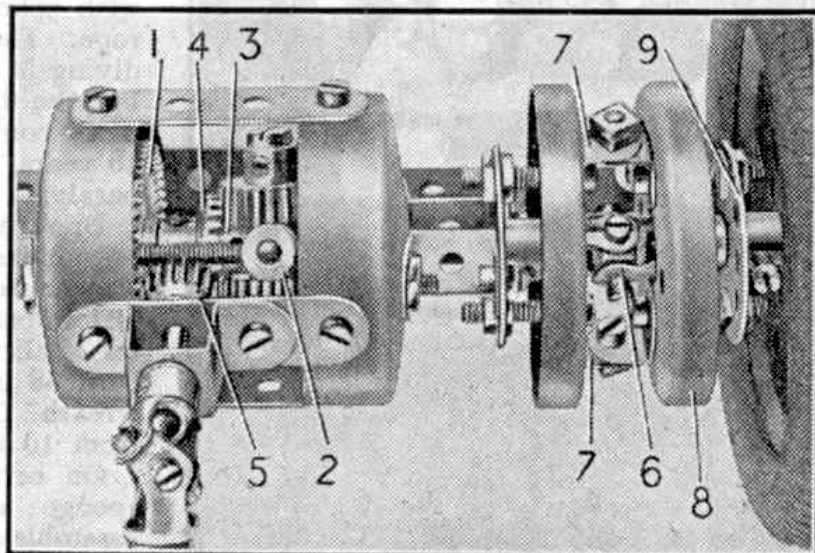

Fig. 2. A close-up showing one wheel arrangement of the front-wheel driving mechanism.

the coming months. The series will form a useful guide for model-builders. As Strips form the basis of nearly all models I am dealing with them first, and succeeding notes will describe usual and unusual applications for many of the other parts in the Meccano system.

There are two main uses for Strips, for bracing and for filling in, although the latter function is sometimes better fulfilled by other parts such as Flexible Plates. When used for bracing purposes, a few Strips, provided they are arranged correctly, will convert a flimsy weak structure into a rigid and strong structure. This point

Among the Model-Builders

By "Spanner"

An Unusual Quick Return Mechanism

Machine tools of all kinds make attractive subjects for model-builders with good stocks of parts at their disposal, as most of them incorporate interesting mechanisms. Among these are devices for speeding up the return or non-cutting stroke. Several quick return arrangements have been described in the *M.M.*, but the mechanism I am describing this month is specially interesting as it is operated by a Crank and an ingenious arrangement of pivoted levers that can be seen in the illustration below.

The Crank 1 is fixed on the driving shaft, and to it is pivoted on a lock-nutted bolt a $3\frac{1}{2}$ " Strip 2. The other end of this Strip is lock-nutted to a $2\frac{1}{2}$ " Strip 3 and a 3" Strip 4. A $\frac{3}{8}$ " Bolt is passed through the Strip 3 and is gripped in the boss of a Slide Piece, which is slipped over a $5\frac{1}{2}$ " Strip supported by Angle Brackets. The Strip 4 is bolted to a Crank that pivots freely on a $\frac{1}{2}$ " Bolt 5.

Assuming that the Crank 1 is rotating anti-clockwise, when it is in the position shown in Fig. 1 the Slide Piece moves slowly to the left, to make the cutting stroke. As the Crank turns towards the Bolt 5 the Slide Piece returns more rapidly. The closer the end of Crank 1 is to the Bolt 5, the more rapid is the movement of the Slide Piece.

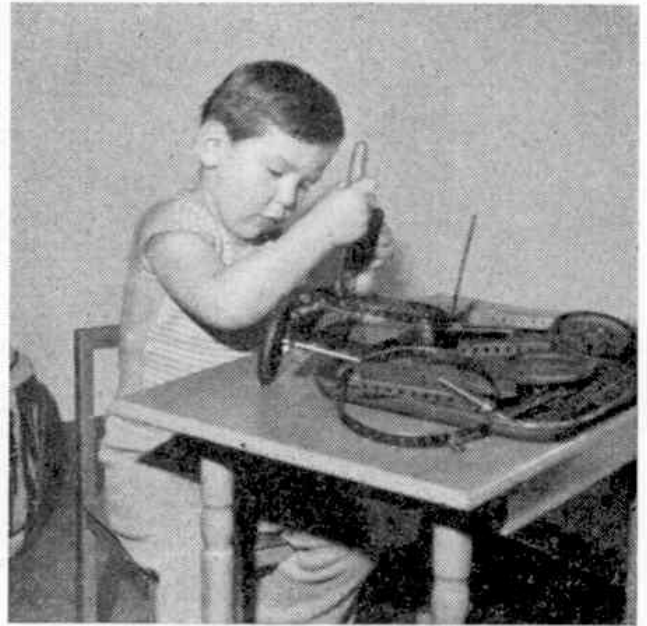

Is he the youngest reader of the "M.M."? Denis Philippe Donner, Bienne, Switzerland, is only four years of age, but he is already a Meccano enthusiast and takes a keen interest in the "M.M."

A Meccano Front-Wheel Drive Mechanism

The introduction of the Dinky Toys Army Covered Wagon has prompted many enthusiasts to make Meccano models of this and other army vehicles and several have written to tell me of the difficulties they have found in reproducing the front-wheel drive mechanisms fitted to most up-to-date army vehicles. Actually it is quite easy to assemble an efficient front-wheel drive mechanism from standard parts, and the arrangement shown in Fig. 2 is quite satisfactory.

The front axle consists of two built-up strips, each made from two $5\frac{1}{2}$ " Strips overlapped nine holes. The strips are spaced apart by three Washers on each of the Bolts that fixes them to the front springs. The road wheels are mounted quite freely on short Rods, each of which is fixed in a Coupling that carries two 1" Rods. A $\frac{3}{4}$ " Pinion 4 is free to turn on the upper 1" Rod, but it is held in place by a Collar, and the

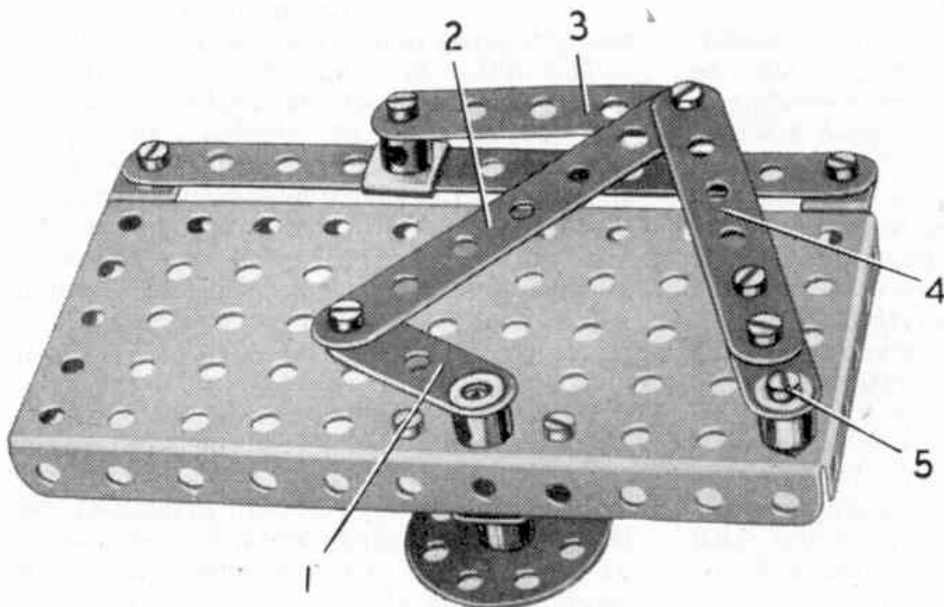

Fig. 1. A quick return mechanism of unusual design, suitable for use in planing machines and models of other machine tools.

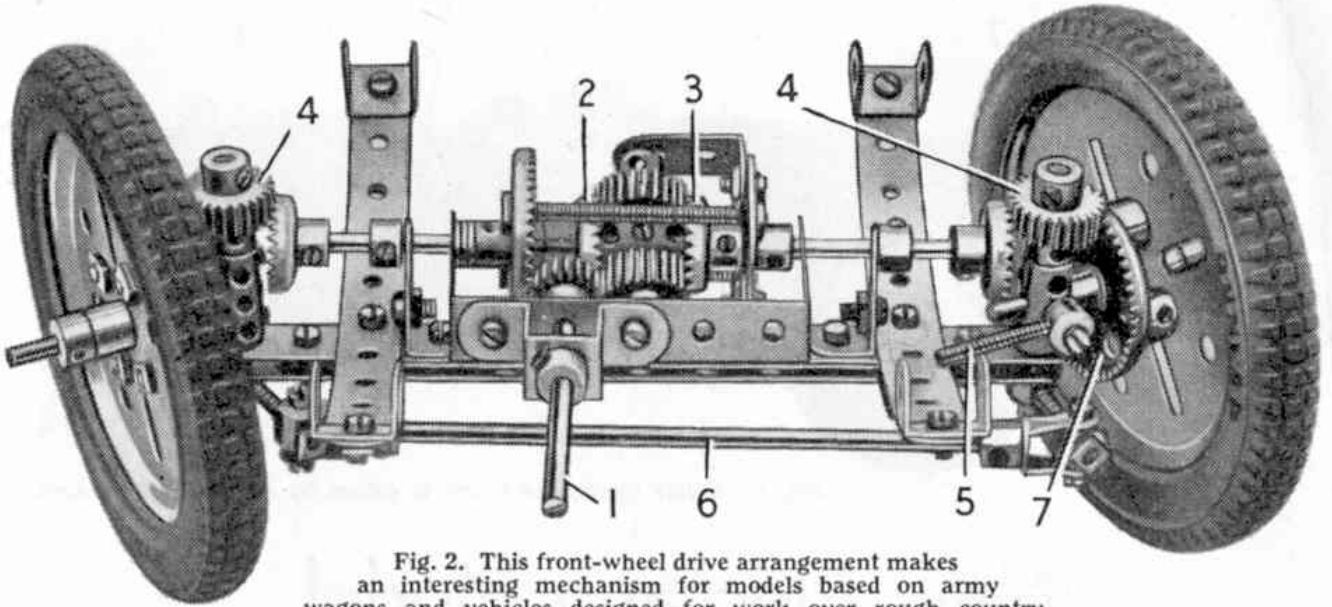

Fig. 2. This front-wheel drive arrangement makes an interesting mechanism for models based on army wagons and vehicles designed for work over rough country.

lower Rod is supported in the end holes of the front axle and is also kept in position by a Collar. A $1\frac{1}{2}$ " Contrate 7, spaced from each road wheel by Collars on $\frac{1}{2}$ " Bolts, is driven by the Pinion 4. A 1" Screwed Rod threaded into the Collar on each of the lower 1" Rods is provided with a Swivel Bearing. The Swivel Bearings are connected by a Rod 6. Another 1" Screwed Rod 5 is fixed in a Collar attached by a $\frac{3}{8}$ " Bolt to one of the Couplings. This Screwed Rod is connected by suitable links to the steering gear.

The driving shaft to the differential is a Rod 1 supported in a Double Bent Strip and a $2\frac{1}{2}$ " x 1" Double Angle Strip. A $\frac{1}{2}$ " Pinion on Rod 1 drives a $1\frac{1}{2}$ " Contrate that is connected to a Bush Wheel by 2" Screwed Rods. Two 1" x $\frac{1}{2}$ " Angle Brackets are bolted to the Bush Wheel, and in them is mounted a $1\frac{1}{2}$ " Rod fitted at its centre with a Coupling. Two $\frac{3}{4}$ " Pinions are free to turn on the $1\frac{1}{2}$ " Rod.

The differential half shafts are supported in 1" x $\frac{1}{2}$ " Angle Brackets bolted to the front axle, and are passed through the $1\frac{1}{2}$ " Contrate and the Bush Wheel into the centre Coupling of the differential. The $\frac{3}{4}$ " Contrates 2 and 3 on the half shafts are meshed with the $\frac{3}{4}$ " Pinions.

A $\frac{3}{4}$ " Contrate fixed to the outer end of each half shaft is arranged so that it drives one of the Pinions 4.

Non-Slip Built-Up Pulley

Master J. Basham, Romford, tells me that he has found the simple built-up pulley shown in Fig. 3 useful for operating the traversing Cord of simple hammerhead cranes as it prevents cord slip. The pulley is very simple and consists of two 1" fixed Pulleys fitted with Motor Tyres and pressed tightly one on each side of a 1" loose Pulley fitted with a Rubber Ring.

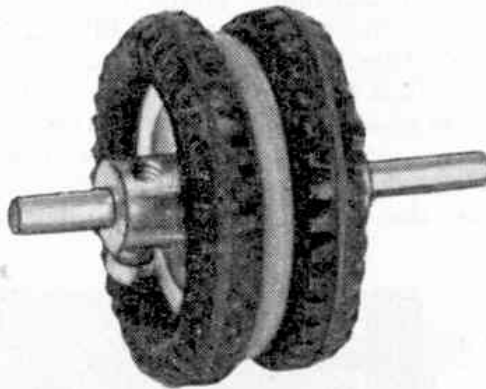

Fig. 3. Master J. Basham, Romford, is the designer of this non-slip pulley arrangement for operating the traversing Cords of model cranes.

"SIMPLICITY" MODEL-BUILDING CONTEST

Here is a contest in which owners of even the smallest Meccano Outfits can compete on level terms with those more fortunate possessors of the largest sets, and we hope that every Meccano boy who reads this announcement will decide to send in an entry. Prizes will be awarded to model-builders who succeed in constructing the most ingenious and realistic models from the *smallest number of parts*. A competitor may choose any subject he likes for his model, and the more unusual and

interesting this is the better the chance of winning a prize, provided that the model is kept quite simple.

When the model is completed the competitor should obtain either a photograph or a good drawing of it. He should then write his age, name and address on the back of the illustration and send it to "Simplicity Model-Building Contest, Meccano Ltd., Binns Road, Liverpool 13." The actual model must not be sent.

The competition will be divided into two Sections: A, for readers under 14 years of age, and B, for readers over 14 years of age. The closing date is July 31st next.

The Prizes to be awarded in each Section are as follows. First, Cheque for £3/3/-. Second, Cheque for £2/2/-. Third, Cheque for £1/1/-. There will be also Ten Prizes each of 10/- and Ten Prizes each of 5/-.

Among the Model-Builders

By "Spanner"

A Front Wheel Drive Mechanism

Fig. 1 on this page shows an efficient front wheel drive axle suitable for use in models such as four wheel drive Army vehicles. The axle is fitted with a differential mechanism, and the arrangement enables the wheels to be fully steerable when the vehicle is in motion.

The crown wheel of the differential fitted in this mechanism is a $1\frac{1}{2}$ " Contrate 1, which is mounted freely on the Rod forming one of the half-shafts. A $\frac{3}{4}$ " Contrate 2 is fixed on the same Rod and two 1" Screwed Rods are fixed by two nuts each in diametrically opposite holes in the Contrate 1. The inner end of the

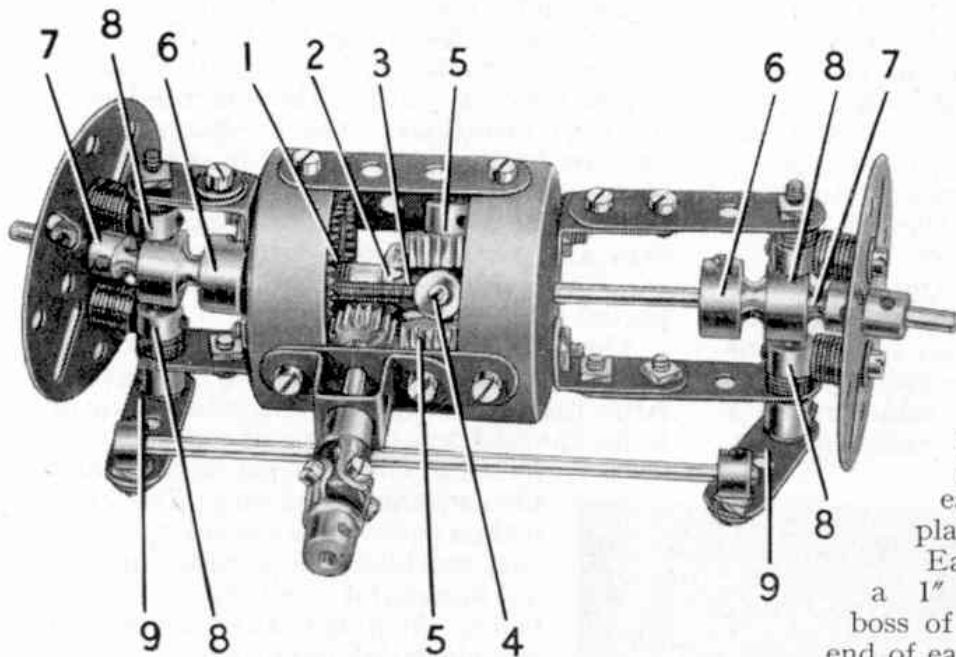

Fig. 1. The front wheel drive mechanism that is described in detail on this page.

half-shaft passes into one end of the bore of a Coupling 3, in the centre cross hole of which a $1\frac{1}{2}$ " Rod 4 is fixed. This Rod is gripped at each end in a Collar screwed on to the end of one of the Screwed Rods.

Two $\frac{3}{4}$ " Pinions 5 turn freely on Pivot Bolts screwed into the Coupling 3. The Pinions engage the Contrate 2 and another similar Contrate fixed on a Rod that forms the second half shaft.

The complete differential is mounted

in a casing made from two Boiler Ends connected by four 2" Strips. One of the Strips is spaced from the Boiler Ends by two Washers on each of the Bolts that hold it in place, and to this Strip is bolted a Double Bent Strip.

The driving gear is a $\frac{1}{2}$ " Pinion that engages the Contrate 1. The Pinion is fixed on a $1\frac{1}{2}$ " Rod mounted in the Double Bent Strip and the 2" Strip. Washers are placed on the Rods to ensure that the

Contrates and the Pinions mesh accurately.

The differential casing is extended on each side by two $1" \times \frac{1}{2}"$ Angle Brackets bolted to the Boiler Ends. Those on one side have their slotted holes covered by Fishplates, and to those on the other side two 2" Strips are bolted. A Collar is fixed to the outer end of each half shaft and on it is placed a Socket Coupling 6.

Each front wheel is fixed on a 1" Rod supported in the boss of a Face Plate. The inner end of each Rod carries a Handrail Coupling 7 that fits into the end of one of the Socket Couplings 6. Each Handrail Coupling is fitted with a $\frac{7}{32}"$ Grub Screw screwed into the threaded hole opposite to the standard Grub Screw provided in the rounded end. The two Grub Screws are tightened against each other so that they cannot come unscrewed, and the projecting head of the $\frac{7}{32}"$ Grub Screw engages the slot in the Socket Coupling. This arrangement permits the Handrail Couplings to pivot in the Socket Couplings as the front wheels are steered, although they rotate as a unit owing to



B. A. Crack, Bury St. Edmunds, one of the many model-builders who have been successful in "M. M." Model-Building Competitions.

the engagement of the Grub Screws in the slots.

Two $\frac{1}{2}$ " Bolts are passed through each Face Plate and each is fitted with Washers before it is screwed into a Collar 8. The upper Collar on each side is fixed on a Threaded Pin, and the lower Collar is held on a 1" Rod. Cranks 9 on the 1" Rods are connected by a Rod fixed in two Collars, each of which is screwed on to a bolt held by a nut in one of the Cranks.

A Made-up Bush Wheel

Some time ago I received a letter from P. M. Slotkin, High Wycombe, Bucks, who owns a No. 6 Outfit and is a very keen model-builder. During the course of his model-building activities he has found occasional need for an extra Bush Wheel

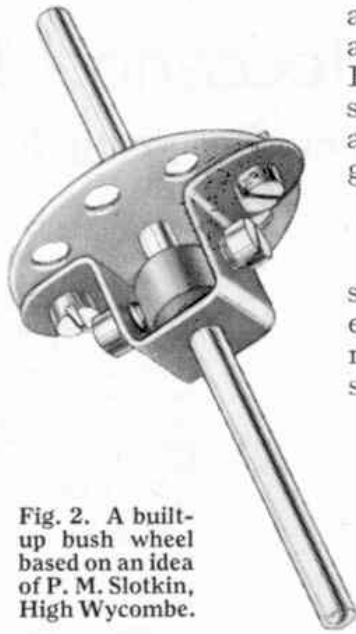

Fig. 2. A built-up bush wheel based on an idea of P. M. Slotkin, High Wycombe.

and carries a Collar between the arms of the Double Bent Strip. Bolts are then passed through the side holes of the Double Bent Strip and are screwed into the Collar to grip the Rod.

An Outstanding Model

Models of the less common subjects are always interesting, especially when they have such a realistic appearance and display such excellent workmanship as the model of a large planing machine built by our old friend B. W. Rowe, Newton Abbot, which is illustrated on this page. I do not remember ever having seen a better model of this type and readers may be interested to know that

it is based on a machine manufactured by John Stirk and Sons, Halifax, which was illustrated in the *M.M.* some years ago.

Operated by two Electric Motors, the model has all the essential movements, tool saddle and tool holder feeds of its prototype, and the reciprocating movement of the workbed is entirely automatic in action. Well-proportioned, neatly and

sturdily constructed, the model is altogether an outstanding example of Meccano construction, and well up to the standard I have come to expect from this very enthusiastic

Fig. 3. A splendid model planing machine constructed by B. W. Rowe, Newton Abbot, whose high standard of workmanship has already won him many prizes in Meccano Competitions.

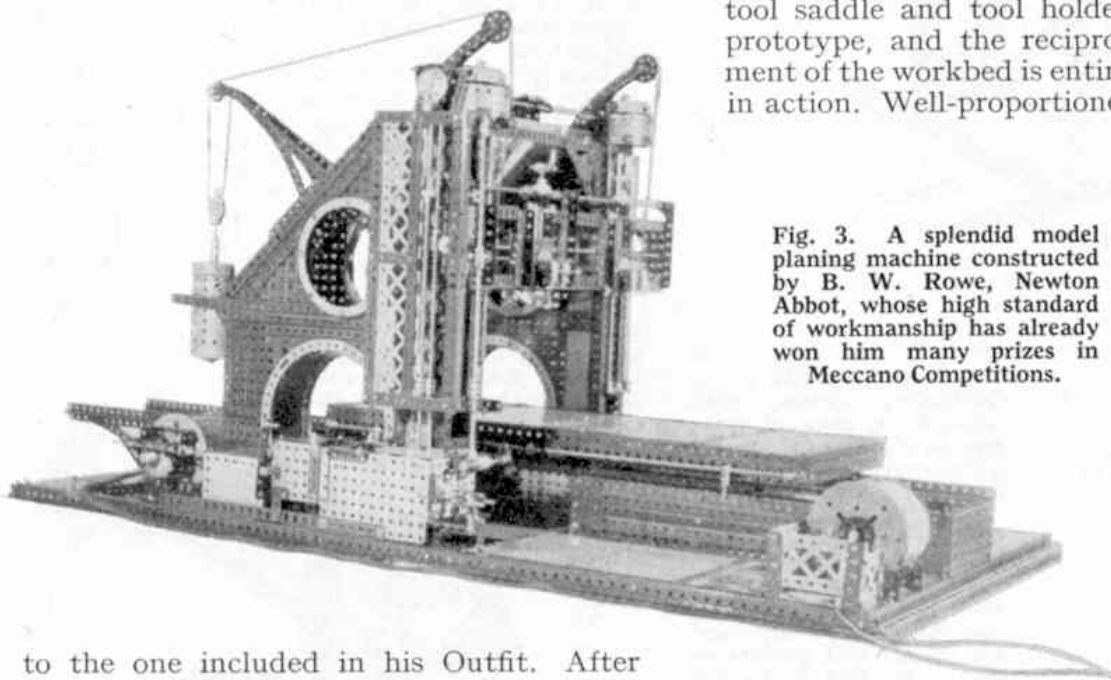

to the one included in his Outfit. After a little experimentation he devised the simple arrangement seen in Fig. 2, and he sent details of it to me in the belief that other model-builders might find the scheme useful in similar circumstances, when the lack of a proper Bush Wheel might hold up their activities.

The arrangement is quite simple and is made by bolting a Double Bent Strip to a Wheel Disc. Either the eight-hole Wheel Disc or the new Wheel Disc with six holes can be used for this purpose. A Rod is passed through the centre hole of the Wheel Disc and the Double Bent Strip,

and experienced model-builder.

The saddle is counterweighted by means of Boilers filled with odd parts and has helical gearing situated in the housings at the tops of the columns.

The twin tool saddles are independently controlled from the main distribution box, and the main horizontal saddle is raised and lowered by a screw mechanism consisting of $11\frac{1}{2}$ " Screwed Rods.

The machine will actually plane blocks of soft material such as wax and is nearly 4 ft. in length and over 2 ft. in height.

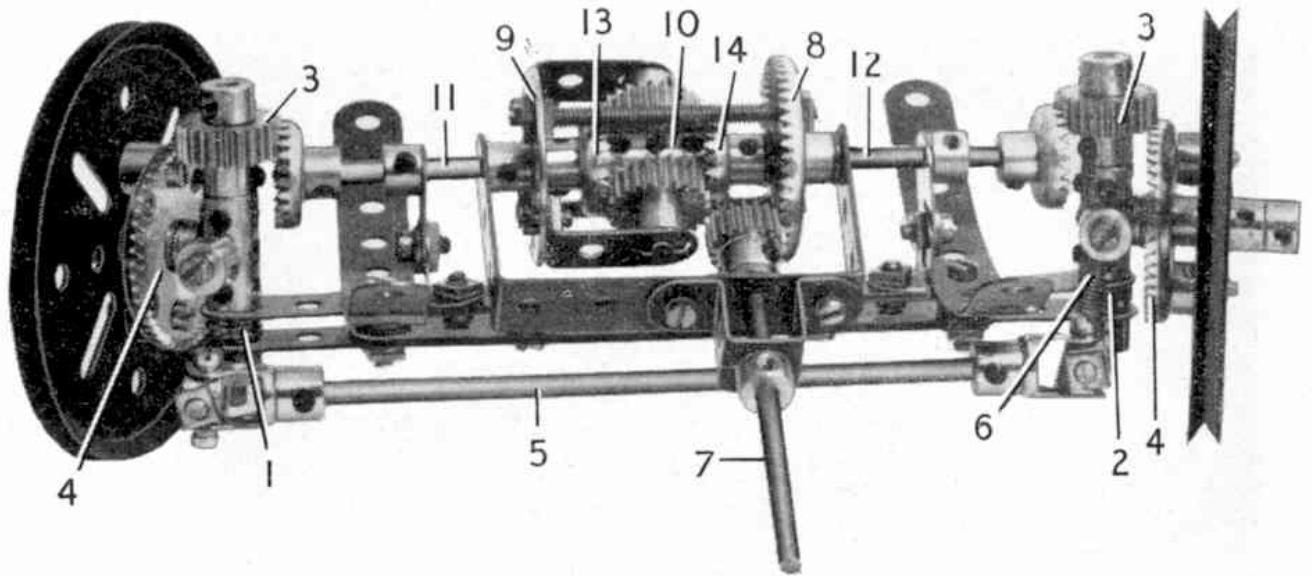

Fig. 1. A neat front wheel drive mechanism that can be built into suitable model motor vehicles.

Among the Model-Builders

By "Spanner"

Front Wheel Drive for Meccano Motor Cars

I receive so many enquiries for a front wheel drive mechanism for vehicles that I have decided to repeat here details of a scheme that was illustrated in the *Meccano Magazine* some time ago. A picture of this mechanism appears on this page, and it will be found quite easy to assemble and to build into models of suitable type and size.

The front axle consists of two built up strips, each of which is made up from two $5\frac{1}{2}$ " Strips overlapped nine holes. The Strips are spaced apart by three Washers 1 and 2 on each of the Bolts that fix them to the front springs. The road wheels are mounted freely on short Rods, each of which is fixed in a Coupling that carries two 1" Rods. A $\frac{3}{4}$ " Pinion 3 is free to turn on the upper 1" Rod but is held in place by a Collar, and the lower Rod is supported in the end holes of the front axle and is also kept in position by a Collar. A $1\frac{1}{2}$ " Contrate 4, spaced from each road wheel by Collars on $\frac{1}{2}$ " Bolts, is driven by the

Pinion 3. A 1" Screwed Rod threaded into the Collar on each of the lower 1" Rods is provided with a Swivel Bearing. The Swivel Bearings are connected by a Rod 5. Another 1" Screwed Rod 6 is fixed in a Collar attached by a $\frac{3}{8}$ " Bolt to one of the Couplings. This Screwed Rod is connected by suitable links to the steering gear.

The driving shaft to the differential is a Rod 7 supported in a Double Bent Strip and a $2\frac{1}{2} \times 1\frac{1}{2}$ " Double Angle Strip. A $\frac{1}{2}$ " Pinion on Rod 7 drives a $1\frac{1}{2}$ " Contrate 8 that is connected to a Bush Wheel 9 by 2" Screwed Rods. Two $1 \times \frac{1}{2}$ " Angle Brackets are bolted to the Bush Wheel and in them is mounted a $1\frac{1}{4}$ " Rod fitted

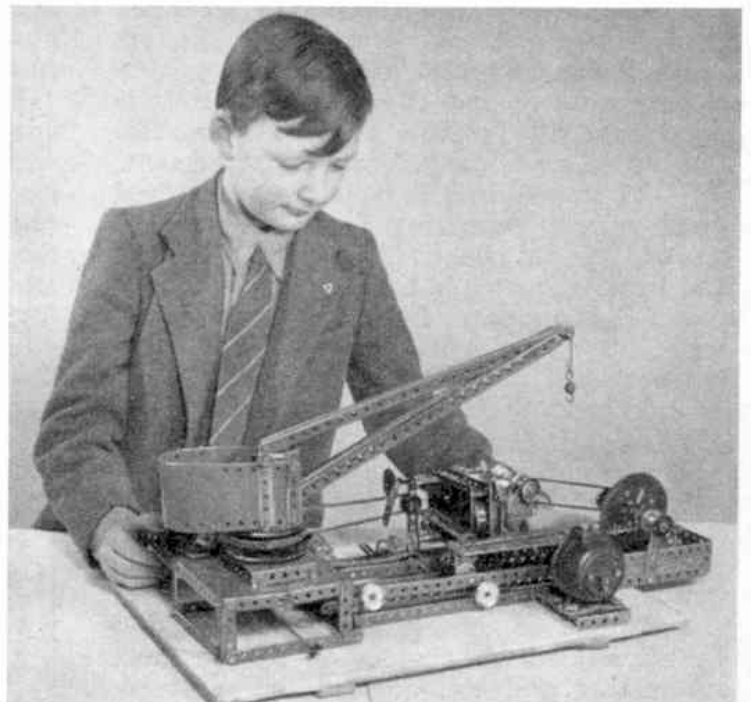

Peter Jones, Eccleshall, Staffs., and the ingenious automatic sawmill plant he designed and built.

at its centre with a Coupling 10. Two $\frac{3}{4}$ " Pinions are free to turn on the $1\frac{1}{2}$ " Rod.

The differential half shafts 11 and 12 are supported in Fishplates bolted to Angle Brackets, which in turn are bolted to the front axle, and are passed through the $1\frac{1}{2}$ " Contrate and the Bush Wheel into the centre Coupling 10

of the differential. The $\frac{3}{4}$ " Contrates 13 and 14 on the half shafts are meshed with the $\frac{3}{4}$ " Pinions.

A $\frac{3}{4}$ " Contrate fixed to the outer end of each half shaft is arranged so that it drives one of the Pinions 3, which in turn drives the Contrate Wheel 4.

A Model Automatic Sawmill

A few months ago I had the pleasure of meeting at Binns Road a young model-builder who had travelled from Staffordshire specially to show me a fine model automatic sawmill plant he had built. Peter Jones is his name and he lives on a farm at Eccleshall, Staffordshire. Peter is seen with his model in the lower illustration on the previous page, but the ingenuity he has shown in building it can only be appreciated when the model is actually seen in operation. The model has two power units—an Electric Motor and a Clockwork Motor. The sequence of operations is as follows. First the crane swivels round so as to be in a suitable position to pick up a piece of timber from a pile near

the side of the plant. By juggling with the appropriate levers Peter is able to make the crane pick up the timber, swivel round again, and deposit the timber on to the conveyor of the sawing unit at the right-

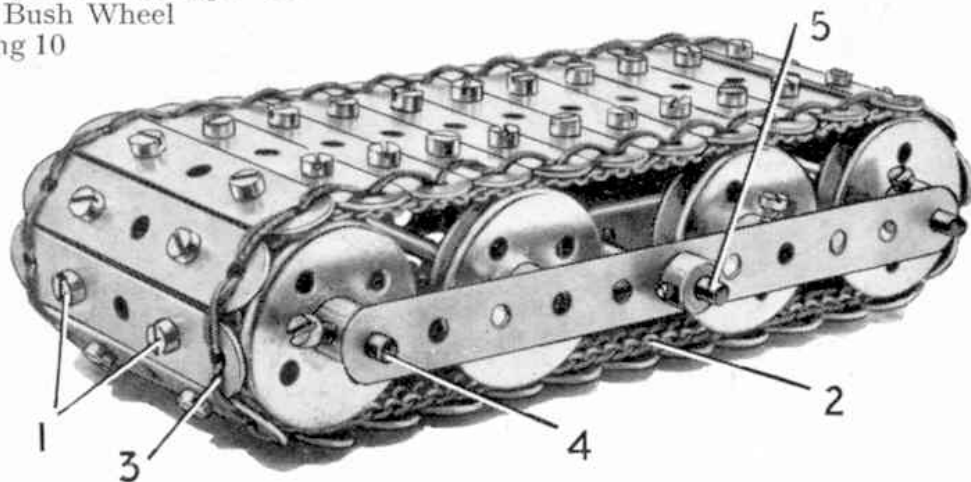

Fig. 2. Creeper track consisting of Strips linked by Cord to lengths of Sprocket Chain.

hand end of the plant. Further manipulation of the controls then sets the conveyor in motion and the timber is carried forward to the saw, which is driven by the Electric Motor. After sawing is completed the conveyor reverses.

Peter told me that in order to cope with a possible breakdown in the electric supply he has provided an emergency system under which the entire plant can be worked by the Clockwork Motor alone!

Congratulations, Peter, on your ingenuity in arranging the various mechanisms, and also on the original nature of your model.

Another Idea for Creeper Track

The making of creeper track for tracked vehicles is not easy, but for those who have plenty of Strips, Angle Brackets and similar constructional parts available there are many possibilities for experiment. One of these is shown in Fig. 3, which illustrates a method of track construction devised by Clive Greenall, Gisborne, New Zealand. In this example each section of the track consists of two $1\frac{1}{2}$ " Strips 1, two $2\frac{1}{2}$ " Strips 2, one Double Bracket 3, and one

(Continued on page 120)

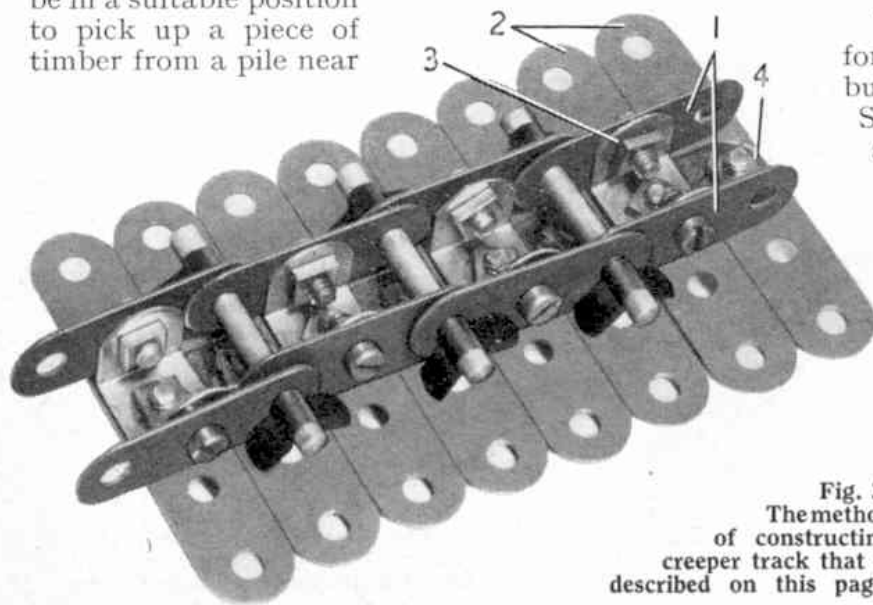
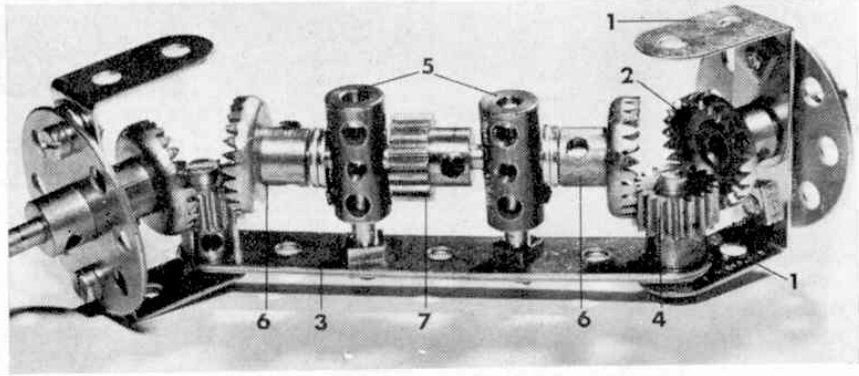

Fig. 3. The method of constructing creeper track that is described on this page.

Suggested by Mr. R. A. Dobson of Pudsey, Yorkshire, this interesting Front-Wheel Drive Unit is ideal for heavy-duty and commercial vehicles.



A gear-change lever is provided by a 4 in. Rod secured in one end of a Universal Coupling 25, pivotally connected to a 1½ in. Strip fixed to Plate 1 by a 1 × 1 in. Angle Bracket. The gear lever, carrying a Handrail Coupling 26 at its upper end, is located between the Bolts in the Collars on Rods 18 and 24.

Although equipped with gate-change, this gearbox is unlike the type found in real cars in that the movement of the gear level in the gate is different to that found in a car. In a typical car, movement of the gear lever usually follows an "H" pattern, the gears being changed by moving the gear lever direct from one position to the next. It is never necessary to move the lever from one position to the next and then to a third position just to change one gear, but it can be necessary in the Meccano gearbox. This is because there are two positions for each control shaft 18 and 24, therefore, to obtain four gears, both shafts must sometimes be moved. Nonetheless it is still an extremely useful gearbox. The following parts list, incidentally, applies to the mechanism exactly as illustrated.

PARTS REQUIRED:

1—2	1—15	1—27a	6—59
1—5	1—15a	30—37a	1—63d
4—6a	1—15b	33—37b	2—72
1—9e	2—16	12—38	2—111c
3—12	3—25	2—45	1—136a
1—12a	1—26	2—47a	1—140
2—12b	3—27	1—48a	1—230

Front-wheel drive

Staying with mechanisms, but moving away from gearboxes, we come to a Front-wheel Drive system suggested by Mr. R. A. Dobson of Pudsey, Yorkshire. Front-wheel drive, of course, has frequently proved invaluable, particularly when fitted to heavy-haulage tractors and "cross-country" vehicles such as Land-Rovers, etc. It does, however, result in the added difficulty of having to incorporate a variable direction drive—necessary because the front wheels of most vehicles provide the steering and are, therefore, constantly changing direction. This difficulty is especially present in Meccano models because of the understandable limitations of a miniature system compared to the real thing, but Mr. Dobson has overcome the problem extremely well. All the same, he does stress that his

PARTS REQUIRED: (For Unit as illustrated)

1—3	2—18b	4—29	8—38
4—12a	2—24	8—37a	2—63
1—17	3—26	4—37b	2—111
	2—115		

method, rather than being for general use, is more suited to "commercial and other heavy-duty vehicles, where haulage power is more important than speed."

Construction of the mechanism is fairly obvious from the accompanying illustration which, by the way, shows it in partly dismantled form. Each stub axle consists of two 1 × 1 in. Angle Brackets 1 bolted to an 8-hole Bush Wheel mounted, along with a ¾ in. Contrate Wheel 2, on a short Axle Rod. The road wheel would also be mounted on this Rod. Lock-nutted between the free lugs of each lower Angle Bracket are two 3½ in. Strips 3, one on top of the other, the securing ¾ in. Bolt in each case also holding a ½ in. Pinion 4.

Next, two Threaded Pins are fixed in Strips 3 and on them are mounted two Couplings 5. Journalled in the centre transverse smooth bores of these Couplings is a 2½ in. Rod carrying a ¾ in. Contrate Wheel 6 at each end and a ½ in. Pinion 7 in the centre. Contrates 6 engage with Pinions 4, while the drive from the Motor is taken to Pinion 7.

When fitted to a model, the free lugs of upper Angle Brackets 1 would be joined and the whole assembly would be fixed to the chassis in some way. A steering linkage would also be provided, probably by Strips bolted to one of the Angle Brackets and, finally, the drive would be taken to Pinion 7 either by a Worm or a Gear Wheel.



AIR NEWS continued from page 336

ment of eight machine-guns, represented the first of a whole new generation of modern, heavily-armed mono-plane fighters.

When Sir Robert Watson-Watt discovered the possibilities of radar, the R.A.F. was quick to put it to use and this, as much as anything, ensured victory in the Battle of Britain in 1940. When peace returned, the radar aids employed by Bomber Command to improve its navigation and bombing accuracy during the great night offensive against Germany, became available to make airline flying safer and more reliable than ever before.

It cannot be claimed that the Air Ministry showed much enthusiasm when one of its young officers, named Frank Whittle, said that he believed he could design and build a practical jet-engine in the 'thirties and asked for official support. But it was not alone in its scepticism, and when Whittle proved his claim the Air Ministry was so quick off the mark in ordering jet fighters that the Meteor became the first jet to be used in action, in July 1944.

As we know, the jet-engine went on to revolutionise airline flying. It will be surprising if, one day, the airlines do not benefit just as greatly from the vertical take-off capability that the R.A.F. is pioneering, with the Harrier, at the beginning of its second 50 years.

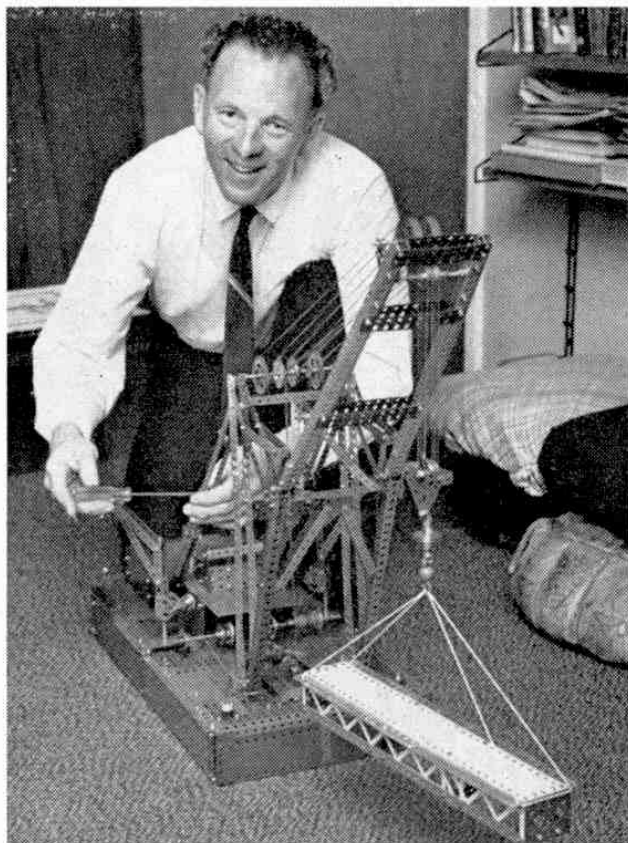

Pictured here making final adjustments to his Japanese Floating Crane model is Mr. Ben Oostewegel of Western Springs, Auckland, New Zealand.

Front-wheel Drive Unit

OUR FIRST and, in fact, our only constructional offering this month, is a front wheel drive unit, designed by Edward Pritchard of Poleshill, Sarratt, Herts. It is, as can be seen from the accompanying photographs, a reasonably large and pretty rugged example of this type of mechanism which consequently makes it suitable for inclusion in complicated models.

A differential is first built up from two $2\frac{1}{2} \times 1\frac{1}{2}$ in. Flanged Plates 1, joined at each end by a $1\frac{1}{2} \times 1\frac{1}{2}$ in. Flat Plate 2. A $2\frac{1}{2}$ in. Rod is mounted in the centre of one of these Plates and fitted with two Washers and a $\frac{3}{4}$ in. Contrate Wheel 3 after which it is inserted, loose, part-way into the longitudinal bore of a Coupling

Designed by Edward Pritchard of Poleshill, Sarratt, Herts, this heavy-duty Front Wheel Drive Mechanism is ideal for use in large motor vehicles.

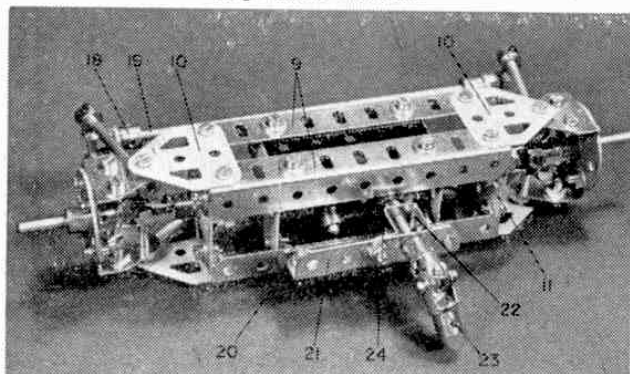

AMONG THE MODEL BUILDERS

with Spanner

4. Mounted in the other Flat Plate is a 3 in. Rod fitted with another two Washers, a $1\frac{1}{2}$ in. Contrate Wheel 5, loose on the Rod but held in place by a Collar, and a second $\frac{3}{4}$ in. Contrate Wheel 6, the Rod then being inserted free into the other end of Coupling 4. Note that the centre transverse bore of the Coupling must be left clear as, fixed in this, is a $1\frac{1}{2}$ in. Rod on each end of which a Collar 7 is secured. Each of these Collars is connected to Contrate Wheel 5 by a $1\frac{1}{2}$ in. Bolt held by a Nut in the face of the Contrate and screwed into one tapped bore of the Collar. The $1\frac{1}{2}$ in. Rod, incidentally, is secured by two Pivot Bolts screwed into the central tapped bores of Coupling 4, each Pivot Bolt being fitted with a free-running $\frac{3}{4}$ in. Pinion 8, in constant mesh with Contrates 3 and 6.

Now fixed to each Flanged Plate are two $4\frac{1}{2}$ in. Angle Girders 9, joined at each end by a $1\frac{1}{2}$ in. Angle Girder and a Flat Trunnion 10. The $1\frac{1}{2}$ in. Girders are in turn joined by $1\frac{1}{2} \times 1\frac{1}{2}$ in. Flat Plates 11, the above-mentioned $2\frac{1}{2}$ and 3 in. Rods passing through the centre holes of these Plates. The Rods are each fitted with a Universal Coupling 12, in the other boss of which a $1\frac{1}{2}$ in. Rod 13 is fixed. A Threaded Pin 14 is secured to lower Flat Trunnions 10.

Two identical arrangements are next each built up from a 6-hole Bush Wheel 15, to which four Angle Brackets are bolted, the Angle Brackets being arranged in pairs placed diametrically opposite each other. A 1 in. Triangular Plate 16 is fixed to each pair of Angle Brackets, then the arrangements are mounted loose on Rods 13, Threaded Pins 14 engaging with the apex holes of the Triangular Plates. The apexes of Flat Trunnions 10 and the upper Triangular Plates, on the other hand, are lock-nutted together, the place of the lower lock-nuts being taken by Short Couplings 17, in each of which a 2 in. Rod is fixed. These Rods are joined, via Collars and Small Fork Pieces 18, by a $6\frac{1}{2}$ in. Rod 19.

PARTS REQUIRED

4-5	2-17	58-37b	4-77
4-9a	4-18a	29-38	2-111d
2-9d	2-24b	1-45	2-115
4-9f	2-25	2-51	2-116a
8-12	1-26	5-59	4-126a
1-14	1-28	1-63	3-140
1-16a	2-29	2-63d	4-147b
1-16b	61-37a	4-74	

To complete the mechanism, a $2\frac{1}{2}$ in. Angle Girder 20 is bolted to lower rear Girder 9, the two Girders being spaced apart by two $2\frac{1}{2}$ in. Strips. Another two $2\frac{1}{2}$ in. Strips are used to space a second $2\frac{1}{2}$ in. Angle

Girder 21 from the horizontal flange of Girder 20, then a Double Bent Strip 22 is secured to the vertical flange of the latter Girder. Journalled in this Double Bent Strip and Girder 21 is a $1\frac{1}{2}$ in. Rod, held in place by another Universal Coupling 23 and a $\frac{1}{2}$ in. Pinion 24. Pinion 24 meshes with Contrate 5.

News from New Zealand

Passing onto a different subject, I have often stressed the world-wide appeal of Meccano in these pages, but I must confess that overseas enthusiasts do not seem to appear too often in *Meccano Magazine*. Recently, we have been trying to rectify the situation and already have managed to mention Australia in the February issue with Switzerland following in March. Now it is the turn of New Zealand—a beautiful country with a large and extremely keen Meccano following. One of the keenest enthusiasts out there is Mr. Ben J. Oostewegel of Western Springs, Auckland, seen in one of the accompanying photographs with a model of a Japanese Floating Crane he has built.

Ben was actually born in Holland where he took up Meccano as a hobby when he was 9 years old. However, like so many other people, he was forced to abandon it during the last war and was unable to take it up again until some years after he had emigrated to New Zealand, via Indonesia. Take it up again he did, though, and has been at it ever since. The model appearing in the photo is based on one of several large Japanese-built floating cranes that were being used in Auckland Harbour to help in the construction of an extension to the Auckland Harbour Bridge when Mr. Oostewegel saw them. It took him some 50 hours and more than 1,000 parts to complete the model which is built up on a "hull" measuring 25 in. long by $12\frac{1}{2}$ in. wide by 3 in. deep. The height of the jib support is $12\frac{1}{2}$ in., while the jib itself is $18\frac{1}{2}$ in. long. Total height is 3 ft. 2 in. with the jib fully raised.

Authentic luffing and hoisting movements are incorporated, both the controlling winches being driven by a Power Drive Unit through a twin-branch gearbox incorporating a clutch and automatic brake. The motor is housed at one end of the crane, under the roof of the "cabins", and is connected by a Universal Coupling to the gearbox situated under the "deck-house". Bevel gearing transfers the drive from the gearbox to the winches.

It is an interesting fact, incidentally, that Mr. Oostewegel built his model up from plans of the full-size crane, kindly supplied by I.H.I. Ltd., the bridge firm, on the strict understanding that they would be allowed to see the finished model. See it, they did, and were so impressed with it that they have commissioned Mr. Oostewegel to build another one specially for them! We offer you our sincere congratulations, Mr. Oostewegel.

Christchurch Meccano Club

While we are in New Zealand, mention must be made of the highly successful Christchurch Meccano Club, the first and now the only club of its type in New Zealand. Its history actually goes as far back as 1929 when Whales's Meccano Club was formed at Whales' shop on the corner of High and Manchester Streets in Christchurch. Early in 1930, the name was changed to the present Christchurch Meccano Club although, by this time, the club was not exactly alone as several similar organisations had been formed in different parts of the country.

Like Meccano Clubs everywhere, however, the New Zealand bodies were hard-hit during the last war—so

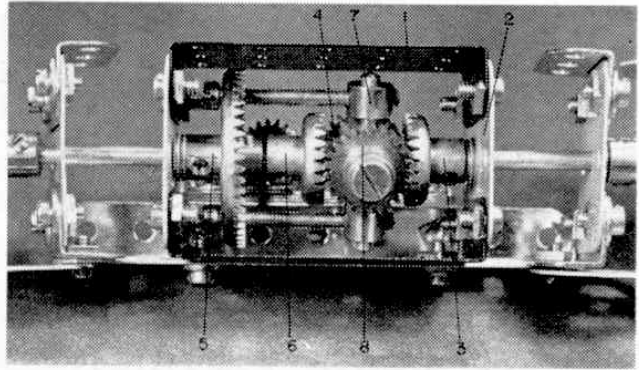

A close-up view of the differential incorporated in the Front Wheel Drive unit. Space for the $1\frac{1}{2}$ in. Rod carrying Collars 7 is obtained by making full use of the elongated holes in Flanged Plates 1.

much so, in fact, that, when the war ended, only the Christchurch Club remained in existence. Other clubs have subsequently been formed, unfortunately without a great deal of success, but the Christchurch Club has flourished until, today, it can boast a keen, dedicated membership. A sure sign of success is the fact that the Club had its own stand at the last New Zealand Industries Fair which is one of the most attended public exhibitions in the country. It would be impossible to mention all the exhibits here, so I must content myself with a few words about one of the models which excited particular interest, although all the members of the Club who helped to make the Stand a success are to be congratulated.

The model in question is a $\frac{1}{8}$ th scale reproduction of a New Zealand Railways Ec Locomotive as used on the Christchurch-Lyttelton line. It was built by draughtsman, Mr. Sid Kennedy in something like 200 working hours which time will give you some idea of just how much care and work can go into building an advanced Meccano model. An estimated 7,100 parts were used in its construction, Nuts, Bolts and Washers accounting for no less than 4,500 of them. Because of its size—4 ft. 10 in. long—it has been possible to include authentic detail, not only in general lines, but also in such items as doors, pipes, handrails, leaf-spring suspension and automatic couplings, etc. For what it's worth, my verdict is a superb, true-to-scale, solid model—and solid it certainly is. It weighs a staggering 62 lb!

The stub axle and Universal Coupling of Mr. Edward's mechanism in close-up. All Rods must be entirely free-running in their bearings.

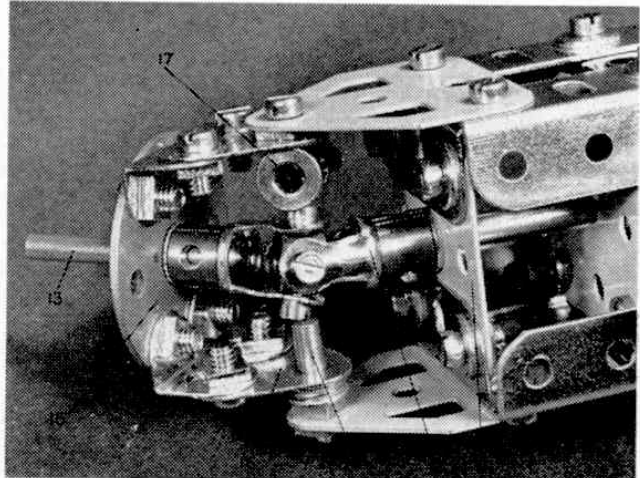

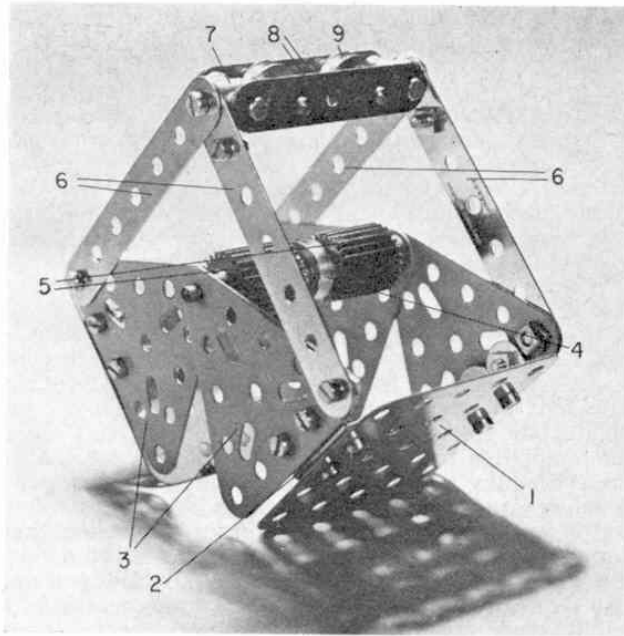

A simple, but extremely efficient Priestman Grab which can be opened automatically from the control box of its parent model.

Front-Wheel-Drive unit

WITH ALL the fuss that is made over front-wheel-driven cars, these days, you might be forgiven for thinking that front-wheel-drive was something new. In actual fact, of course, it isn't. It's been going for almost as long as the motor car, itself! Meccano Limited even published details of a genuine miniature front-wheel-drive system something like 40 years ago and, since then, similar mechanisms have appeared in the M.M. from time to time. Featured here is another unit in the same series, the work of Mr. Pat Lewis of Formby, Lancs., and this example is of particular interest because of the first-rate swivel joints it incorporates. These joints allow a positive flexible drive to the wheels and also allow the wheels themselves to move through a considerably larger angle than is the case in most other Meccano front-wheel-drive units.

To ensure smooth running, care should be taken with construction. A frame is first produced from two $2\frac{1}{2} \times \frac{1}{2}$ in. Double Angle Strips 1, to each of which a Flat Trunnion 2 is bolted, the Double Angle Strips then being connected together, as shown, by two $5\frac{1}{2}$ in. Strips 3, the Strips projecting two holes beyond the Double Angle Strips. Journalled in the Double

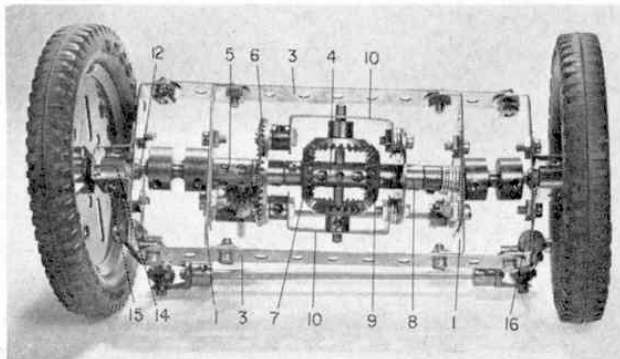

An effective Front-Wheel-Drive Unit designed by Mr. Pat Lewis of Formby, Lancashire.

AMONG THE MODEL BUILDERS

Readers' Meccano ideas described by Spanner

Angle Strips and in part of the longitudinal bore of a Coupling 4 are two 2 in. Rods, one Rod carrying a fixing Collar outside its Double Angle Strip and a Short Coupling 5, two Washers, a $1\frac{1}{2}$ in. Bevel Gear 6 and a $\frac{7}{8}$ in. Bevel Gear 7 inside its Double Angle Strip. The other Rod also carries a fixing Collar outside its Double Angle Strip, while, inside, it carries five Washers, another Collar, an 8-hole Bush Wheel 8 and a $\frac{7}{8}$ in. Bevel Gear 9. Note that Short Coupling 5, Bevel Gear 6 and Bush Wheel 8 are free to turn on the Rods and that the external fixing Collars are held in place by *Set Screws*.

The faces of Bevel 6 and Bush Wheel 8 are now joined by two $1\frac{1}{2} \times \frac{1}{2}$ in. Double Angle Strips 10, these being spaced from the Bush Wheel by two Washers on each securing Bolt and spaced from the Bevel by a Collar and one Washer on each Bolt. Mounted in these Double Angle Strips, but fixed in the centre transverse bore of Coupling 4, is a 2 in. Rod on which two $\frac{7}{8}$ in. Bevel Gears 11 are secured, these Gears meshing with Gears 7 and 9.

Turning to the ball joints, these are both similarly built up from a Handrail Support 12, passed free through a $2\frac{1}{2} \times \frac{1}{2}$ in. Double Angle Strip 13 and locked by a Nut in an Adaptor for Screwed Rod 14. (The Double Angle Strip must not be mounted in place in the unit at this stage). A Double Bent Strip 15 is slipped over the Adaptor and bolted to the Double Angle Strip. A *Set Screw* is screwed into the head of the Handrail Support, after which the Support is inserted, unfixed, into one end of a Socket Coupling, the other end of which is positioned, also unfixed, over one or other of the external fixing Collars. The lugs of the Double Angle Strip are then lock-nutted to the ends of Strips 3. Secured to each Double Angle Strip is a Slotted Coupling 16, in the longitudinal bore of which a $1\frac{1}{2}$ in. Rod is fixed. A Swivel Bearing 17, is mounted on the end of each Rod, the Swivel Bearings then being connected by a 5 in. Rod.

Each Flat Trunnion 2 is now extended one hole by a $1\frac{1}{2}$ in. Strip, as shown. Fixed to the Strip nearest Bevel Gear 6, but spaced from it by a Washer, is a Threaded Coupling 18, in the longitudinal bore of which a $3\frac{1}{2}$ in. Rod is held, this Rod also being held by Collars in the other $1\frac{1}{2}$ in. Strip. Journalled in the centre transverse bore of the Threaded Coupling and in the appropriate transverse bore of Short Coupling 5, is a $2\frac{1}{2}$ in. Rod 19, held in place by a Collar and carrying a $\frac{1}{2}$ in. Bevel Gear 20. This Bevel meshes with Bevel 6.

Finally, 3 in. Pulleys with Motor Tyres are mounted, free, on Adaptors for Screwed Rod 14, where they are held by Collars. The Unit is of course driven through Rod 19. The Set Screws in the Collar and Handrail Support inside each Socket Coupling, by the way, engage in the slots in the Socket Coupling to enable the drive to be passed on to the wheels.

PARTS REQUIRED

2-2	1-24	2-48	2-111c
2-6a	4-30	4-48a	2-126a
1-15	1-30a	10-59	2-136
1-16	1-30c	1-63	2-142b
1-16a	30-37a	2-63b	2-165
3-17	22-37b	1-63c	2-171
2-18a	16-38	1-63d	2-173a
2-19b	2-45	2-111a	

Priestman Grab

On an entirely different subject, I recently noticed a fairly small excavator in Meccano's Model-building Department which included a simple, but extremely effective Bucket Grab, controlled by an equally simple and effective operating mechanism. I felt that both the Grab and control mechanism would be of interest to crane builders and so I would like to include slightly modified versions of them here.

To being with, the actual Bucket is easily produced from two $2\frac{1}{2} \times 2\frac{1}{2}$ in. Flat Plates 1, each attached by two $2\frac{1}{2} \times \frac{1}{2}$ in. Double Angle Strips 2 to two $2\frac{1}{2}$ in. Triangular Plates 3. The apexes of each pair of Triangular Plates are pivotally joined by a 3 in. Rod, in the centre of which a free-running $\frac{1}{2}$ in. loose Pulley 4 is mounted. Also mounted on the Rod should be a number of parts to serve as weights for opening the Bucket, and we used two $\frac{3}{4}$ in. faced $\frac{3}{4}$ in. diameter Pinions 5 plus half-a-dozen Washers.

Lock-nutted to the Triangular Plates are four $3\frac{1}{2}$ in. Strips 6, these being brought together in pairs at the top and pivotally attached to two Threaded Bosses 7. Fixed between these Threaded Bosses through their transverse bores are two $2\frac{1}{2}$ in. Strips 8, spaced from the Bosses by two Washers on the shank of each securing Bolt, and in the Strips are journalled two 1 in. Rods, each carrying two Washers and a $\frac{1}{2}$ in. fixed Pulley 9. When the Grab is lifted by Strips 8, the Bucket should open under the weight of the parts on the hinge Rod.

In the case of the control mechanism, the mounting would depend on the parent model, but, for demonstration purposes, we used two $2\frac{1}{2} \times 2\frac{1}{2}$ in. Flat Plates bolted to a $5\frac{1}{2} \times 2\frac{1}{2}$ in. Flanged Plate. Journalled in the Flat Plates are two $4\frac{1}{2}$ in. Rods 10 and 11, Rod 10 carrying four fixed 8-hole Bush Wheels 12, 13, 14 and 15, and Rod 11 carrying a Coupling 16 in which a $1\frac{1}{2}$ in. Rod 17 is fixed. Free to turn and slide on this last Rod is a $\frac{1}{2}$ in. loose Pulley 18 that is prevented from coming off the Rod by a Collar. Rod 11 is held in place by Collars and is turned by means of a 1 in. Pulley 19, fitted with a Rubber Ring, while Rod 10 is turned by a handwheel built up from an 8-hole Bush Wheel 20 fitted with a $\frac{1}{2}$ in. Bolt. A 1 in. Pulley with Motor Tyre 21 is also fixed on Rod 10, the Tyre rubbing against one of the Flat Plates to serve as a friction brake.

Bush Wheels 12, 13, 14 and 15 make up two winding drums, Bush Wheels 12 and 13 serving as the end checks of drum 1 and Bush Wheels 14 and 15 as the end checks of Drum 2. The Cord from drum 1 is passed beneath Pulley 18, is taken up and around a

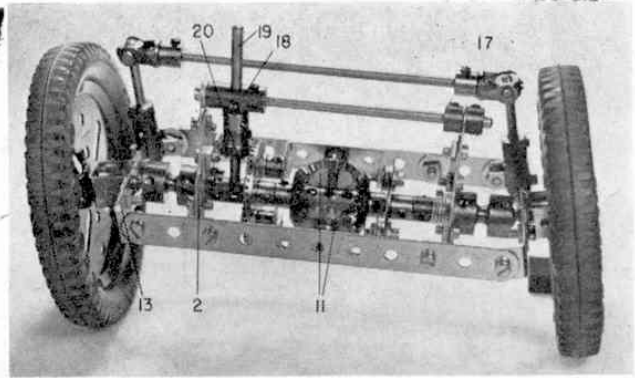

Another view of the Front-Wheel-Drive Unit showing the driving axle.

Pulley in the jib-head of the parent model, then is taken down and beneath one Pulley 9; along and up around the other Pulley 9, to be finally tied to the jib of the parent model. The Cord from drum 2, on the other hand, is taken straight up and over a second Pulley in the jib-head; is brought down and around Pulley 4, then is taken up and also tied to the parent model.

In operation, the Grab can be raised and lowered by turning handwheel 20, while the Bucket can be opened by turning Pulley 19 in a clockwise direction, this causing Pulley 18 to press against the Cord from Drum 1, thus, in effect, shortening the Cord. The other Cord, however, remains the same length, therefore the weights on the Bucket hinge Rod cause the Bucket to open.

PARTS REQUIRED

Bucket Grab		Control Mechanism	
4-3	26-37a	2-15a	4-37b
2-5	28-37b	1-18a	1-52
1-16b	22-38	2-22	3-59
2-18b	4-48a	1-23	1-63
1-23	2-64	5-24	2-72
2-23a	4-76	6-37a	1-111a
2-25b			1-142c
			1-155

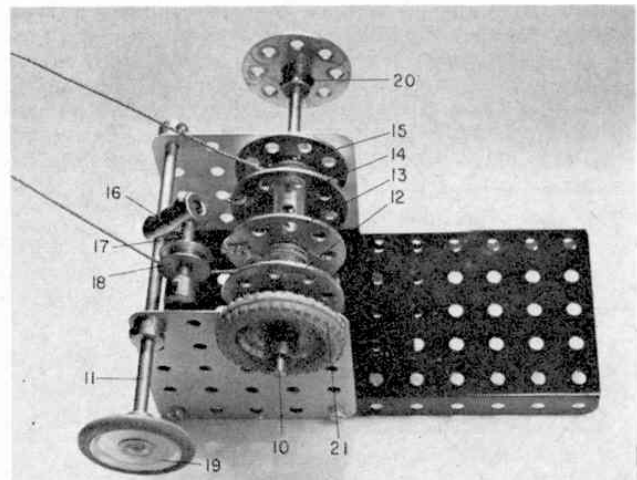

A useful winding unit and control mechanism specially designed for use with the Priestman Grab described in this article.

AMONG THE MODEL- BUILDERS

with 'Spanner'

Front-Wheel Drive

In the course of our day-to-day correspondence with modellers we are often asked to supply details of particular Meccano mechanisms to meet individual model-building requirements and, over a period of time, these requests obviously enable us to see which mechanisms tend to be more useful than others. One of the most frequently requested items is a good Front-wheel Drive system, and therefore I am pleased to feature here just such a mechanism, in the sure knowledge that it will be of value to a large number of readers. Full credit for its design goes to Mr. Brian Edwards of Kempston, Bedford and my thanks go to Bert Love for the accompanying photographs of Brian's unit and the following description of it. The unit, incidentally, is of special interest in that it incorporates an effective wishbone suspension system as well as rack steering.

Dealing with the suspension first, the "wishbone" is formed from two $2\frac{1}{2}$ in. Strips 8 which are secured to

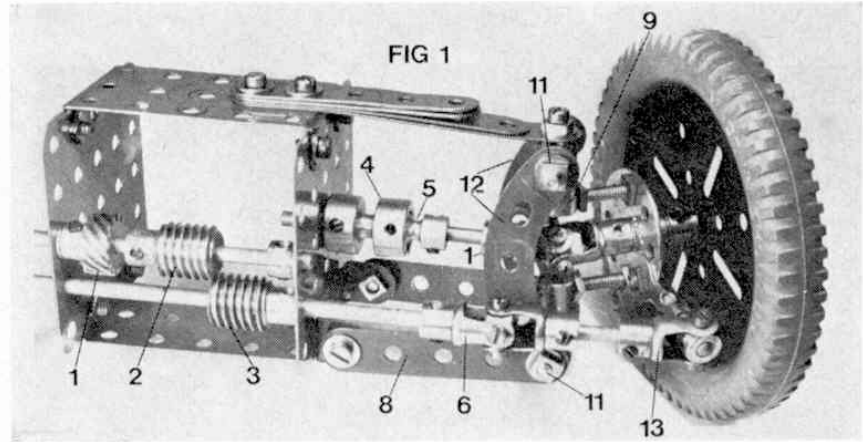

A Front-Wheel Drive Mechanism, designed and built by Brian Edwards of Kempston, Bedford, which includes wishbone suspension and rack steering. The required differential has been omitted to aid description.

a $1\frac{1}{2} \times \frac{1}{2}$ in. Double Angle Strip on the $2\frac{1}{2} \times 2\frac{1}{2}$ in. Flat Plate forming part of the central drive box. The Strips are pivoted fairly tightly by lock-nutted Bolts. Overhead cantilever springing is supplied by a series of Strips of various lengths, sandwiched to make a leaf spring 16, bolted to the upper part of the central drive box, while kingpin bearings are provided by a pair of Couplings 10 which are carried on Threaded Pins attached to both ends of two $2\frac{1}{2}$ in. Stepped Curved Strips 12. The Threaded Pins are clamped inside the Couplings by Grub Screws, but are carefully adjusted by packing with Washers to keep the central transverse tapped bores in the Couplings free from binding.

Outside lock-nuts are provided on the lower Threaded Pin to clamp two $2\frac{1}{2}$ in. Strips 8 fairly tightly to Curved Strips 12, with the aid of a Washer, to effectively simulate shock absorbers. The overhead leaf spring is secured to the central tapped bore of the upper Coupling

by a standard Bolt, firmly secured by a lock-nut and Washer.

The two kingpins 9 are provided by Rod Sockets which have most of their shanks screwed into the central tapped bores of the Couplings, but with sufficient slack to permit steering angle movement. An 8-hole Bush Wheel forms the wheel hub, this being locked to the kingpin Rod Sockets by two $\frac{3}{4}$ in. Bolts, each fitted with two lock-nuts. A Rod and Strip Connector, extended by a 1 in. Rod, is bolted to the Bush Wheel, as shown, to form the steering arm, which is pivoted in a Swivel Bearing 13.

To ensure flexibility when the suspension moves, the steering track rod requires a flexible joint, provided in this case by a Universal Coupling 6 which is fixed to the Swivel Bearing by a further 1 in. Rod. Secured in the other side of the Universal Coupling is a 5 in. Rod 15, carrying a Worm Gear 3. This Worm does not rotate, but serves, instead, as the steering rack. Drive to this rack comes from another Worm 2, mounted on a Rod above it, this Rod being turned by means of a $\frac{1}{2}$ in. Helical Gear 1, which is itself turned under operating conditions by a $1\frac{1}{2}$ in. Helical Gear mounted on the steering column. Worm 2 must of course make contact with Worm 3 in order for the steering to operate successfully.

Coming to the drive system, this would be taken initially to a differential mechanism mounted in the central drive box. The customary Meccano differential would be perfectly adequate here, and as this mechanism has been frequently described in the M.M., it has been omitted from the demonstration unit

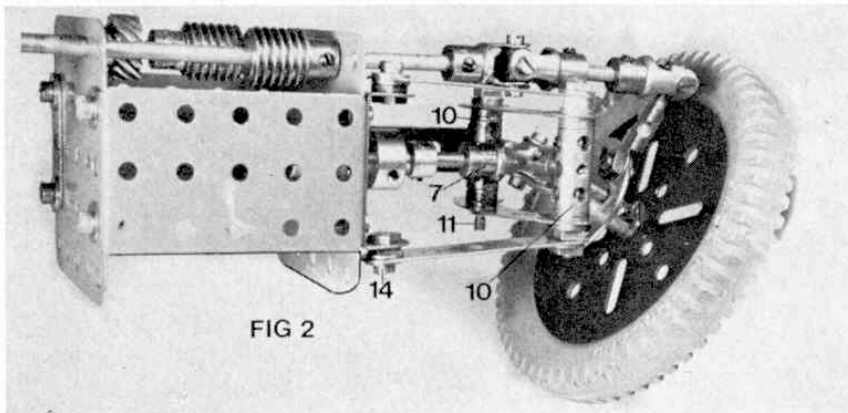
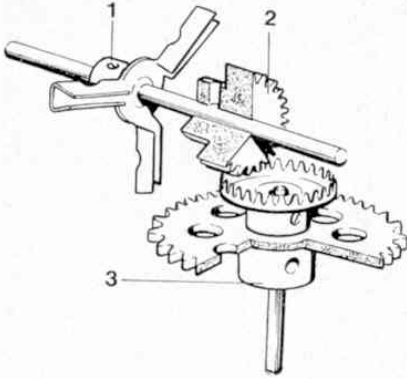

FIG 2

An underside view of the Front-wheel Drive Mechanism showing the layout of the kingpin bearings.

A simple, although unorthodox idea suggested by Bob Hauton of Lincoln for obtaining a 12:1 reduction ratio for clock hands by using a 3-way Rod Connector meshing with a 36-teeth Sprocket Wheel is sketched below. On the right is another simple idea from this modeller, an interesting Intermittent Motion Mechanism.



illustrated so as not to complicate matters unnecessarily. Mounted on each output shaft of the differential is a Socket Coupling 4, forming the first part of a flexible drive which is taken up by a Handrail Coupling 5, its head fitted with the special Keyway Bolt to make a neat fit in the slot of the Socket Coupling and thus allow a positive drive with adequate flexibility. A 1 in. Rod

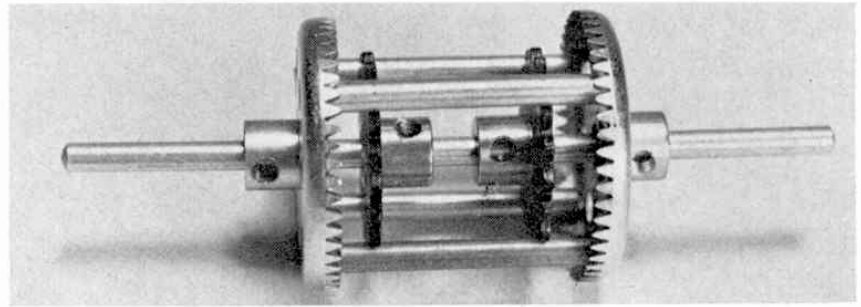

passes the drive on to a Universal Coupling 7, critically positioned so that its central spider is in axial alignment with the kingpin bearings above and below. Finally, a further 1 in. Rod passes through the boss of the Bush Wheel to link the Universal Coupling with the road wheel. The following parts list applies to a full two-sided unit, but does not include the differential or drive shafts, the latter depending on the assembly of the differential.

PARTS REQUIRED

2-3	2-24	1-59	2-136a
2-4	2-32	4-63	4-140
8-5	32-37a	2-72	2-142b
2-15	16-37b	4-90a	2-165
1-16	64-38	4-111	2-171
4-18b	2-48	4-111c	4-179
2-19b	2-51	8-115	1-211a
			2-212

Useful Hints

Next, we move on to two or three quick hints, supplied by Mr. Bob Hauton of Lincoln. First in line is an Intermittent Drive System using a 3-way Rod Connector with boss, engaging with the teeth of an 18-teeth or 36-teeth Sprocket Wheel at right angles. Bob points out, in fact, that by using a 36-teeth Sprocket, it is possible to make a simple—if unorthodox—12:1 ratio for clock hands, as shown in the accompanying sketch. The Rod Connector 1 is fixed, along with a 25-teeth Pinion 2, on the driven Rod of the clock. In mesh with the Pinion is a $\frac{3}{4}$ in. Contrate Wheel secured on the minute hand Rod, this Rod also carrying a loose 36-teeth Sprocket Wheel 3, to the boss of which the hour hand would be fixed. The Rod Connector engages with the teeth of this Sprocket.

Bob's second idea will be of interest to Meccanograph builders. Four of the Large-toothed Quad-

rants introduced last year, he says, can be bolted to the $9\frac{1}{8}$ in. Flanged Ring, which in turn can be secured to a suitable wood table to make an ideal design table for Meccanograph models. A really positive drive can then be fed to the table through the large Quadrant Pinion.

Suggestion No. 3 takes the form of another Intermittent Drive Unit, but one with a wide variety of uses over a wide area of operation. Any number of Rods from one to eighteen can be mounted on the teeth of two 1 in. Sprocket Wheels, being held in place by "capping" the ends of the Rods with $1\frac{1}{2}$ in. Contrate Wheels, as shown in the photograph. All the Rods must, of course, be of a similar length, but theoretically this length can be anything from 1 in. upwards!

Push Bike from New Zealand

Last of all, this month, I would like to draw attention to the very good Bicycle model illustrated in our remaining photograph. This was designed and built by 13 year-old Neil Pluck of Woolston, Christchurch, New Zealand, who managed to complete it in a total of approximately 10 hours building time. An enthusiastic member of the Christchurch Meccano Club, Neil entered the Bike in a recent Club competition and succeeded in carrying off top marks with it.

The rather unusual view of the model in the illustration, by the way, was chosen by the photographer to show off its realistic proportions and sturdy construction to the best advantage. It shows well the amount of detail that has been incorporated in the model and I would particularly like to congratulate Neil on the main framework. There is a tendency, when building a bike frame in Meccano, to use only Strips which obviously leaves an unrealistic gap between the two sides of the frame. Neil has overcome the problem extremely well by enclosing the space with Sleeve Pieces and I think everyone will agree that they make all the difference. Well done, Neil!

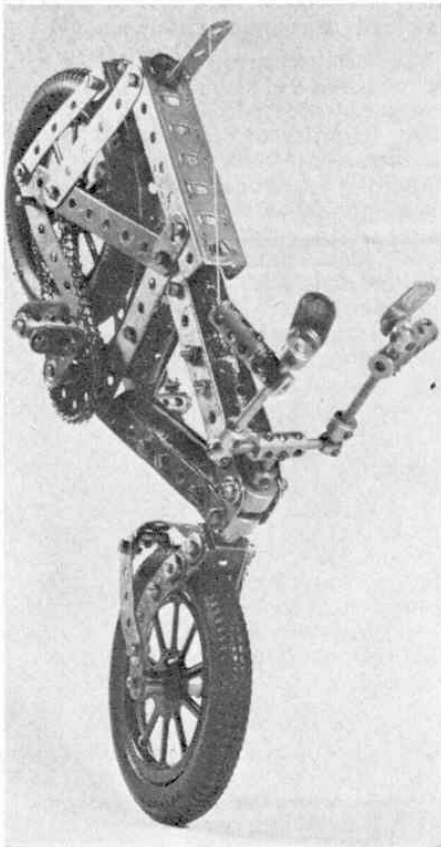

A rather unusual, but descriptive view of a first-class Bicycle designed and built by 13-year old Neil Pluck of Woolston, Christchurch, New Zealand.

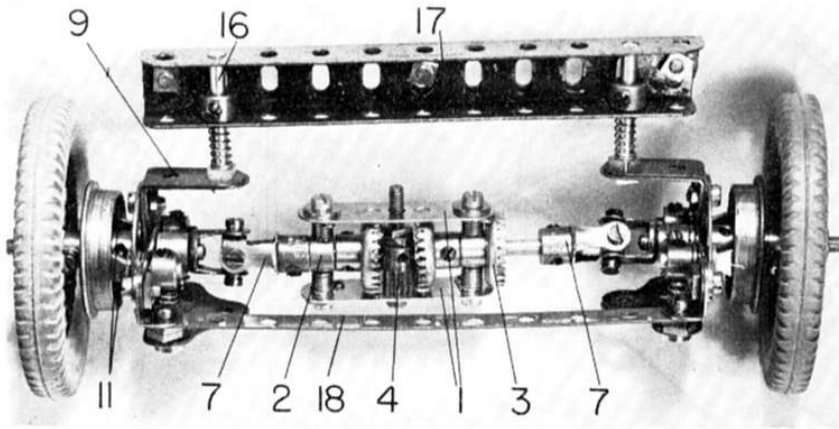

Among the Model-Builders

with 'Spanner'

THROUGHOUT history, distinguished men of the times have been honoured with popular titles, bestowed on them by their contemporaries. The Roman commander Alexander, for example, was known as "The Great", or King Richard I as "The Lionheart" and, more recently, Alexander Graham Bell became famous as the "Father of the Telephone". If it was customary to bestow such titles on Meccano modellers today, one man who would undoubtedly deserve recognition is James Grady of Dundee, Scotland, and the title I would give him is "Champion of the Small-Scale Vehicle Builders"!

James is fast becoming an expert on useful mechanisms for small motor vehicles and you can bet your last new halfpenny that, if we feature in these pages a motor chassis mechanism designed for use with 3 in. Pulleys and Tyres, it won't be long before James turns up with a similar, but much more compact mechanism suitable

for smaller wheels, and hence, smaller models. As James himself said in a recent letter, "My favourite battle cry is "Why should the lads with the big Sets have all the fun?" Why, indeed, James, and my sincere thanks go to you for all the valuable material your crusade has led you to design.

To get down to business, in last October's M.M. we featured a front-wheel drive mechanism using 3 in. Pulleys with Tyres as road wheels and, sure enough, James has now supplied me with a smaller, yet very comprehensive Unit of a similar type. It is shown in the accompanying illustrations fitted with 2 in. Pulleys and Tyres for road wheels, but it can also be used with 1½ in. Pulleys.

It will be noticed by regular readers that the Unit makes use of a differential and a braking system, also designed by James, which have previously been mentioned in these pages. The differential consists of two of the

latest style of 2 in. Strips 1 which are attached by ¼ in. Bolts at one end to a Collar 2, a Cord Anchoring Spring on the shank of each Bolt and a Washer under the bolthead acting as spacers. At their other ends, the Strips are similarly attached to, but spaced from, a ¼ in. Contrate wheel 3, care being taken that the fixing ¼ in. Bolts do not foul the central bore of the Contrate. (This also applies to Collar 2).

Mounted in the central holes of the Strips is a 1½ in. Bolt, on which a ⅞ in. Pinion 4 is free to rotate, but is prevented from sliding on the Bolt shank by two lock-nuts. In constant mesh with the Pinion are two ¼ in. Contrate Wheels 5, one fixed on a 1 in. Rod journalled free in Collar 2, and the other on a 1½ in. Rod 6, journalled free in Contrate 3. Secured on the outside end of each of these Rods is a Universal Coupling 7.

Each hub assembly is similarly built up from an 8-hole Bush Wheel to which a 1 × 1 in. Angle Bracket 9 and a 1 × ½ in. Angle Bracket are bolted, one on top of the other for strength. A 2 in. Strip 10, at right-angles to the lug of Bracket 8, is also secured to the face of the Bush Wheel, but note that, instead of Bolts, this is fixed with two Centre Forks 11 and Collars 12. Each Centre Fork is first fitted with a Washer, then the shank of the Fork is inserted through a hole in the Bush Wheel face, is fitted with two packing Washers, passed through

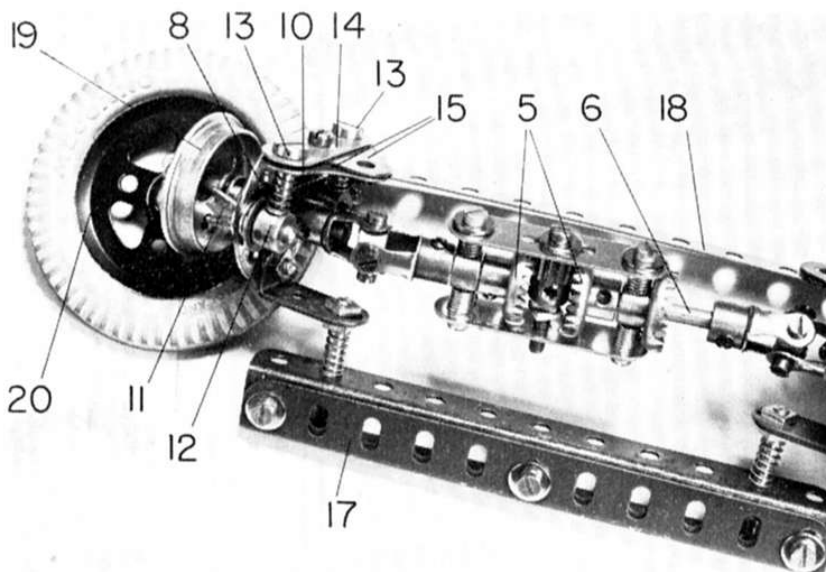

Top, a compact but highly effective Front-wheel Drive Unit designed by Mr. James Grady of Dundee, Scotland, for use in smaller motor vehicles. It will operate with 1½ in. or 2 in. Pulleys and Tyres as road wheels.

Left, a close-up view of Mr. Grady's first Front-wheel Drive Unit showing the brake drum partially removed.

First of Mr. Grady's "simple" Front-wheel Drive Units, suitable for 1½ in. Pulleys with Tyres. Although it does not incorporate a differential, it is nonetheless interesting in operation and Meccano historians will also be interested in the very old-design Tyre Mr. Grady has fitted for the photograph!

the respective hole of Strip 10 and is finally secured with one Collar 12. The "empty" threaded bores of Collars 12 must point vertically downwards. Screwed into these bores are two Pivot Bolts 13, each fitted with a Compression Spring and the two are connected by a 1½ in. Strip 14 and two 1 in. Corner Brackets 15, arranged as shown to form a bell shape. The apex hole of the "bell" should be in line with the end hole in the spare lug of Angle Bracket 9. A Long Threaded Pin 16 is then tightly fixed in this end hole of the Bracket to complete the hub.

With both hubs similarly built, a Compression Spring is added to Pin 16 in each assembly, then a 5½ in. "U"-section channel girder 17 is mounted on the Pins, being held in place by a Collar mounted on each Pin between the flanges of the girder. The girder itself is built up from two 5½ in. Angle Girders. Compression Springs on the Threaded Pins, of course, serve as a good independent suspension system. The rear ends of Strips 10 in each hub are connected by a 5½ in. Narrow Strip 18, lock-nutted to Angle Brackets attached to Strips 10, to serve as the steering tie-bar.

A 2 in. Rod, serving as the stub axle, is next passed, free, through the boss of each Bush Wheel 8, to be fixed in the free end of one or other Universal Couplings 7. A 1½ in. Flanged Wheel 19 is mounted on the Rod with its flange over the heads of Centre Forks 11, then the road wheel 20 is secured in place.

Under operating conditions, drive is taken to Contrate Wheel 3, while a suitable brake linkage (Strip or Cord) is connected to the apexes of the "bell" assemblies. Movement of the bell assemblies causes Centre Forks 11 to turn, thus bringing their heads into contact with the flanges of Flanged Wheels 19 to give effective braking. The Compression Springs on Pivot Bolts 13 ensure automatic brake release when braking pressure is released.

The compact design of this, the smallest of Mr. Grady's Front-wheel Drive Units, is evident from this illustration. The mechanism is suitable for use with 1 in. Pulleys and Tyres as road wheels, although "modellers' licence" has again been used in that there is no differential.

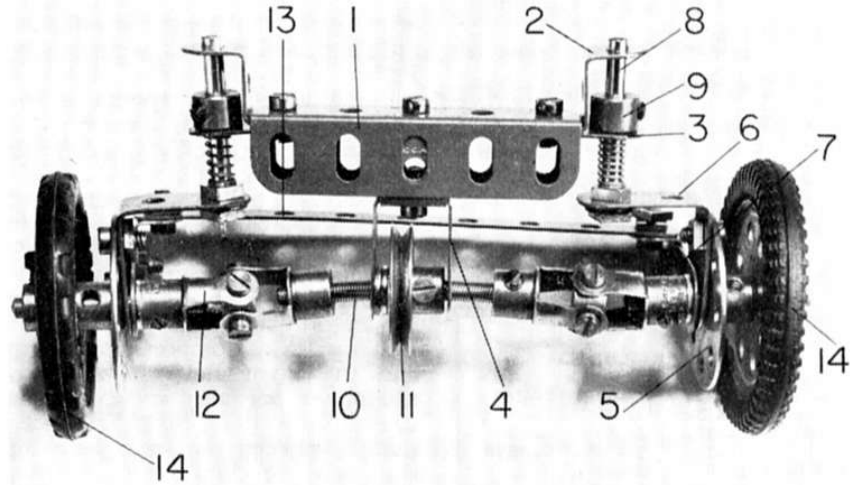

PARTS REQUIRED

4-6	1-18a	15-37a	2-115a
2-6a	1-18b	11-37b	6-120b
2-9	2-20	20-38	4-133a
2-12	2-20a	7-59	2-140
2-12a	2-24	4-65	2-142a
2-12b	1-26c	4-111c	4-147b
2-17	3-29	1-111d	4-176
			1-235f

Simple Units

Mr. Grady has also supplied me with two considerably less complicated Front Wheel Drive Units which, although they are not engineeringly correct in that they do not incorporate differentials, could nonetheless be used in simple models where the privilege of "modellers' licence" may be invoked. The first, designed for 1½ in. Pulley-based road wheels, consists of a "U"-section cross-member 1, built up from two 2½ in. Angle Girders connected together, with each end connecting Bolt also holding a ½ in. Reversed Angle Bracket 2 and a 3½ in. Strip 3 in place. A centre connecting Bolt holds a Double Bracket in place by

one lug, a 1 × ½ in. Double Bracket 4 being bolted to the lower lug of this Double Bracket as shown.

Each hub assembly is supplied by an 8-hole Bush Wheel 5, to which a 1 × 1 in. Angle Bracket 6 and a 1½ in. Strip 7 are bolted, the latter spaced from the Bush Wheel by a Washer. Fixed in the end hole in the spare lug of Bracket 6 is a Long Threaded Pin 8, on which a Compression Spring is mounted, the Pin then being inserted in the spare lug of Reversed Angle Bracket 2 and the end hole of Strip 3, where it is held in place by a Collar 9. This arrangement again provides effective independent suspension.

Journalled in the end holes in the lugs of Double Bracket 4 is a Flexible Coupling Unit 10, held in place by a 1 in. Pulley 11 between the lugs of the Bracket, three Washers at one side being used for spacing purposes. A Universal Coupling 12 is fixed on each end of the Flexible Coupling, the stub axle—a 1½ in. Rod—being passed, free, through the centre of the hub and into the other side of the Universal Coupling, where it is fixed in

