



The ideas printed in the "Suggestions Section" should prove a real help to thousands of Meccano enthusiasts. Often we receive letters from readers who describe how they have solved some knotty problem or evolved an interesting model after studying some of the ideas that have appeared. We shall always be pleased to receive further contributions for the "Suggestions Section." Cash payments are made for Suggestions published showing special merit. Contributions should be accompanied by clear photographs or drawings and should be addressed to "Spanner," c/o The "Meccano Magazine."

## (120)—Siemens' Chronometric Governor

(S. Morris, Paddington, W.10)

IN almost every type of engine, certainly in all steam engines, an efficient means of regulating the speed must be provided.

A simple engine of the piston and cylinder type can, of course, be regulated by hand, but for the finer adjustment of speed some form of automatic governor is essential, and as the size and power of the engine increases, so the governor mechanism becomes more elaborate. A simple case that will show the importance of efficient governing is provided by the marine engine. In a rough sea the ship's propeller may be lifted completely out of the water, owing to the pitching of the vessel, with the result that the engines are freed suddenly of an enormous load. If they were not promptly checked by an automatic governor immediately this happened they would "race" at a terrific speed, with grave consequences to the ship as well as to the engines.

As a rule, steam engines are fitted with centrifugal governors, generally of the Watt type. These consist essentially of heavy weights attached by short connecting links to a rotating shaft. If the speed of the engine increases the weights, under the influence of centrifugal force, tend to fly further away from the shafts and this movement is employed to partially close the steam admission valve. Owing to the smaller amount of steam admitted to the cylinders, the speed of the engine then drops until the weights resume their former position. A Meccano model of this type of governor is described under Standard Mechanism No. 87.

A disadvantage of the ordinary type of centrifugal governor is that its effect is not instantaneous. A sudden increase or decrease in the load may cause quite an appreciable fluctuation in the speed of the engine before the governor weights rise or fall, as the case may be, and so operate the throttle valve. To overcome this difficulty many devices have been invented from time to time, and perhaps one of the most ingenious and effective, as well as the most interesting for Meccano demonstration purposes, is the Siemens' Chronometric Governor.

This governor makes use of the differential principle, which was introduced by Sir William Siemens about the middle of last century, in conjunction with the conical pendulum.

The Meccano model illustrates the sensitive action of the governor in a clear and unmistakable manner. It is practically impossible to turn the operating handle with a sufficiently even torque to keep the valve counterweight at a constant height. The counterweight moves constantly up or down, registering the slightest fluctuation in the power imparted to the handle through the hand.

The best plan is to drive the model by means of a Meccano Electric Motor. For this purpose, a Pulley or Sprocket Wheel should be secured to the top of the vertical Rod, in place of the handle, and connected to the Motor by means of an endless cord or length of Sprocket Chain. A Meccano Resistance Controller should be connected in series with the Motor so that the speed of the latter may be varied as required. In this way the operation of the governor can be demonstrated in a very interesting manner. The slightest movement of the Controller switch arm will produce instantaneously a movement of the Crank 10, so indicating the change in the speed of the Motor.

### Construction of the Model

The operating handle 1 is secured to the top of a  $3\frac{1}{2}$ " Rod that is journalled in two  $5\frac{1}{2} \times \frac{1}{2}$ " Double Angle Strips bolted between the upright  $12\frac{1}{2}$ " Angle Girders. The  $\frac{7}{8}$ " Bevel Wheel 2 is secured near the lower end of this  $3\frac{1}{2}$ " Rod.

The Face Plate 3 is fastened to the lower end of a  $1\frac{1}{2}$ " Rod that is journalled in a third  $5\frac{1}{2} \times \frac{1}{2}$ " Double Angle Strip and in a Double Bent Strip, as shown, and a  $\frac{7}{8}$ " Bevel Wheel is secured near its upper end. The extreme ends of both the upper  $3\frac{1}{2}$ " Rod and lower  $1\frac{1}{2}$ " Rod are inserted in opposite ends of a Coupling, in the centre transverse hole of which is secured a 2" Rod carrying the  $\frac{7}{8}$ " Bevel Gear 4. The two first-mentioned rods are free to rotate in the ends of the Coupling and the Bevel 4 meshes with the two other Bevels. This mechanism resembles an ordinary epicyclic gear train. It may make the construction of the unit more clear if we refer readers to the differential gear in the new Meccano Motor Chassis (see Special Instruction Leaflet, or "M.M." for February, 1928) the construction of which is similar in many respects.

When the handle 1 is rotated the drive is transmitted via the Bevels 2 and 4 to the third Bevel on the vertical  $1\frac{1}{2}$ " Rod, and therefore the latter is driven in the reverse direction to that in which the handle 1 is turned. The Bevel 4 is quite free to rotate about its Rod, of course.

Fig. 120  
The Meccano Model of  
Siemens' Chronometric Governor

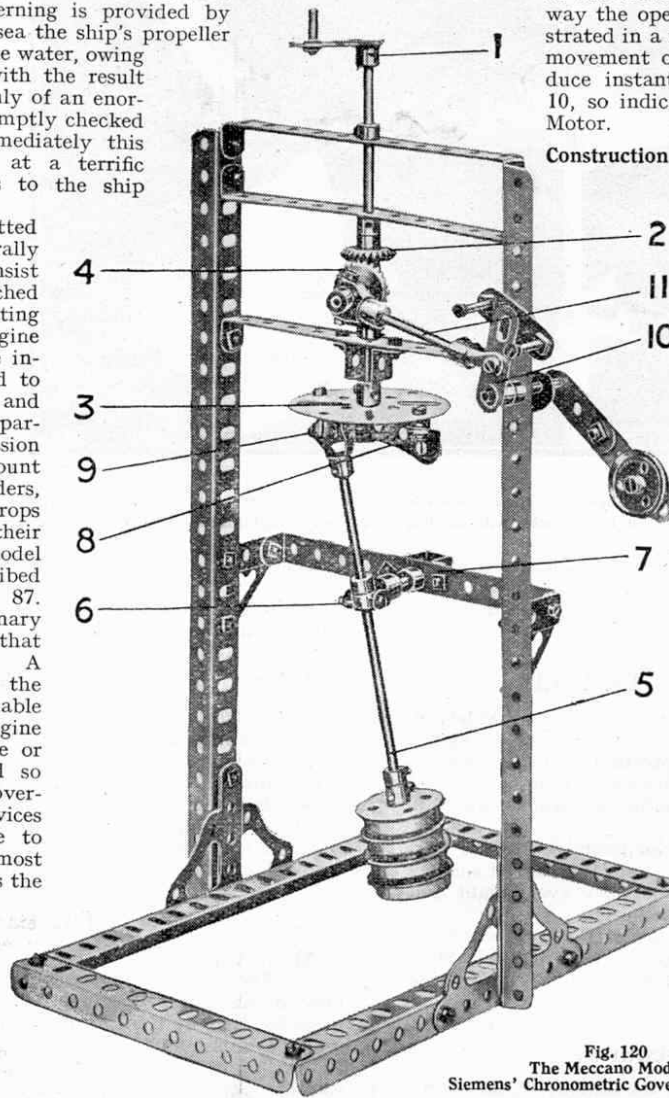

The conical pendulum 5 (so named because the area described by its swinging motion is of conical shape) consists of a 5" Rod weighted at its lower end with four Flanged Wheels and suspended by means of a ball-and-socket joint. The latter consists of an End Bearing 6 secured to a  $1\frac{1}{2}$ " Rod that is journalled in the  $5\frac{1}{2} \times \frac{1}{2}$ " Double Angle Strip 7 and also in a Double Bent Strip. The Rod 5 must rotate freely in the collar of the End Bearing 6. The

set-screws inserted in the collar are therefore provided with nuts that are locked against the sides of the collar to prevent the shanks of the screws touching the Rod 5. The latter is held in place in the Swivel Bearing by means of an ordinary collar and set screw.

The upper end of the pendulum carries another End Bearing 9 that is free to turn about a Pivot Bolt, the shank of which is gripped in the boss of an Eye Piece (new-style). The set-screws in this End Bearing should be locked in a similar manner to those of the Bearing 6 so that their shanks do not grip the Pivot Bolt. Two Washers are placed between the Swivel Bearing 9 and the boss of the Eye Piece. If an old-style Eye Piece is used at this point, the Pivot Bolt must be secured to it by means of two nuts, and the collar of the End Bearing 9 should be held in the required position on the shank of the bolt by means of additional Washers.

The Eye Piece slides on a 2 1/2" large radius Curved Strip 8, which is rigidly attached to the Face Plate 3 by means of two 1/2" x 1/4" Angle Brackets. The Brackets are secured to the Face Plate by 3/8" Bolts, and three Washers must be placed on each bolt for spacing purposes.

The Crank 10 is mounted on a spindle that in practice operates the throttle valve. It is connected to the 2" Rod carrying the Bevel 4 by means of another 2" Rod 11. The latter is attached pivotally to the Crank by means of a Small Fork Piece and its other end is attached to the 2" Rod of the Bevel 4 by a Swivel Bearing, the set-screws of which are provided with nuts so that its collar is perfectly free to turn about the 2" Rod between two Collars and set-screws. The movement of the Crank 10 is limited by stops in the form of two 3/4" Bolts secured to each end of a 1 1/2" Strip, and another Crank secured to its spindle carries a balance weight or counterpoise consisting of a 1" Pulley Wheel bolted to a 3" Strip.

A detailed description of the operation of the governor and the principles involved would necessarily be very lengthy. We must content ourselves therefore with a brief summary of the action of the model.

A certain amount of energy is required to maintain the pendulum 5 at a constant angle with the vertical, and it is a part of the contrivance artificially to increase the friction opposing the motion of the pendulum so that the pressure exerted by the counterpoise forms an actual measure of the maintaining force. Since the three Bevel Wheels form an epicyclic train, either the Bevel 2 and the lower Bevel fixed to the Rod of the Face Plate 3 must turn at the same rate, or Bevel 4 must run round the teeth of the lower Bevel. The latter is connected to the pendulum 5 and its rotation cannot be maintained without a constant expenditure of energy. Therefore the tendency of the lower Bevel is to lag behind the Bevel 2 and cause the Bevel 4 to travel round its teeth. But this movement of the Bevel 4 is checked by the counterpoise.

The governor is brought into action when the velocity of the engine is sufficient to keep the counterpoise raised slightly.

Because the lower Bevel is connected to a heavy revolving mass it can only change its velocity gradually, but the counterpoise is in equilibrium. Hence the slightest increase in velocity of Bevel 2 will be sufficient to raise the counterpoise further and so vary the steam valve opening.

(121)—Intermittent Switch

The device shown in Fig. 121 will start and stop an Electric Motor at certain pre-arranged intervals. It should be of great

Hornby Electric Railway, and the trains thereby started and stopped automatically at the stations.

The 57-teeth Gear 1 meshes with a Worm 3 that is driven from the Electric Motor via a suitable gear train. The constitution of the train depends entirely upon the results desired, since the periods of rest and motion are varied according to the rotational speed of the Gear 1. The 4 1/4" Rod 4 is mounted pivotally on a 2" Rod secured in the Bush Wheel 5, which is insulated from the base Plate by means of Insulating Bushes and Washers placed on the 6 B.A. Bolts that hold it in position. The terminal 6 is mounted on the shank of one of these bolts.

The contact piece consists of a 3/4" Bolt 8 mounted in a Threaded Crank. The latter is secured to a Corner Bracket that is insulated from the base Plate by means of 6 B.A. Bolts and Insulating Washers and Bushes. Normally the Rod 4 is held against the Bolt 8 by a tension Spring 9, which is anchored to the side plate of the Motor by an insulated 6 B.A. Bolt.

As the Gear 1 rotates, the Threaded Pin 2 secured in its face presses against the Rod 4, thus allowing current to flow from the terminal 6 along Rod 4, through the Gear 1, and back through the frame of the apparatus to the uninsulated terminal 7. When the Rod 4 comes to rest against the insulated stop 8, contact between the Rod and the Pin 2 is broken until the Pin, in moving round, again touches the Rod.

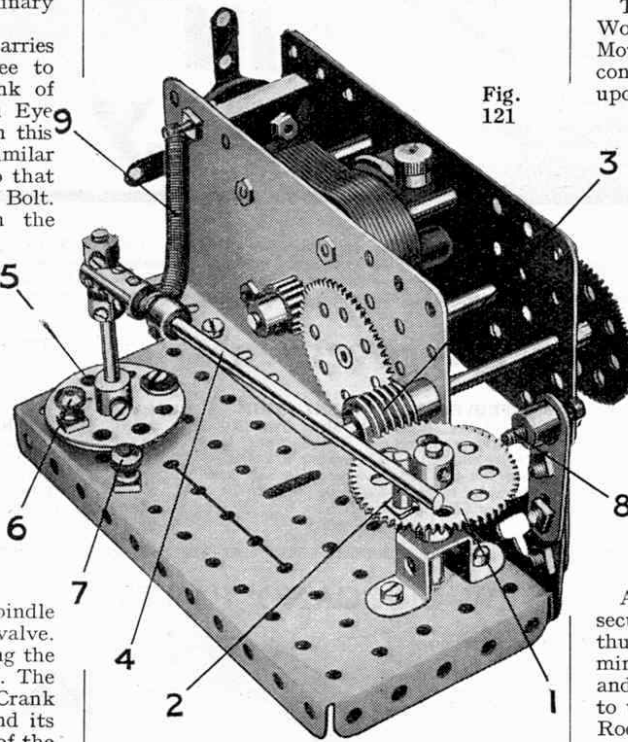

Fig. 121

value for window display models, or it may be incorporated in the circuit operating a

(122)—Meccano Spherometer

(G. A. Geach, Bridlington)

The Meccano Spherometer illustrated in Fig. 122 may be used for practical purposes. A spherometer is an instrument specially designed for ascertaining the degree of accuracy of curved surfaces. It can also be used as an ordinary micrometer for measuring plain surfaces.

a Face Plate on which is stuck a circular disc of white cardboard 3. A 1 1/2" x 1/2" Double Angle Strip 4 is bolted to the Flat Plate 1 close to the edge of the dial 3 and a strip of cardboard is pasted to it.

The instrument is calibrated as follows. Place a sheet of glass or other perfectly smooth surface beneath the instrument and rotate the Threaded Rod 2 so that it descends in the boss of the Threaded Crank until it lightly touches the glass. Draw a line on the vertical scale 4 on a level with the dial 3, and indicate the point on the edge of the dial 3 nearest to the scale 4. Now give the dial 3 one complete turn and draw another line on the vertical scale 4 level with its edge. On measuring the portion marked off on the vertical scale it will be found to be exactly 1/32", for the pitch of the Meccano Threaded Rod is 32 to the inch. The process should be repeated until the scale 4 is completed.

Next the dial 3 must be divided into sixty equal divisions. If the dial 3 is moved through one of these divisions, the Rod 2 will rise or descend through a sixtieth part of 1/32", i.e. 1/1920th of an inch.

When using the instrument, the article to be measured is placed beneath the Rod 2 and the dial rotated until the end of the Rod just touches the object that it is required to measure. The readings of the vertical scale 4 in 32nds and that of the dial 3 in 1920ths of an inch are then added together to obtain the desired measurements.

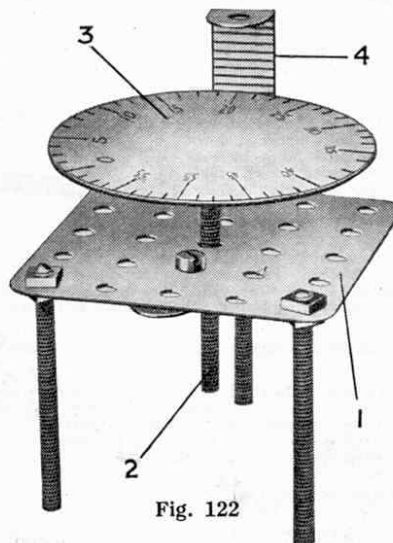

Fig. 122

The model consists of a 2 1/2" x 1/2" Flat Plate 1 supported on three legs composed of 2" Threaded Rods. Another 2" Threaded Rod 2 inserted in the tapped bore of a Threaded Crank carries on its upper end