

Fig. 3. An automatic reversing mechanism that can be applied to many different models. With its aid models such as transporter bridges can be operated continuously without attention.

reverse drive is obtained through a separate gear-box. This mechanism is shown in Figs. 3 and 4.

Many Meccano models can be adapted for continuous unattended working by including an automatic reversing device in the driving arrangements, and readers will therefore find wide scope for using the mechanism illustrated in Fig. 3 in their own models. For example, cranes can be made to carry out a definite sequence of movements, and the carriages of models such as transporter bridges and cooling plants, can be arranged to travel backwards and forwards, with a pause at each end of the travel for "loading" purposes.

The mechanism is housed in a framework across the centre of which two $2\frac{1}{2}'' \times \frac{1}{4}''$ Double Angle Strips 1 and 2 are bolted.

The input shaft 3 is fitted with a $\frac{1}{4}''$ Sprocket to take the drive from the Motor, and it carries at its other end a second $\frac{1}{4}''$ Sprocket 4. A Worm 5 is fixed on shaft 3 inside the housing. Sprocket 4 is linked by Chain to a $\frac{1}{4}''$ Sprocket fixed on Rod 6. This Rod carries a 1" Gear 7 and a $\frac{1}{2}''$ Pinion 8, and is held in position by Collars. A $\frac{1}{2}''$ Pinion 9 is free to turn on a $1\frac{1}{2}''$ Bolt fixed to the housing by two nuts.

A sliding shaft 10 carries inside the housing a $\frac{1}{4}''$ Pinion 11 and a 1" Gear 12, and outside the housing a $\frac{1}{2}''$ diameter, $\frac{3}{4}''$ face Pinion 13. Pinion 13 meshes with a 57-tooth Gear on the output shaft 14, which is mounted in 2" Strips bolted to the housing. Forward drive is obtained by sliding shaft 10 to the right, Fig. 3, so that Gears 7 and 12 engage. Reverse direction is provided by sliding shaft 10 to the left so that Pinions 8, 9 and 11 are in mesh.

Movement of shaft 10 is controlled by a $1\frac{1}{2}''$ Bolt 17 fixed in the centre hole of a $5\frac{1}{2}''$ Slotted Strip. The Bolt engages between the boss of Pinion 11 and a Collar fixed on shaft 10. The Slotted Strip is pivoted on a lock-nutted bolt attached to three 2" Strips 15.

A 57-tooth Gear 16 is fixed on a Rod mounted in Double Angle Strips 1 and 2, so that it is in mesh

with the Worm 5. The Gear 16 is fitted with a Threaded Pin that engages in the slot of the Slotted Strip.

The Pinion 11 and the Gear 12 should be adjusted on their shaft so that they just clear Pinion 9 and Gear 7 respectively when the Slotted Strip is in a vertical position. The Gear 16 is driven constantly by the Motor, and the Slotted Strip is therefore moved from side to side by the Threaded Pin engaging the slot. The Bolt 17 transfers this movement to the shaft 10.

The number of revolutions made in each direction by shaft 14 can be varied by altering the positions of Pinion 11 and Gear 12 on their shaft. To obtain an even drive the Pinion and Gear must be adjusted so that each remains in mesh for the same period.

SUMMER HOLIDAY SIMPLICITY COMPETITION

The special Holiday "Simplicity" Competition announced in last month's "M.M." is still open for entries in both the Home and the Overseas section, and we urge every reader who has not yet done so to send in an entry. The contest is for simplicity models of subjects associated with summer holiday activities and pastimes, and prizes will be awarded to model-builders who construct the most ingenious and attractive models using the smallest number of parts consistent with a realistic appearance.

Suitable subjects for the competition are to be found at almost every holiday centre, either at the seaside or in the country, while fairgrounds, with their many amusement machines, offer a very wide choice for displaying originality and novelty.

Competitors should send in either photographs or sketches of their models to "Summer Simplicity Contest, Meccano Ltd., Binns Road, Liverpool 13." The sender's age, name and address must be written clearly on each illustration submitted.

There will be separate sections for Home and Overseas readers, and the following prizes will be awarded in each section. First, Cheque for £3 3s. 0d. Second, Cheque for £2 2s. 0d. Third, Cheque for £1 1s. 0d. Five prizes of Postal Orders for 10/6 and five of Postal Orders for 5/-. The closing dates are, Home, 30th September; Overseas, 31st December.

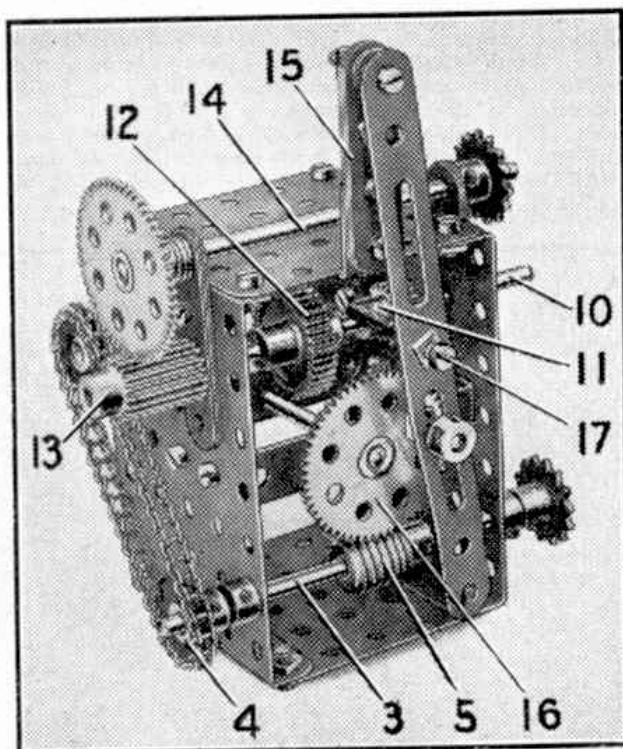

Fig. 4. An opposite view of the automatic reversing mechanism to that shown in Fig. 3.

Among the Model-Builders

By "Spanner"

A MECCANO DISPLAY BRIDGE

One of the collection of Meccano models to be seen at the Stand of Meccano Ltd., at the British Industries Fair in London this year, was the fine arch bridge illustrated on this page. This realistic model is roughly 5 feet in length and is very heavily built, the main bridge girders being compounded and solidly bolted together. The dignified design of the towers, built mainly from red enamelled parts, and the contrasting green of the sturdy arch itself, combined to present a very striking and realistic effect. At the B.I.F. the size of the bridge was emphasised by streams of Dinky Toys vehicles displayed on the roadway.

HOW TO USE MECCANO PARTS

Circular Strip (Part No. 145)

The Circular Strip is a very useful part. It is $7\frac{1}{4}$ " in diameter overall, and is a great help in the making of large circular structures, such as fly-wheels and in assembling built up roller bearings. In the latter it forms a means of supporting the rollers and is shown used in this way in Fig. 2. It will be seen from the illustration that the Circular Strip is in the form of a ring, and it carries four Double Brackets which provide bearings for $1\frac{1}{2}$ " Rods, each of which is fitted with a $\frac{1}{2}$ " Pulley. Each Pulley is spaced from its Double Bracket by four Washers, so that it runs between the rims of two Hub Discs. In a model such as a crane, one of the Hub Discs would be bolted rigidly to the top of the tower, and the other would be fixed to the underside of the jib.

It will be noticed that the Circular Strip has four slots cut in it in addition to the circular equidistant holes. These slots often are of great value

in allowing for the sideways adjustment of Strips, Brackets or other parts bolted to the Circular Strip in the assembly of various structures.

CORD DRIVING BELTS

R. Roberts, Birmingham, who is an enthusiastic builder of small models that he drives by means of belts made from Meccano Cord, says that he finds this method quite satisfactory if the tension of the belt is carefully adjusted, but that sometimes it is difficult to obtain just the right tension and the belt is apt to slip. Roberts says that he overcomes

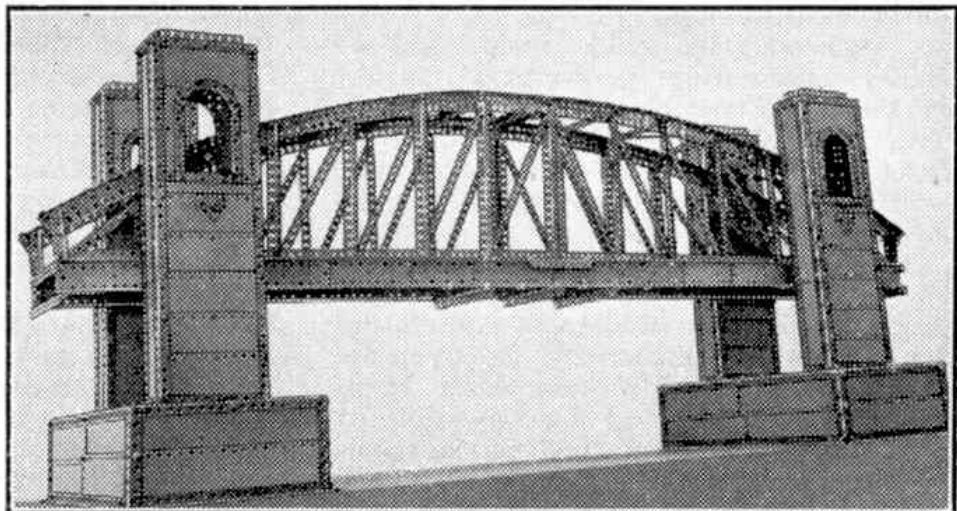

Fig. 1. This sturdy arch bridge was one of several large models exhibited at the British Industries Fair in London, last May.

this by rubbing the Cord with a piece of resin, or by powdering a little resin and then sprinkling it on the Cord after it is tied around the Pulleys, or in the case of hoisting Cords, attached to the winding drums.

In some cases where the belt does not have to make a complete revolution, as for example in hauling the trolley along the boom of a gantry or hammer-head crane, tension can be given to the Cord by tying its ends to the ends of a Tension Spring (part No. 43). The length of the endless belt made in this way should be such that when it is in position over the driving Pulleys the Spring is extended slightly. This arrangement will keep the belt in satisfactory tension and no slipping will occur.

AUTOMATIC REVERSING MECHANISM

In the May issue of the "M.M." I described an automatic reversing mechanism designed to operate the control lever of the E20R Electric Motor. This device was designed to reverse the drive by automatically changing the direction of rotation of the Motor armature, and it could therefore be used only with a reversible Motor. I have received since then enquiries from readers for details of an automatic mechanism that can be used with a non-reversing Motor, and this month I am glad to illustrate an efficient arrangement in which the

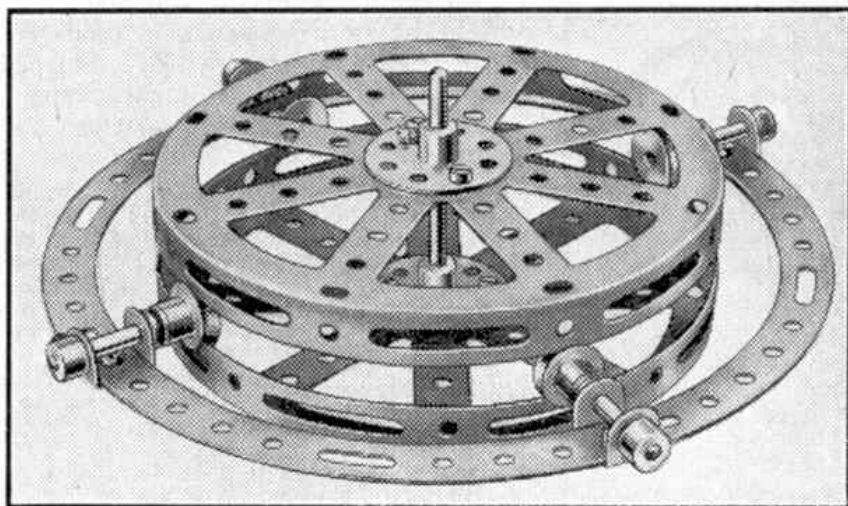

Fig. 2. Hub Discs and a Circular Strip form the main parts of this useful roller bearing.

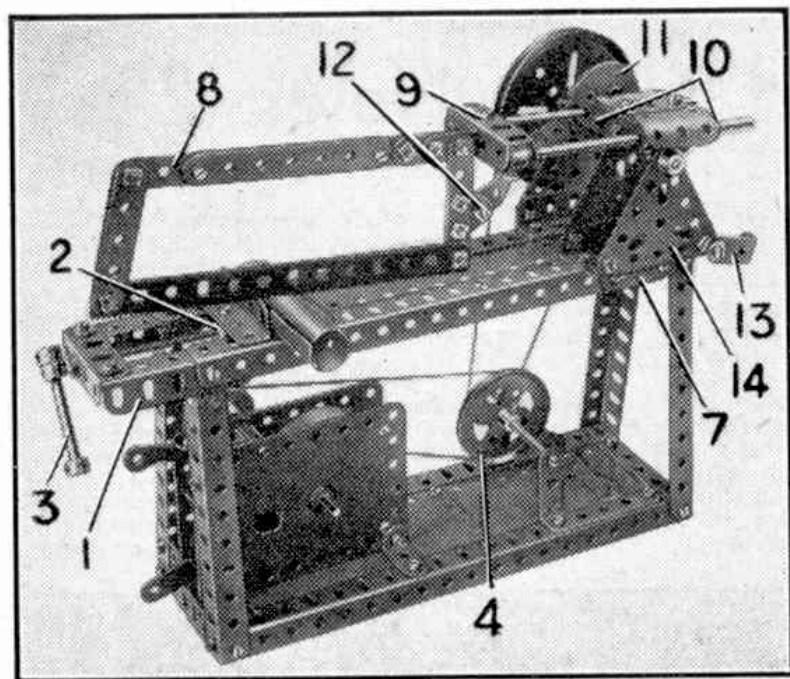

Fig. 3. A mechanical metal sawing machine driven by a No. 1 Clockwork Motor.

Sprocket Chain passed around a $\frac{3}{4}$ " Sprocket 9 on the same axle and the $\frac{3}{4}$ " Sprocket 10. The stand for the cycle consists of two Rod and Strip Connectors placed on each end of the axle, and each fitted with a 1" Rod that carries also two Collars. A Tension Spring is attached between one pair of Collars as shown.

Parts required to build model Motor Cycle: 2 of No. 3; 1 of No. 4; 4 of No. 5; 2 of No. 6; 6 of No. 6a; 22 of No. 10; 6 of No. 11; 2 of No. 12c; 3 of No. 16a; 2 of No. 17; 6 of No. 18a; 2 of No. 20a; 2 of No. 23; 2 of No. 24a; 2 of No. 35; 42 of No. 37; 32 of No. 37a; 18 of No. 38; 2 of No. 43; 5 of No. 48; 13 of No. 59; 4 of No. 63; 3 of No. 77; 3 of No. 80c; 1 of No. 94; 2 of No. 96a; 2 of No. 111a; 6 of No. 111c; 2 of No. 111d; 1 of No. 115; 5 of No. 126a; 2 of No. 142a; 1 of No. 163; 2 of No. 164; 2 of No. 176; 1 of No. 188; 1 of No. 189; 6 of No. 212; 4 of No. 215.

The model shown in Figs. 3 and 4 is a type of metal sawing machine used in raw material stores, tool rooms and machine shops for cutting through bar and strip metal. There are several types of these machines, and we have chosen one of the most popular as the basis for our model.

The base of the model consists of two $9\frac{1}{2}$ " Angle Girders, joined by two 3" Girders. The space between them is filled with two $5\frac{1}{2}$ " x $2\frac{1}{2}$ " Flexible Plates, and $5\frac{1}{2}$ " Angle Girders that form the table supports are bolted at each end. These are joined at the top by two $9\frac{1}{2}$ " Angle Girders, which are extended by $2\frac{1}{2}$ " Girders 1. The ends are connected by 2" Angle Girders. The table is formed by a $5\frac{1}{2}$ " x $1\frac{1}{2}$ " Flexible Plate.

The vice jaws are two 2" Angle Girders, one of which is bolted to the table. The other Angle Girder is attached to a Threaded Boss 2 carried on a 5" Screwed Rod. This Rod is mounted in an Angle Bracket bolted to the fixed 2" Angle Girder of the vice, and in the 2" Angle Girder at the end of the table. A 2" Rod 3 forms the handle, and is held loosely in a Collar locked on the end of the Screwed Rod.

A No. 1 Clockwork Motor is bolted in the position shown and fixed to the base and table supports by 1 " x 1 " and 1 " x $\frac{1}{2}$ " Angle Brackets. A 1" Pulley Wheel on the Motor shaft is connected by a 10" Driving Band to

a 2" Pulley 4, which is locked on a $2\frac{1}{2}$ " Rod mounted in two Flanged Brackets. This Rod carries also a 1" Pulley 5, from which the drive is taken to a 3" Pulley on a $3\frac{1}{2}$ " Rod 6. Bearings for this Rod are three $2\frac{1}{2}$ " Triangular Plates, two of which are attached to the table by $2\frac{1}{2}$ " Angle Girders. A third Triangular Plate 14 is secured by a $1\frac{1}{2}$ " Angle Girder 7 and a $2\frac{1}{2}$ " Angle Girder.

The saw blade is represented by a $6\frac{1}{2}$ " Rack Strip, which is bolted to a frame consisting of a $5\frac{1}{2}$ " Strip 8 and two $2\frac{1}{2}$ " Strips. Four $3\frac{1}{2}$ " Strips are also bolted to the $5\frac{1}{2}$ " Strip. A 2" Angle Girder 9 is attached to the frame by a 1 " x 1 " Angle Bracket, and two Cranks carrying 5" Rods are bolted to it. These Rods form slide rods and they slide in a guide made by connecting two 2" Strips 10 with $1\frac{1}{2}$ " x $\frac{1}{2}$ " Double Angle Strips. The guide block is covered by a $2\frac{1}{2}$ " x $1\frac{1}{2}$ " Flexible Plate bent to the required shape and attached by a $\frac{1}{2}$ " Bolt to an Angle Bracket fixed to a 1" Triangular Plate bolted to one of the 2" Strips 10. The guide is pivoted on Rod 6 by two Fishplates bolted to the $1\frac{1}{2}$ " x $\frac{1}{2}$ " Double Angle Strips.

The sawing movement is produced by the Triple Throw Eccentric 11. The arm of the Eccentric is extended by a $2\frac{1}{2}$ " Strip, which is lock-nutted to a 1" Triangular Plate 12 that is bolted to the frame of the saw. A 1 " x $\frac{1}{2}$ " Angle Bracket 13 attached to the $2\frac{1}{2}$ " Triangular Plate 14 by a lock-nutted $\frac{1}{2}$ " Bolt, forms a stop for holding the saw in a raised position when not in use.

A metal bar clamped in the vice is represented by two Sleeve Pieces.

Parts required to build Metal Sawing Machine: 1 of No. 2; 4 of No. 3; 1 of No. 4; 4 of No. 5; 3 of No. 6; 2 of No. 6a; 4 of No. 8a; 4 of No. 9; 2 of No. 9c; 5 of No. 9d; 5 of No. 9e; 1 of No. 9f; 2 of No. 10; 4 of No. 12; 2 of No. 12a; 2 of No. 12b; 2 of No. 15; 1 of No. 16; 1 of No. 16a; 1 of No. 17; 1 of No. 19b; 1 of No. 20a; 2 of No. 22; 72 of No. 37; 6 of No. 37a; 20 of No. 38; 2 of No. 48; 6 of No. 59; 2 of No. 62; 1 of No. 64; 3 of No. 76; 2 of No. 77; 1 of No. 80; 1 of No. 110a; 1 of No. 111; 1 of No. 111a; 2 of No. 111c; 1 of No. 130; 1 of No. 139; 1 of No. 139a; 1 of No. 186b; 2 of No. 188; 1 of No. 189; 2 of No. 192; 1 No. 1 Clockwork Motor.

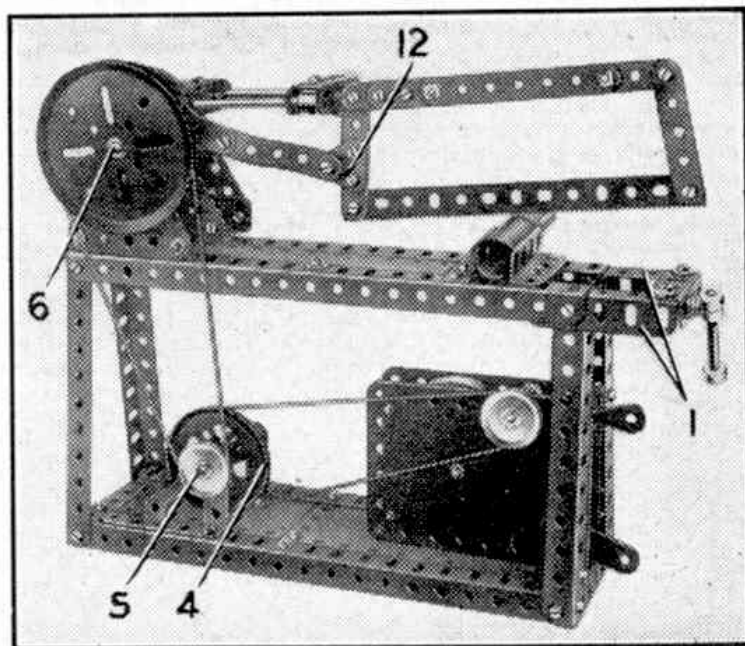

Fig. 4. Another view of the metal sawing machine.