

# A New Super-Model Mobile Crane

## Castor Steering and Electric Drive

MANY devices have been invented in an endeavour to solve the problem of high speed handling and transportation of materials and merchandise. One of the most popular and interesting of these is the mobile crane that forms the subject of the fine Meccano model shown in Fig. 1. The actual crane is entirely self-contained, with its own power unit, and combines the stability and efficiency of a stationary crane with extreme mobility. Its travel is not confined to a set of rails, or hindered by trailing cables from an external power supply, so that it can be used for transporting goods over a wide area.

The power unit in the model is an Electric Motor, and the luffing, hoisting and travelling operations can each be brought into play by the movement of levers within easy reach of the operator. The crane is slewed by rotation of a pivoted rear castor controlled from the operator's cab.

Construction of the model should be commenced by building the chassis. This consists of two channel

section girders 1, Fig. 2, formed from two  $9\frac{1}{2}$ " Angle Girders. These are bridged by two  $3\frac{1}{2}$ " Angle Girders, and are connected at their rear ends by a  $4\frac{1}{2}$ " Angle Girder, to which is bolted a  $4\frac{1}{2}$ " Flat Girder and two  $4\frac{1}{2}$ "  $\times$   $2\frac{1}{2}$ " Flat Plates 3.

The front axle 4 is journalled in Handrail Supports secured to built up semi-elliptic

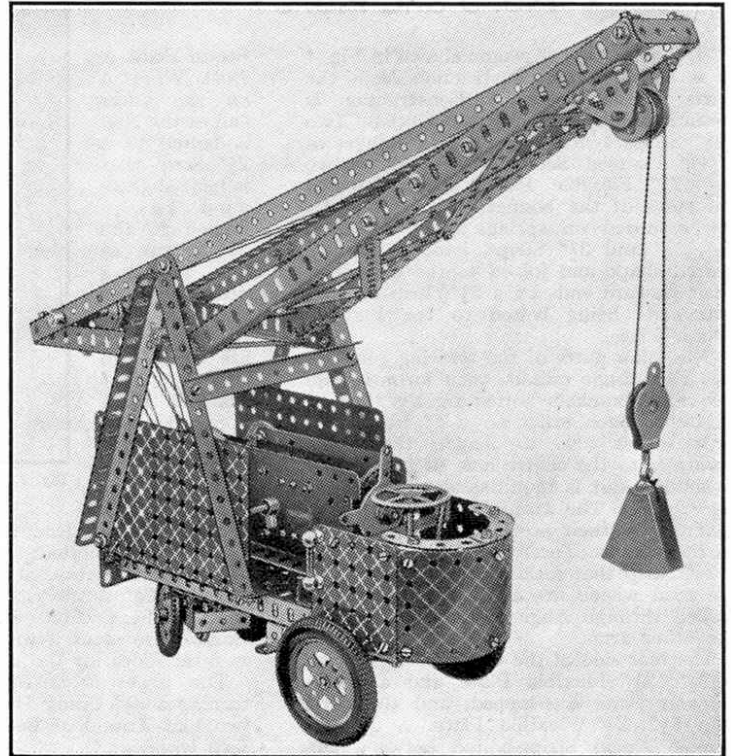

Fig. 1. A general view of the new Super Model Electric Mobile Crane.

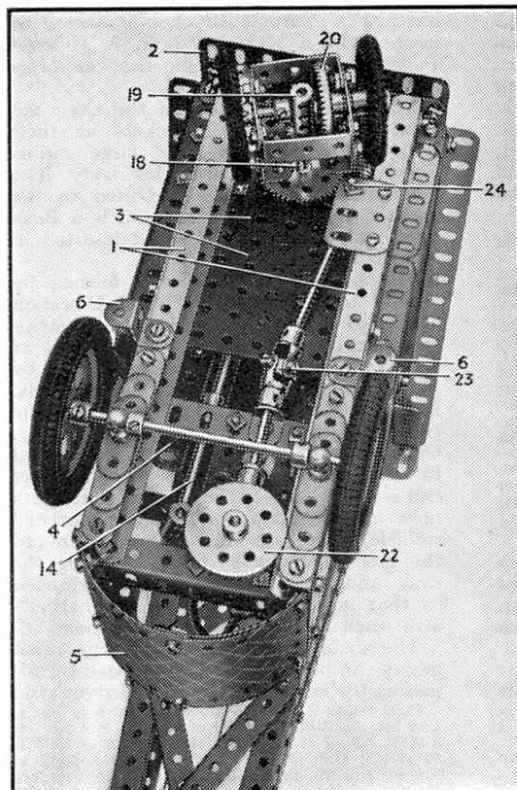

Fig. 2. An underneath view of the Electric Mobile Crane, showing the castor and steering mechanism.

springs attached to the chassis, and it carries two 2" Pulleys fitted with Tyres. The front of the driving cab is a  $4\frac{1}{2}$ "  $\times$   $2\frac{1}{2}$ " Flexible Plate bent as shown and attached to the ends of the girders 1 by two 3" Formed Slotted Strips. At its upper corners it is bolted to  $2\frac{1}{2}$ "  $\times$   $2\frac{1}{2}$ " Flat Plates fixed to the girders 1 by Obtuse Angle Brackets.

An E6 or E20B Electric Motor is attached to one of the  $3\frac{1}{2}$ " Angle Girders at the forward end of the chassis by  $\frac{1}{2}$ "  $\times$   $\frac{1}{2}$ " Angle Brackets, and its sideplates are extended by two  $2\frac{1}{2}$ "  $\times$   $2\frac{1}{2}$ " Flat Plates that are secured to them by two 1" Corner Brackets but are spaced from them by Washers. The  $2\frac{1}{2}$ "  $\times$   $2\frac{1}{2}$ " Flat Plates are bolted to two  $2\frac{1}{2}$ " Angle Girders fixed to the Flat Plates 3.

A Worm on the armature shaft of the Motor meshes with a  $\frac{1}{2}$ " Pinion 8 mounted on a 2" Rod that carries a  $\frac{7}{8}$ " Bevel Gear and a Collar. This Rod is journalled in a

Channel Bearing 9 bolted to one of the Motor sideplates. The Bevel drives a similar Bevel mounted on a  $2\frac{1}{2}$ " Rod that carries also a  $\frac{1}{2}$ " diam.  $\frac{1}{2}$ " face Pinion 10. The Pinion is in constant mesh with a 57-teeth Gear 11 on a  $2\frac{1}{2}$ " Rod, which also carries a  $\frac{3}{4}$ " Pinion 12, Fig. 4, and two Collars. This Rod forms the layshaft and can be moved sideways in its bearings by moving the control lever 13, Fig. 3. The latter is a 2" Rod inserted in a Coupling attached to one end of an 8" Rod 14, which carries at its rear end a Crank 15. A  $\frac{3}{8}$ " Bolt is fixed in the end hole of the Crank and its head engages between a Collar on the layshaft and the Pinion 12.

At this point it is advisable to assemble the automatic brake that maintains the load when the drive is transferred to operate the other movements of the crane. On the left-hand end of the layshaft is a Collar, and when the layshaft is moved the Collar pushes against the end of a 1" Rod that is fixed in a Coupling held on a 2" horizontal Rod 17. The 1" Rod is kept in close contact with the Collar on the layshaft by a short length of Spring

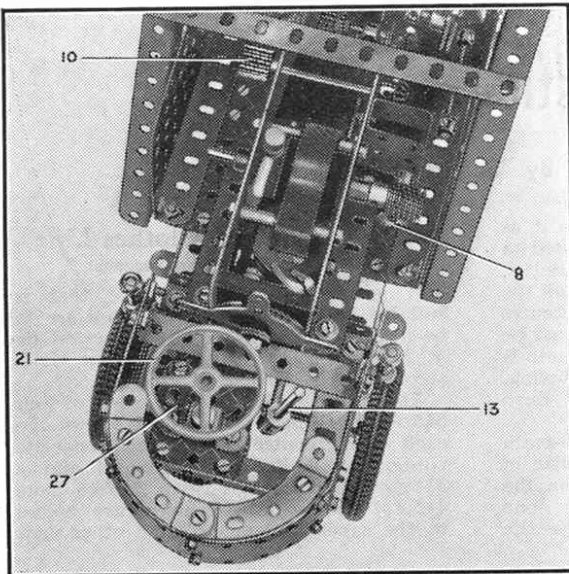

Fig. 3. The crane photographed from above to show the position of the Electric Motor and the control lever.

Cord. Rod 17 is journalled in a  $1\frac{1}{2} \times \frac{1}{2}$ " Double Angle Strip bolted to the chassis, and is retained loosely in place by Collars at each end. The brake band is a belt of Cord, which passes around a Bolt and around a 1" Pulley on a  $2\frac{1}{2}$ " Rod that carries also a 50-teeth Gear 16 and a Cord Anchoring Spring.

The castor unit and its gears are constructed as follows. Two  $1\frac{1}{2} \times \frac{1}{2}$ " Double Angle Strips and two  $1\frac{1}{2}$ " Flat Girders are bolted together to form a cage as shown in Fig. 2. Two  $1\frac{1}{2}$ " Angle Girders are then bolted to the Flat Girders, and they in turn are attached by means of two  $\frac{3}{4}$ " Bolts to a 57-teeth Gear mounted on a Rod 18. The Angle Girders are spaced from the Gear by the length of the Bolts. The lower end of Rod 18 is inserted in the longitudinal bore of a Coupling 19, which is mounted on a  $2\frac{1}{2}$ " Rod pushed through its centre transverse bore. Rod 18 carries also a  $\frac{1}{2}$ " Pinion that meshes with a  $1\frac{1}{2}$ " Contrate 20 on the Rod of Coupling 19. At its upper end Rod 18 carries a  $\frac{3}{4}$ " Contrate and is journalled in the Flat Plate of the chassis and a  $1\frac{1}{2} \times \frac{1}{2}$ " Double Angle Strip bolted above the Plate.

The castor is steered from the operator's cab. The Steering Wheel 21 is fixed on a  $3\frac{1}{2}$ " Rod journalled in a  $3 \times 1\frac{1}{2}$ " Flat Plate bolted to the chassis framework and in a Double Bent Strip bolted above the Plate. A  $1\frac{1}{2}$ " Bevel mounted on the lower end of this Rod meshes with a  $\frac{1}{2}$ " Bevel fixed on a 2" Rod journalled in  $\frac{1}{2} \times \frac{1}{2}$ " Angle Brackets, and is connected to a 4" Rod by a Universal Coupling 23. A Worm on the rear end of the 4" Rod meshes with the 57-teeth Gear of the castor unit,

and a bearing for this Rod is provided by a Handrail Support 24.

The Pinion 12 on the layshaft meshes with a 50-teeth Gear mounted on a 2" Rod 25 that carries also two Cord Anchoring Springs. A 2" Rod 26 carries two 1" Pulleys, over which the cord for raising and lowering the jib is passed, and also a Flat Bracket that is free to pivot and is held in place by Collars. The shaft 25 is controlled by a foot-brake that consists of a length of cord fastened at one end to the side of the gear-box, then passed around a 1" Pulley fixed on the Rod 25 and finally tied to a foot pedal 27 in the cab. This foot pedal is made up of a Flat Bracket bolted to the centre hole of a Double Bracket, which in turn is pivoted on a Double Bracket fixed to the floor of the cab. The brake cord is attached to the rear of the Flat Bracket.

Each side of the body is a  $5\frac{1}{2} \times 3\frac{1}{2}$ " Flat Plate bolted to  $5\frac{1}{2}$ " Angle Girders fixed to the girders 1. Two  $7\frac{1}{2}$ " Angle Girders are arranged to form an "A" frame, as shown, and at their upper ends are bolted to the end hole in the arm of a Crank.

The construction of the jib is quite simple and its details are clear from the illustrations. The jib head pulleys are mounted on a  $1\frac{1}{2}$ " Rod journalled in Trunnions A 5" Rod 28 journalled at the rear end of the jib carries four 1" loose Pulleys spaced from each other by Collars. Two Flat Brackets are placed on the Rod between the Collars and the outer Pulleys.

The cord for raising and lowering the load is fastened to a Cord Anchoring Spring on the Rod of

Gear 16 and then passed around the two centre Pulleys on the Rod 28, over the jib head Pulleys and around the Pulley of the Single Sheave Pulley Block. Finally the cord is tied to the Flat Bracket on the Rod 26.

Two equal lengths of cord for raising and lowering the jib are fastened at one of their ends to the Cord Anchoring Springs on the Rod 25, and are then passed around the outer 1" Pulleys on the Rod 28 and around the 1" Pulleys on the Rod 26. Their other ends are fastened to the Flat Bracket mounted on the Rod 28.

This completes the assembly of the model, but before it is set in operation it is advisable to oil the gearing and bearings, and to see that all the Rods run freely.

Parts required to build model electric crane:  
 4 of No. 2; 2 of No. 2a; 3 of No. 3; 3 of No. 5; 2 of No. 6a; 2 of No. 7a; 6 of No. 8a; 5 of No. 9; 2 of No. 9a; 2 of No. 9b; 2 of No. 9d; 1 of No. 9e; 2 of No. 9f; 4 of No. 10; 2 of No. 11; 8 of No. 12; 2 of No. 12c; 1 of No. 13a; 2 of No. 15; 1 of No. 15a; 1 of No. 15b; 1 of No. 16; 5 of No. 16a; 6 of No. 17; 1 of No. 18a; 3 of No. 18b; 2 of No. 20a; 2 of No. 21; 4 of No. 22; 6 of No. 22a; 1 of No. 25; 2 of No. 26; 1 of No. 26a; 2 of No. 27; 2 of No. 27a; 1 of No. 28; 1 of No. 29; 2 of No. 30; 1 of No. 30a; 1 of No. 30c; 2 of No. 32; 156 of No. 37af

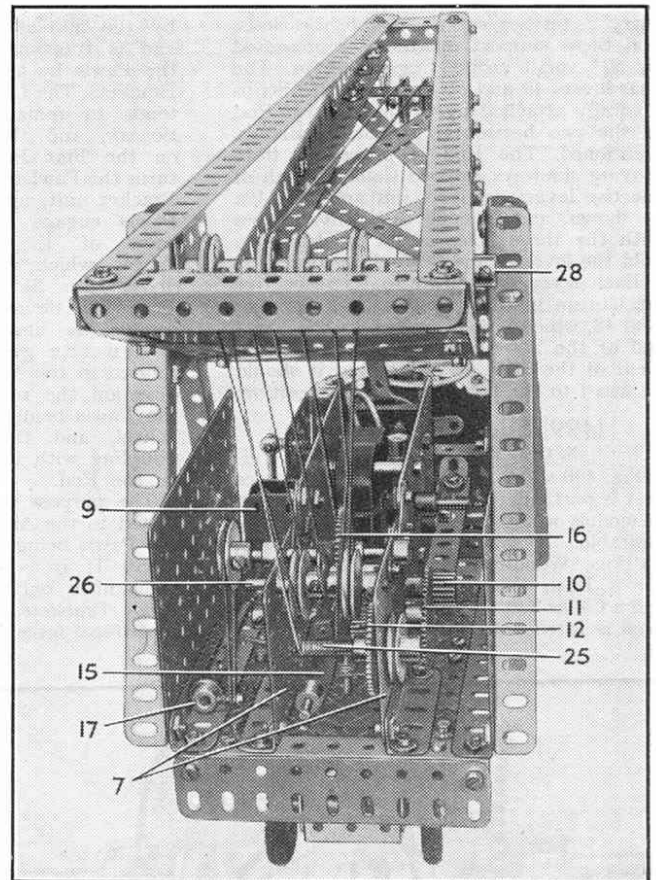

Fig. 4. The gearing and operating cords seen from the rear of the crane.

136 of No. 37bf; 63 of No. 38; 1 of No. 40; 1 of No. 45; 4 of No. 48; 1 of No. 48b; 2 of No. 52a; 2 of No. 53a; 3 of No. 58; 1 of No. 58b; 28 of No. 59; 3 of No. 62; 3 of No. 63; 4 of No. 72; 1 of No. 73; 1 of No. 82; 2 of No. 90a; 1 of No. 103c; 2 of No. 103f; 3 of No. 103h; 2 of No. 111; 4 of No. 111c; 2 of No. 125; 2 of No. 126; 2 of No. 133a; 7 of No. 136; 1 of No. 140; 2 of No. 142a; 2 of No. 142d; 1 of No. 151; 1 of No. 160; 3 of No. 176; 1 of No. 185; 1 of No. 191; 2 of No. 215.  
 1 E20B or E6 Electric Motor.

# Suggestions Section

By "Spanner"

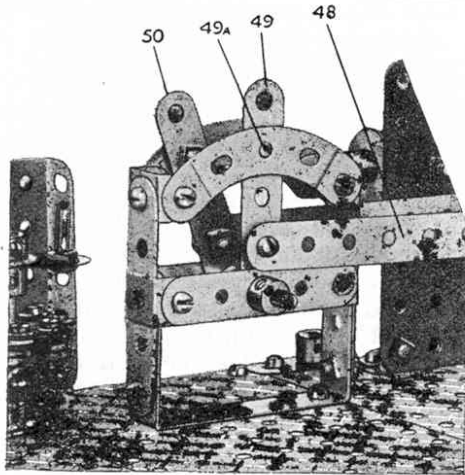

Fig. 498.

## (498) Twin Three-Position Levers

Fig. 498 shows a method of constructing and mounting levers intended for such purposes as gear changing, or the application of brakes in model cranes and excavators. A  $2\frac{1}{2} \times 1\frac{1}{2}$ " Double Angle Strip is bolted in any required position to the base of the model and each of its vertical lugs supports a  $2\frac{1}{2}$ " Strip. The centre holes of these Strips carry Double Brackets connected together by further  $2\frac{1}{2}$ " Strips.

The upper ends of the vertical Strips carry a further set of Double Brackets, and these support quadrants represented by  $2\frac{1}{2}$ " small radius Curved Strips. The gear levers 49 and 50 consist of  $2\frac{1}{2}$ " Strips pivotally attached by means of a  $1\frac{1}{2}$ " Rod to the two horizontal  $2\frac{1}{2}$ " Strips already mentioned. The Rod is prevented from moving sideways by two Collars. Each of the two levers carries a nut and bolt 49a as shown, and in each case this engages with the three holes of its quadrant, to hold the lever in any desired position.

Each lever is coupled to its respective mechanism in the gear-box by a Strip or Rod 48, which is lock-nutted to the lower end of the  $2\frac{1}{2}$ " Strip. If a greater movement of the Strip 48 is required it should be fitted to the lever in a higher position.

## (499) Silent Free Wheel

(N. C. Ta'Bois, Woodford Green)

Fig. 499 shows a novel free wheel device that is particularly useful for incorporation in models where quiet running is specially desirable. It was suggested by N. C. Ta'Bois, Woodford Green. A  $3\frac{1}{2}$ " Rod 1 has a Bush Wheel attached at one end and a Collar 2 at the other. A Pawl without Boss is fitted with a Flat Bracket and an

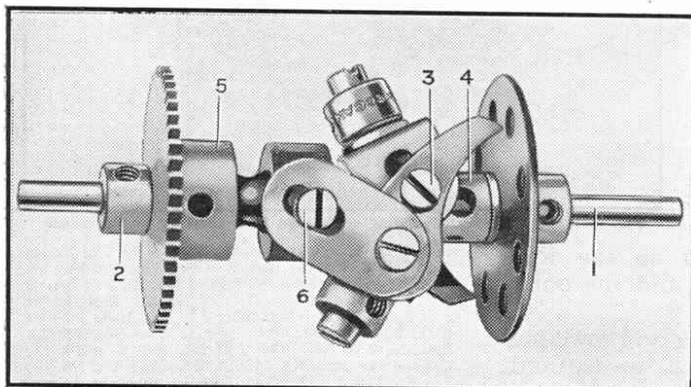

Fig. 499.

Angle Bracket, which are bolted to it as shown. A Collar and Washer are bolted to the Angle Bracket by a  $\frac{3}{8}$ " Bolt. The Bolt 3, which secures the Angle Bracket to the Pawl, is partly screwed into the centre tapped hole of a Coupling 4, and must be free to rotate slightly. A similar unit is attached to the other side of the Coupling. The Coupling is spaced from the Bush Wheel by one Washer.

A Socket Coupling 5 carries a 50-teeth Gear Wheel in one end and a Collar in the other. This Collar is spaced from the Coupling carrying the Pawls by one Washer. A Bolt 6 passes through the elongated hole of the Flat Bracket and carries a Nut that is locked against the Socket Coupling.

With the exception of the Bush Wheel and the Collar 2 the parts on the  $3\frac{1}{2}$ " Rod are free to rotate independently of the Rod.

The drive is taken up by the 50-teeth Gear and is transmitted to the Pawls by the Flat Brackets. The Coupling tends to remain stationary, and the pull on the Flat Brackets turns the Pawl and Flat Bracket unit, until the Pawls engage in the holes of the Bush Wheel, which in turn drives the  $3\frac{1}{2}$ " Rod. The whole device then rotates as one unit. When the gear is rotated in the opposite direction the reverse action takes place, the Pawls being retracted from the Bush Wheel, and the Socket Coupling and Coupling with their trappings rotate idly on the Rod.

The purpose of the Collar and Washer bolted to the Angle Bracket is to prevent the Pawls being disengaged by centrifugal force. If it is intended to rotate the mechanism only slowly the Collars and Angle Brackets may be discarded, as the centrifugal force exerted

on the Pawls will not be sufficient to raise them from the holes of the Bush Wheel until a fairly high speed is attained.

One great advantage of this free wheel over the usual Pawl and Ratchet type device is that it transmits the drive smoothly when in operation. Other useful features are its compactness and shape, which allow it to be incorporated in small models.

## (500) An Indoor Clothes Line

(J. Matthews, Aylesbeare Common)

A useful clothes line device that is suitable for use when light clothes are to be dried or aired indoors is suggested by J. Matthews, Aylesbeare Common. It is shown in Fig. 500.

The frame of the model consists of four  $3\frac{1}{2}$ " Angle Girders arranged as shown. To each of the centre holes of two opposite Girders are bolted a  $3\frac{1}{2}$ " Strip 1 and a  $4\frac{1}{2} \times \frac{1}{2}$ " Double Angle Strip 2. Two more  $4\frac{1}{2} \times \frac{1}{2}$ " Double Angle Strips are bolted to the same Girders, and the other ends

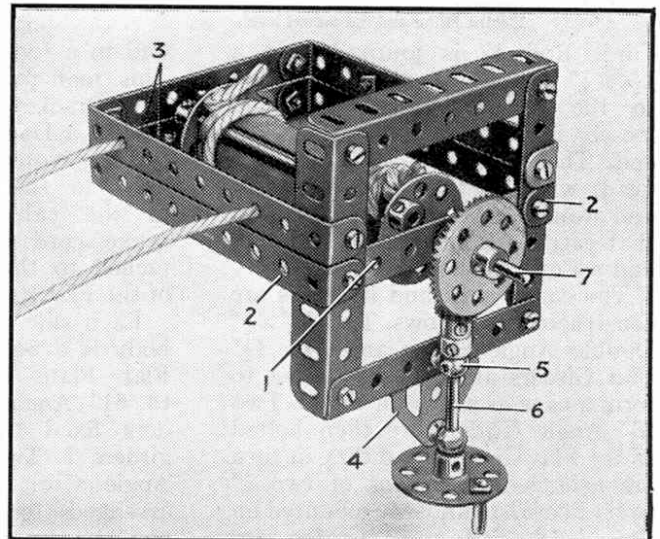

Fig. 500.

of the two pairs of Double Angle Strips are joined by two  $3\frac{1}{2}$ " Strips 3. A Trunnion 4 fitted with a Handrail Support is bolted to the lower  $3\frac{1}{2}$ " Angle Girders. The Handrail Supports provide bearings for a  $2\frac{3}{8}$ " Axle Rod 6 fitted with a Bush Wheel that carries a Threaded Pin and a  $\frac{1}{2}$ " Bevel Gear. The Bevel Gear meshes with a  $1\frac{1}{2}$ " Bevel Gear on a  $6\frac{1}{2}$ " Rod 7, which carries also a Wood Roller held between two Bush Wheels secured to the Rod.

The ends of the clothes line are gripped under a 5" Rod held by Collars in the groove of the Wood Roller. Outside the Bush Wheel on the rear end of the  $6\frac{1}{2}$ " Rod 7 is a Ratchet Wheel, and a Pawl attached to the frame by a Pivot Bolt prevents the cord from running out when the winding handle is released. The cord is attached to the drum so that one end of the cord unwinds as the other end winds up.

The indoor clothes-line should be firmly secured by the two  $3\frac{1}{2}$ " Strips 3 to a wall, in such a position that the winding handle is easily accessible.

If desired, the winding handle may be lengthened by using a longer Rod in place of the Rod 6, but it will be necessary to produce an additional support for this, as near as possible to the handle end. This may be a Handrail Support bolted to an Angle Girder attached to the frame.