

# THE MECCANO MOTOR CHASSIS

Full Instructions for Building this Interesting Model

PART II.

IN our issue last month we printed the first instalment of these instructions for building the Meccano Motor Chassis, which we consider to be a veritable triumph in Meccano model building. This model has been admired by His Majesty the King, and is in use in several schools of motoring for demonstration purposes. It shows in miniature the main mechanism

Fig. E. The main shaft drives through a pinion (27) engaging with a contrate wheel (26) which is bolted to a cage (23) mounted on the axle rods (16 and 17) which form the back axle. When the shaft (and consequently the pinion 27) rotates, the contrate wheel and cage (23) also rotate, the latter with its enclosed gear wheels (21) enabling either half of the back axle to rotate independently of the other half. Thus we may even hold the wheel at the end of axle (17), and with the finger spin the wheel on axle (16) either backwards or forwards. If the shaft and gear wheel (27) rotate, however, both rear wheels (mounted on axle 16 and 17) must do so also. Should the wheel on axle 16 revolve at a more rapid speed than the wheel on axle 17 or vice-versa, the difference in speed is taken up by the gear wheels (21) in the cage. Thus when the car is turning a corner or moving in a circle, the speed is adjusted by the differential.

found that the frame binds against the bosses of the contrate wheels, it may be pressed out to ease it.

The 1 1/2" pulley wheels (24) on the rod (16 and 17) are for the brake cords. 1" threaded rod (25) holds the frame (23) to the 1 1/2" contrate wheel (26) which takes the drive from the 1/2" pinion (27).

The outer frame (28) consists of a 3" x 1 1/2" bent strip, and the inner frame (23) is distanced by a collar (29) and the washer (30). The universal joint is made of two reversed double angle brackets (31) connected to the couplings by a 3/4" bolt with packing nuts (32) between.

The rear springs (33 Fig. B\*) are first connected to double bent strips (34) which are threaded on the rear axles and bolted to the side frame, the rear wheels being then secured to the axle.

Constructing the Gear Box

Now construct the gear box (Fig. F) beginning with the frame. The longer sides are composed of 4 1/2" strips bolted to 2 1/2" x 1" bent strips at each end. These are bolted on the 1" angle brackets (35) at each side.

On the 8" rod (36) a brake pulley (37) is fitted. Insert the rod (36) into the angle bracket (38) and fit on the two 3/4" pinions (39 and 39A) and the 50-toothed gear wheel (40).

The bevel pinion (41) takes the drive from the motor, engaging the bevel (41A Fig. B) and the 3/4" contrate wheel (42) is driven from the starting handle.

The clutch mechanism (43) is merely ornamental in this model, although an improvement is now in hand by which it actually functions. The bevels (41 and 41A) are driven by the sprocket (44) from the motor (see Figs. A\* and G). The 2" rods for the sprocket (44) and the bevel (41A) are mounted in the end holes of 1" angle brackets secured to one of the 5 1/2" cross strips.

\* Illustrated last month.

Fig. E. Differential Gear

of a modern motor-car, and its gear box and differential clearly illustrate the principles on which these mechanisms depend.

The Back-Axle Difficulty

To describe a differential gear on paper is a very difficult task, and it is very doubtful whether in this form even the most lucidly-compiled explanation leaves the motorist very much wiser. On the other hand, a model in Meccano shows exactly how this wonderful piece of mechanism functions.

Every Meccano boy knows that the differential is introduced in the back axle of motor-cars to allow for the difference in the speed of the outer wheel when the vehicle is turning a corner. As the outer wheel has to travel through a greater radius than the inner wheel, it is obviously impossible to use a solid back axle, as otherwise the difference in the speeds of the rear wheels would cause the axle to twist and snap. In the front wheels the difficulty is overcome by mounting them on stub axles, so that each revolves independently of the other. A similar method is adopted in four-wheeled carriages and lorries, but this practice is not possible in the case of motor cars, because the rear-wheels provide the tractive effort and must therefore be solidly coupled to the shaft that transmits the power from the engine.

An Ingenious Device

The difficulty is overcome in a very ingenious manner, as will be seen from

Building the Differential

The differential, which is shown in Fig. E as a complete unit, is built as follows:—

The 3 1/2" and 5" axle rods (16 and 17) are in two parts, which abut in and revolve freely in the coupling (18) and the contrate pinions (19 and 20) are nipped on with set screws. The 3/4" pinions (21) are nipped on 1" rods (22) for which the middle hole of the coupling forms a bearing. The frame (23) is made from two 1 1/2" x 1/2" bent strips and two 1 1/2" strips. If it is

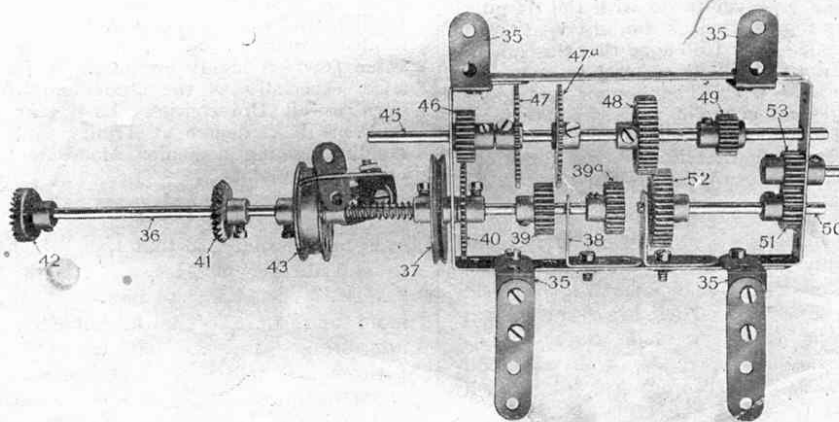

Fig. F. Gear Box

The Meccano Motor Chassis—(cont.)

The lay shaft (45) is then inserted, and the  $\frac{3}{4}$ " pinion (46), to 50-tooth gears (47 and 47A), 1" pinion (48) and  $\frac{1}{2}$ " pinion (49) are left loose on the shaft preparatory to the final adjustments. The driving shaft (50) is then inserted and its  $\frac{1}{2}$ " pinion

(51) and 1" gear (52) nipped on. A  $\frac{1}{2}$ " pinion (53) is pivoted on a 1" rod with collar and set screw. The coupling (31A Fig. E) is then connected to the projecting end of the shaft (50).

Changing Speed

By moving a lever (54) the shaft (45) slides and the changes of speed are controlled. When in top gear the pinion (46) engages the wheel (40) and the pinions (48 and 52) are engaged. For slow speed, the gear (47) engages the pinion (39) and the pinions (48 and 52) are still engaged. For reverse the gear (47A) engages the pinion (39A) and the pinions (49 and 53) are engaged, the latter driving the pinion (51) on the rear shaft (50).

A double bracket (56 Fig. D) is bolted to the side frame to act as a stop for the levers.

As shewn in Fig. G the motor is bolted at the front of the chassis on the  $5\frac{1}{2}$ " cross strips, and the 4 volt accumulator from lower cross strips (57) supported by triangular pieces (58).

THE END

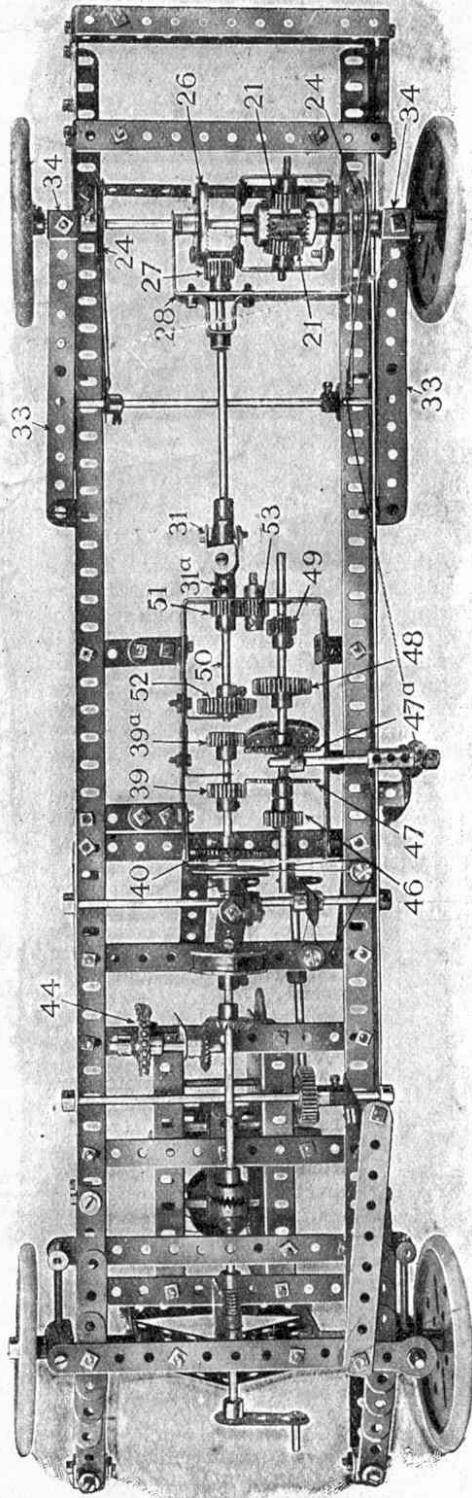
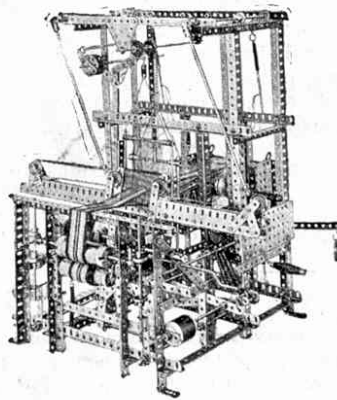

Fig. G.  
Under View of Chassis

## How to Build the Meccano Loom



The instructions recently given in the "M.M." for building the Meccano Loom have been reprinted as a leaflet. This is obtainable from all Meccano dealers, or from Meccano Ltd. (post free 4d.) The leaflet clearly describes the construction of this wonderful Meccano model, which weaves neck-ties, hatbands, etc., in a variety of artistic patterns.

## A New Meccano Clock

In our November issue we shall commence an article that describes very fully the construction of a Grandfather's Clock from Meccano. This clock, which stands 6 ft. in height, keeps accurate time and is a triumph of Meccano model building. The article will be fully illustrated, and in the same issue will be published a serial dealing with the fascinating story of clocks and other time-measuring devices. To prevent disappointment order your November "M.M." now if you have not already done so.

# OUR MAIL BAG



In this column the Editor replies to letters from his readers, from whom he is always pleased to hear. He receives hundreds of letters each day, but only those that deal with matters of general interest can be dealt with here. Correspondents will help the Editor if they will write neatly in ink and on one side of the paper only.

**H. Warne** (Manchester).—You are evidently not a very close reader of the "M.M.," Harry, or you would know that we have over a hundred and forty Meccano Clubs in this country.

**"Father of Boys"** (London).—Thank you for your suggestions, we shall endeavour to include articles of adventures and historical interest as space permits.

**N. O. Morden** (South Croydon).—Your lengthy criticisms are very helpful, and we shall bear them in mind for future reference.

**H. T. Bayliss** (Small Heath).—We are at all times pleased to consider contributions from Meccano boys, and we pay for those that are used. We are always pleased to consider articles, no matter what the subject may be.

**J. English** (Normanton).—We fear there are too many complications involved to allow us to start a Meccano boys' bank. We congratulate you on having saved so much money in five months. Thrift is very excellent, and there is undoubtedly truth in the old saying "Take care of the pence and the £'s will take care of themselves."

**W. O. Cantele** (Bristol).—Your suggestion is already in force; we pay 2/6d. for any photographs published in the Magazine.

**B. Baylis** (Port Erin).—Although a Christmas Annual would undoubtedly be a success, we fear it would not greatly help to improve the "M.M."

**J. Thornley** (Clifton).—We should very much like to print our illustrations in several colours, but unfortunately the expense of doing so is prohibitive.

**J. Blandford** (Cambridge).—We already provide a Magazine binder for holding the year's copies. This costs 3/- post free.

**P. Harvey** (Clapham).—We fear there are not many of our readers who would appreciate a column written in French. It would remind them too much of school, and the "M.M." is for brightening their leisure hours.

**T. E. Langdale** (Cloghan).—To print the names of all the members of the Guild would require hundreds of pages of the "M.M." We fear that the majority of our readers would be very disappointed if they opened their monthly copy to find nothing but names and addresses of Guild members in its pages!

**H. R. Wright** (Mansfield).—Your accident does not seem to have damped your spirits in any way, and we hope that by now your arm is alright again. We are sorry you could not call to see us when you came to Southport. The New Brighton Tower was taken down some time ago, owing to the cost of upkeep being so high.

**D. Horne, Jr.** (Kirkwall).—"I thank you very much for all your kindness. One would think that you are not an Editor at all, you are so human." All Editors are really human, David, especially those who, like myself, receive so many human letters from such splendid, sturdy boys. We shall be very glad to receive a photograph of your model of a warship.

**J. Chadwick** (Huddersfield).—We are very glad that you enjoyed your visit to Liverpool so much, and that your visit to our factory was such an outstanding feature of your holiday. We are always very glad to see any of our Meccano boys. A Meccano Magazine binder has been posted to you.

**D. M. Murdoch** (Ealing).—We have no space just yet for a puzzles column, but this may come later as we have had so many requests for it. We are glad you like the "M.M." so much.

**C. J. Bedford** (Leeds).—Many thanks for photo of your Meccano photo frame, which will be considered. The "M.M." will grow bigger and bigger, so just watch it.

**I. A. Young** (West Cholderton).—Photographs of any subjects which are of interest to other boys may be sent in and will be duly paid for if published. Thanks for your suggestion that we start a butterfly-collecting column, but we fear that this would not interest very many of our boys.

**D. Abel** (Allahabad, India).—Your drawings are quite good and you should persevere. We envy you with the lovely Indian winters of which you tell us. We may be able to start a puzzle column shortly.

**J. Miller** (Aberdeen).—"I met a chum to-day who asked me to give him one of my 12 $\frac{1}{2}$ " strips. "Then," he said, "I shall have as many as you." "No," I replied, "you give me one of yours then I can divide equally with your brother and we shall all have the same number as you." How many strips had each of us? Will somebody help us to solve this puzzle?

# MECCANO

## Examples of Model Construction:

### 1. MACHINE TOOLS

THERE is nothing more fascinating to every boy interested in engineering than the giant mechanical tools with which the world's great workshops and foundries are equipped. The daily work of some of these great machines would have employed hundreds of men a generation or so ago; their enormous strength has brought into existence the dynamo, steam engine, locomotive, and battleship.

It is interesting to surmise what our earliest ancestors would have thought of a man who could deliver blows of sufficient strength to forge a steel ingot into a liner's crankshaft; yet with a touch of the finger, the operator of a modern power hammer controls a force equal to fifty or sixty foot-tons!

We illustrate a selection of Meccano models, representative of this important branch of engineering. Meccano Machine Tools are not only miniature reproductions of the real thing; they may be worked like the real machines. By adding a fretsaw or hacksaw blade to the Sawing Machines, small pieces of wood may be cut through; similarly, by inserting a small twist-drill in the Drilling Machines, holes may be bored through strips of wood, and so on.

#### PRICES OF COMPLETE OUTFITS

|                                 |      |   |       |
|---------------------------------|------|---|-------|
| No. 000 ... ..                  | 2 6  | No. 5 (in superior enamelled cabinet with lock and key) ... | 100/- |
| No. 00 ... ..                   | 3 6  | No. 6 (in well-made carton) ...                             | 125/- |
| No. 0 ... ..                    | 5/-  | No. 6 (in superior enamelled cabinet with lock and key) ... | 155/- |
| No. 1 ... ..                    | 10/- | No. 7 (in superior enamelled cabinet with lock and key) ... | 450/- |
| No. 2 ... ..                    | 16/- |   |       |
| No. 3 ... ..                    | 27 6 |   |       |
| No. 4 ... ..                    | 52 6 |   |       |
| No. 5 (in well-made carton) ... | 70/- |   |       |

#### PRICES OF ACCESSORY OUTFITS

|                |      |  |       |
|----------------|------|--|-------|
| No. 00a ... .. | 1 6  | No. 5a (in well-made carton) ...                             | 55/-  |
| No. 0a ... ..  | 5 6  | No. 5a (with No. 6 Outfit cabinet) ...                       | 97/6  |
| No. 1a ... ..  | 7/-  | No. 6a (in superior enamelled cabinet with lock and key) ... | 235/- |
| No. 2a ... ..  | 12 6 |  |       |
| No. 3a ... ..  | 26/- |  |       |
| No. 4a ... ..  | 17 6 |  |       |

MECCANO LTD., Old Swan, LIVERPOOL

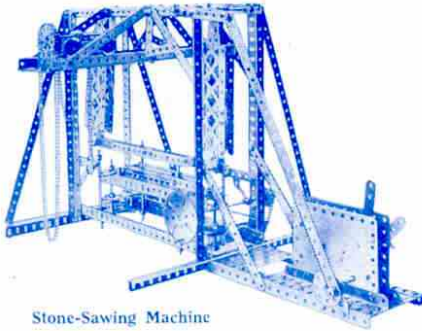

Stone-Sawing Machine

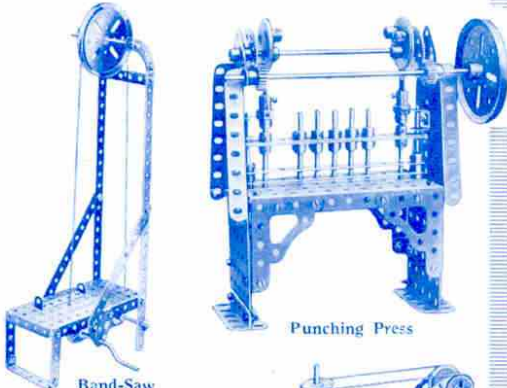

Band-Saw

Punching Press

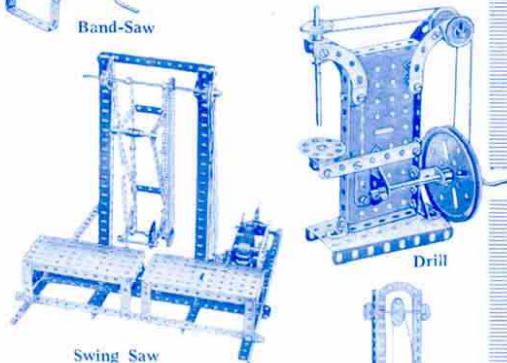

Swing Saw

Drill

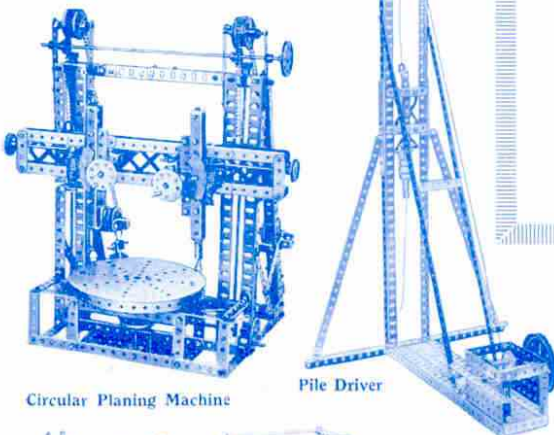

Circular Planing Machine

Pile Driver

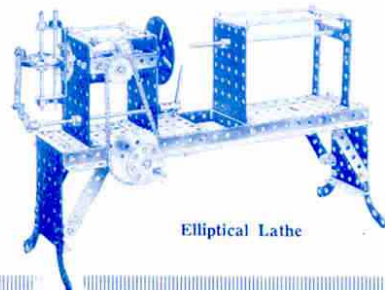

Elliptical Lathe

Drop Hammer

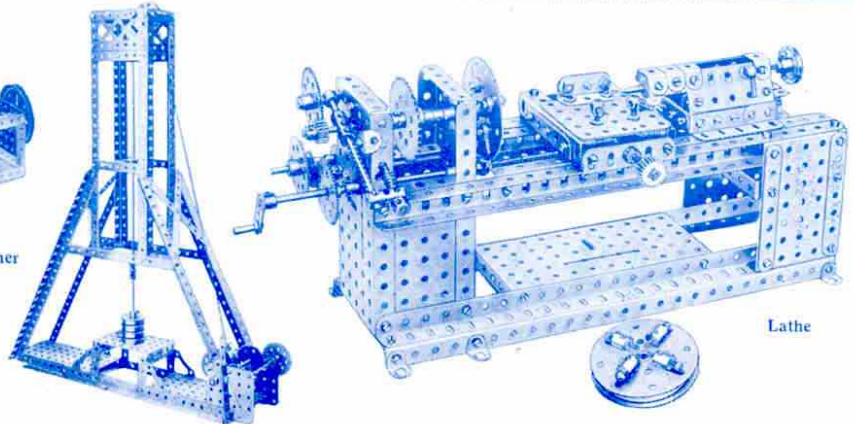

Lathe