

THE TAYLOR TOUCH

A COMMEMORATIVE ARTICLE
DEDICATED TO THE LATE
ERIC TAYLOR ■ BY BERT LOVE

At a time when the fortunes of Meccano Ltd were going through a sticky patch some ten years ago, a few adult enthusiasts exchanged letters with a view to injecting some new interest in the hobby. After a nervous start, when many an adult was wondering if he might be considered either childish or senile for getting out his long-cherished Meccano Outfit, the Midlands Meccano Guild was formed at Stratford-On-Avon, in 1968.

One of the founder members of this Guild was Eric Taylor of Nuneaton in Warwickshire, and I will never forget his breezy reply to my invitation to attend the inaugural meeting: "... be delighted to attend, ... quite handy with a broom, putting up tables etc ... I'll bring a model along, but it's nothing very special ..." Eric's 'nothing very special' model turned out to be the focus of the meeting, giving us all a lesson in how to build a model along engineering lines.

It was, of course, his well-known (now world wide) Giant Level-Luffing Crane. Its general outlines were taken from a thumbnail picture appearing on the cover of an old French magazine, but its construction was all Eric Taylor.

Before seeing the crane erected and operating, one enthusiast was foolish enough to remark in Eric's hearing that good supermodels could no longer be built because all the best parts were obsolete. When Eric put his crane through its paces, he soundly disproved such fallacies with his own model, making the case for obsolete parts so ridiculous that the unfortunate enthusiast concerned still has a red ear to this day!

Even a gentle wiggling for the use of the occasional non-standard part brought a ready reply from Eric, who would sketch an alternative section of the model using only standard parts, and anyone with the patience to test this, soon found that he knew what he was saying.

As a trained engineer, Eric could

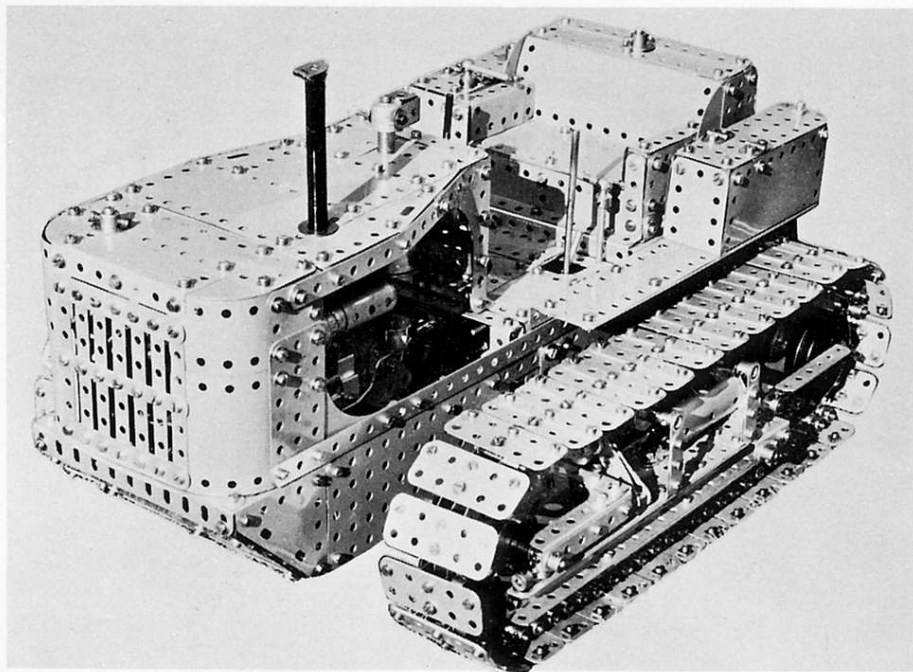

BELOW: An underside view of the late Eric Taylor's Giant Level-Luffing Crane. Elegant but sturdy portals supported the Crane on four power-driven floating bogies. All movements from the four independent motors were remotely controlled via a trailing 12-core cable.

ABOVE: A general view of Eric Taylor's Heavy Duty Crawler Tractor, in which all four gears were reversible, the tracks were spring-loaded for tension, and the track frames were compensated for chassis tilt by an ingenious equalizing beam mechanism.

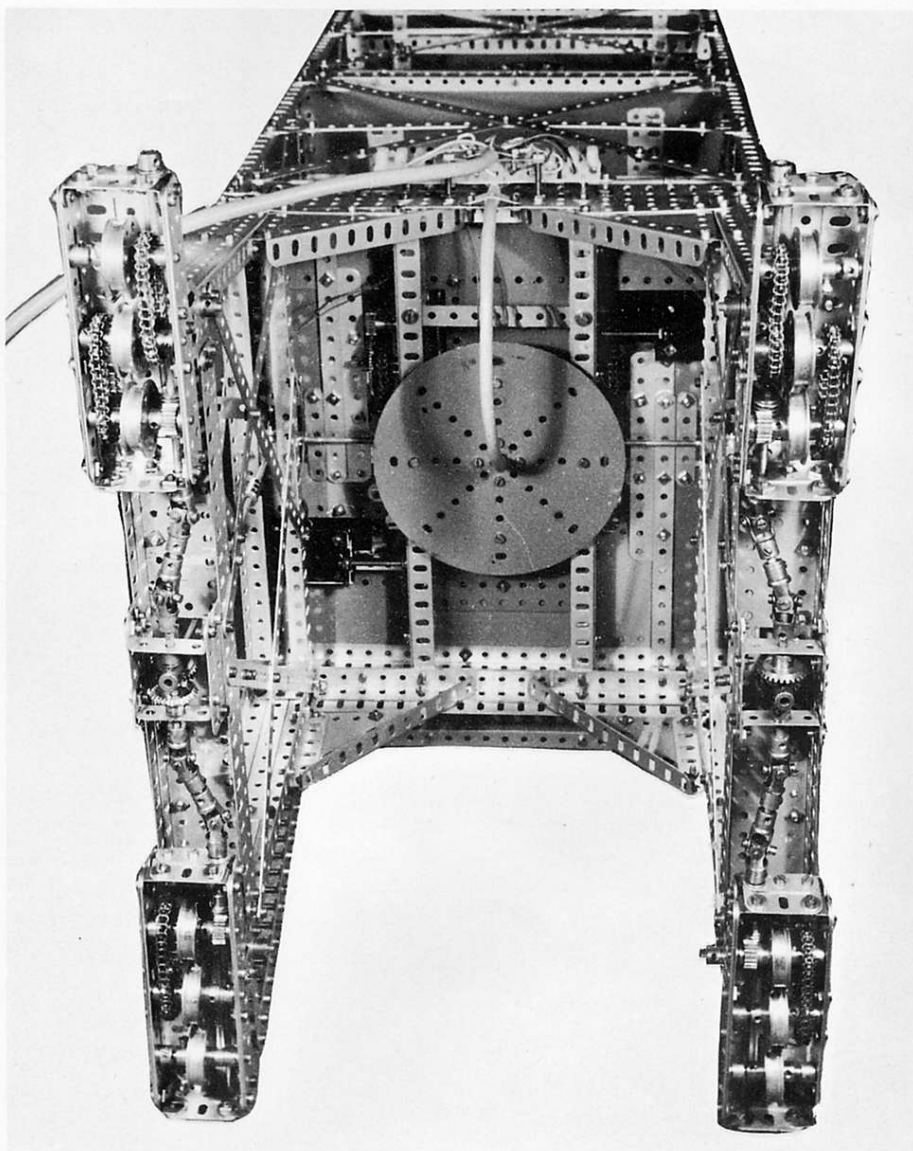

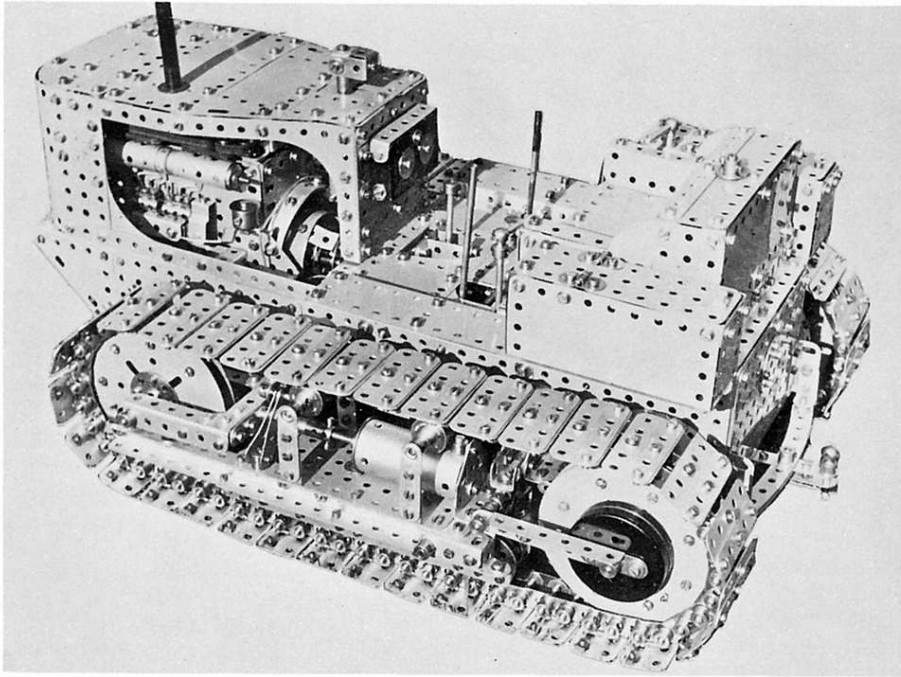

there, and what is more, those who thought that they knew a thing or two had to look to their laurels.

Those who had previously been entrenched in the notion that the pre-war Supermodels were the acme of perfection, had to revise their opinions pretty smartly. At the same time, other Guild members showed their mettle by producing very sophisticated models, and underlined the versatility of the system in so doing.

Any illusions that men were playing with children's toys were soon dispersed as the Guild increased its membership and broadened its range of modelling topics. Any enthusiast with a real eye for the possibilities of the Meccano system can see how far we have come just by a brief visit to Henley-on-Thames at Meccano Exhibition time, or to the country-wide exhibitions where the new traditions of superb Meccano modelling are clearly in evidence.

One good picture is worth a thousand words I am told, so I will continue my tribute to Eric Taylor by asking readers to take a close look at the four illustrations accompanying this article.

Eric's death is a sad loss to the Meccano Fraternity, but the recreation of his Crane, Tractor, and Giant Lorry-Mounted Crane at Meccano Meetings around the world is a great tribute to his example.

cope with anything from a model maker's specimen off the lathe to the control of a complete heavy earth-moving plant, so when he turned up with the equally well-known Heavy Duty Crawler Tractor at the next Guild meeting, it too was soundly designed on engineering principles.

His models reflected his personal philosophy of usefulness and purpose, ruggedness and reliability; he was not a man who suffered fools gladly.

It was a privilege for me to visit Eric's home, as I did quite frequently with my camera gear, to put his work on record stage by stage; and every challenge of mine as to why he had used a particular part, mechanism or method of construction was met with a precise and logical answer. As each model was stripped before the camera, a lifetime's skill was revealed in Eric's approach to his design and construction. The experience was something like sitting at the feet of Plato.

Building instructions for these first two models were drawn up by Eric and printed by the author in response to a wide demand, following the publishing of mere glimpses of the Crane and Tractor in the *Meccano Magazine*, and literally hundreds of copies of the original photographs were sent to Meccano enthusiasts in all corners of the globe.

The impact of Eric's models on the Meccano scene was almost electric. Model-building standards at subsequent meetings rose rapidly to a very high level. Some members stood back in awe, almost thunderstruck by the precision of this new-era Meccano modelling, but the inspiration for the fainthearted was

ABOVE: A side view of Eric Taylor's Heavy Duty Crawler Tractor showing rollers, sprockets and tension ram in the track frame. Some engine details can be seen, and the position of the gear, steering, and reverse levers. Note the swinging tow-bar pin and quadrant.

BELOW: A partial rear section of Eric Taylor's Giant Lorry Mounted Crane. Main and auxiliary gear boxes were fitted to the chassis. The machinery cab had self-erecting 'A'-frames, captive ball race, and anti-fouling luffing ropes. Additional features included tandem steering, brakes on all four wheels, twin rear differentials, on-beam coupled axles, and outrigger stabilizers.

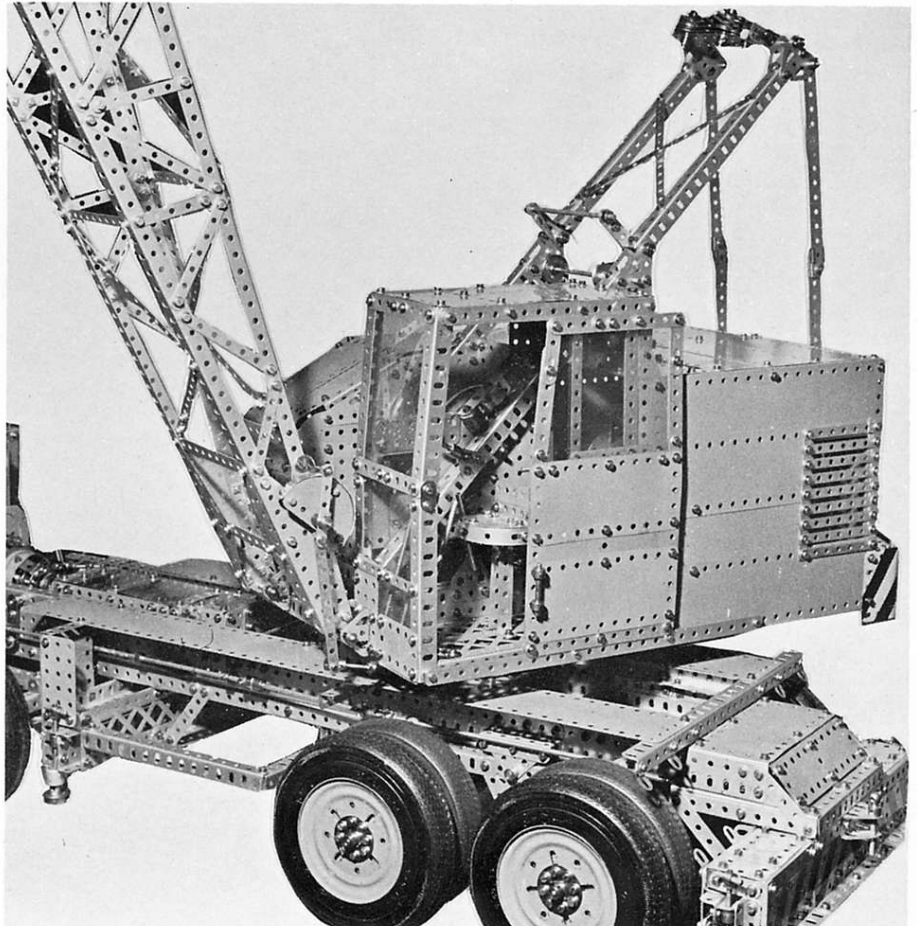

AMONG THE MODEL-BUILDERS with 'Spanner'



DRAWING ATTENTION

In 'Among The Model Builders' for this 'new look' MM, we have items ranging from a design for a simple sliding drive mechanism, to an electronic speed control for motors. First on the list this quarter, Niels Gottlob of Langs Hegnet 18, Kgs. Lyngby, Denmark, has written enclosing samples of his vast set of detailed, dimensioned, full-size drawings of Meccano parts.

Niels tells us that he has, over the past nine years or so, made over 400 drawings, and that a few are still to be made, due to the fact that he has not yet handled the original parts. The old Disc Weights and Dynameters, Collecting Shoe [Part 149], Shafting Standards, and several Lighting and Mechanised Army parts are among these drawings yet to come.

All the newer Clock Kit, Elekkit and Multikit parts are included, but Niels does not plan to draw Motor Car Constructor, Aeroplane, Elektron, Dinky Builder, Kemex, or Plastic Meccano parts, except insofar as they are used in conjunction with ordinary Meccano parts. Thus, parts such as the Aeroplane Collar and Pivot Bolt, Motor Car Constructor Collar (with cone), plastic parts from Multikits, etc, have been included.

The drawings are very fine indeed, and I am reproducing one here (reduced in size — the originals are 140x200mm), and Neils asks readers if they would like to acquire a complete set of (very good-quality) photocopies of his drawings.

Those interested should contact

him at the above address. If the demand is sufficient, it may be possible to produce the set of drawings as a book.

Anyone interested?

SPUR GEAR DIFFERENTIAL

The differential is a popular and useful subject for Meccano mechanism constructors, and has received a good deal of attention in these columns in the past.

John Mercer of Reading, England, has sent in a design for a heavy-duty spur differential. He writes:

"Modellers may have found that the differentials normally used with Meccano models either involve the use of Bevel Gears or Contrate Gears. Experience has taught me that Contrate Gears are apt to slip and become distorted very easily; they tend to wear the Pinions rather quickly. In real engineering, the practice of using Contrate Gears is never seen, and for this reason, we often use Bevel Gears in differentials. However, I find that after I have built most of the model and I come to build a differential, I have no Bevel Gears left. To buy more is, as we are all aware, quite expensive, so I have designed a differential using only spur Gears.

"This has the advantage that it can be built with more common Meccano parts, and that it can be more rigidly made than can the Contrate-style differential. It can also handle heavier loads without distortion of the frame, which is what always seems to happen to mechanism N: 20 from the Meccano Mechanisms Set.

"The diagram shows how the

Gears are used. A and B represent the frame to hold the mechanism. This may take any form the constructor wishes, and can be as strong as necessary, as it does not rotate as do the main-frames of other differentials.

"Once the frame has been constructed, put one Collar and a Washer onto a 3 1/2" Rod, pass this through the frame and slide on three Washers, followed by a Gear Wheel [27a, 27b, or 27c — depending on the speed of rotation required for the rear axle]. This Gear is free on the Rod. After this, put another Washer and a 1/2" Pinion on the Rod.

"Repeat this procedure at the other side of the frame, but using an 8-Hole Bush Wheel instead of the large Gear. Once this has been set up, take two 3" Rods, each holding three Collars, four Washers, a 1/2" Pinion, and a 1" Gear Wheel, as shown in the diagram. This should turn freely. Repeat the procedure in the other direction with the other Rod.

"The Rods are mounted in opposite holes of the Gear and Bush Wheel.

"All Gears are fixed on the Rods, except 27a (b or c) and the Bush Wheel. The drive is taken to the Gear just mentioned via a Worm or Pinion. The differential is now useable.

"If you find that the system is not rigid enough, it is easy to double the Bush Wheel and the large Gear so that the 3" Rods have more positive support, but I will leave it to the modeller to adapt the idea as necessary."

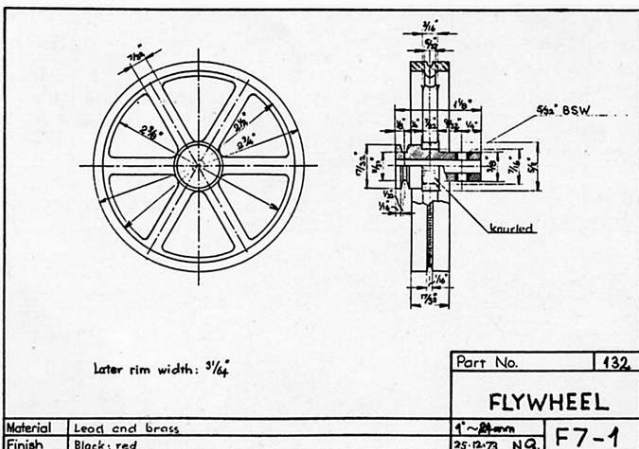

LEFT: One of Niels Gottlob's drawings of Meccano parts — see first item above.

BELOW: The Spur Gear Differential described on this page

SLIDING DRIVE MECHANISM

Mike Cotterill of Skegness, has written briefly with details of a mechanism that he has designed to transfer a drive to a sliding shaft in line

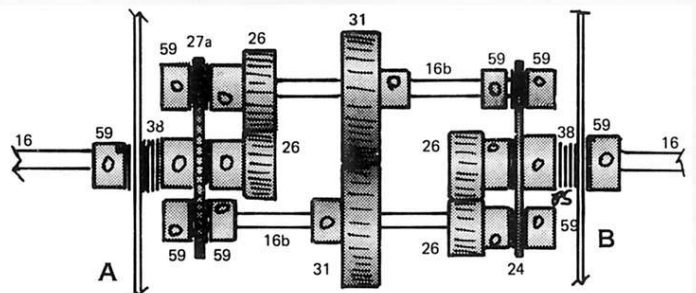

with the driving shaft.

He says: "This is often done with two pins on two ordinary Bush Wheels. This gives problems if:

- 1] any shafts are bent.
- 2] the pins are not exactly parallel.

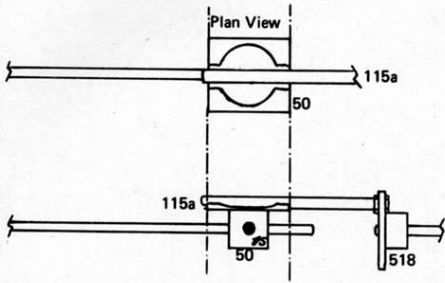

- 3] either Bush Wheel does not run true, under which circumstances, the sliding shaft is often unable to slide fully.

"One disadvantage of the alternative design shown in the diagram is that some slack is present; this is, however, only important if the shafts have to reverse frequently or precisely."

SIDERIAL TIME MECHANISM

Think of Meccano clocks, and the chances are that the name of Pat Briggs of Wollaton, England will spring to mind. Always a cornucopia of Meccano clocks and their mechanisms, Pat can be relied upon at all times to come up with something new.

Pat has sent us the details of a Siderial (Star Time) Mechanism, which contains the means of building up sprocket wheels to your own specification. He writes:

"A simple means of obtaining siderial (or star) time is achieved by speeding up mean solar time by the ratio $366/365$; this will be accurate to within 57 seconds per year.

" $366/365$ will factorize to give the simple gear train $61/73 \times 60/50$, and 50-tooth, 60-tooth, and 73-tooth are all available in the system (the latter will be recognized as the Toothed Disc of the Ball Thrust Race [Part 168]). But how do we get 61 teeth?"

"This problem can be solved by building up a wheel-plate on which are bolted six $3/4$ " Sprocket Wheels. A loop of Chain with 61 links is used to set the Sprockets at the correct distance and radial position to ensure a smooth mesh with the Chain.

"At intermediate positions between the Sprockets are positioned Threaded Pins or $1/2$ " Bolts, so that the made-up unit has a near-circular form. The Chain loop is then removed, leaving us with an effective 61-tooth sprocket.

"In this way, wheels can be built up with tooth numbers over a wide range.

"It is conceded that the drive will be slightly cyclic, and a 'jockey' will be needed to deal with the varying Chain slack."

BATTERY BOX VOLTAGES

Mrs (Granny) Bakker of Holland, has written concerning the internal connexions of the (original 12/4.5v) Meccano Battery Box. She writes:

"Happy circumstances made me the owner of a voltmeter, and at that moment I remember something that had been 'Rounded-Up' in *JME 6* of December 1974, regarding the possibilities of the Battery Box contained in the outfit of many a one.

"To my surprise, the Battery Box gave 4.5v reverse in this position: $\leftarrow \leftarrow$, and not in the $\rightarrow \rightarrow$ position, where I got no current, a 'stop position'.

Playing with my voltmeter, I concluded that the scheme of the Box could be:

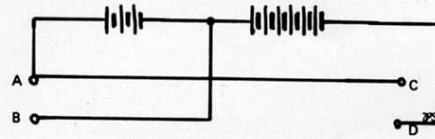

Then I used the other two sockets (left under and right up):

- | | | |
|-----------|---------------------------|--------------|
| Switches: | $\leftarrow \rightarrow$ | 12v |
| | $\rightarrow \rightarrow$ | 9v |
| | $\rightarrow \leftarrow$ | 4.5v reverse |
| | $\leftarrow \leftarrow$ | no current. |

Using the upper sockets:

- | | | |
|-----------|---------------------------|--------------|
| Switches: | $\rightarrow \rightarrow$ | 12v |
| | $\leftarrow \rightarrow$ | 9v |
| | $\leftarrow \leftarrow$ | 4.5v reverse |
| | $\rightarrow \leftarrow$ | no current |

Using the lower sockets:

- | | | |
|-----------|---------------------------|--------------|
| Switches: | $\leftarrow \leftarrow$ | 12v |
| | $\rightarrow \leftarrow$ | 9v |
| | $\rightarrow \rightarrow$ | 4.5v reverse |
| | $\leftarrow \rightarrow$ | no current. |

It's true: with Meccano, everything is possible!"

YELLOW PAINT

Michael Edwards of Watford, England, has written to tell us of a paint suitable for retouching Meccano yellow-painted parts. The paint is Humbrol MC2 - Yellow Fairings, and should be available from any good model shop.

The paint is a matt finish, and as such, will need a subsequent coat of varnish.

Michael enclosed a sample of the paint with his letter, and I can

affirm that it is a good match for some yellow parts, but slightly too light for others, due to the variations of hue between paint runs at the Factory.

For more information on paints for retouching Meccano parts, see: *JME 5* 1974 September, and *ME 9* 1975 September.

ELECTRONIC MOTOR CONTROL

Dr Keith W Cameron of Ary, Kentucky, USA, writes to say that he has just built up a simple electronic gadget, familiar to most model railway fans, but possibly not so well-known to Meccanomen, to whom it may be of use. The device is a motor speed control with built-in starting, coasting and braking effects, all automatic, and easily built from two transistors, three resistors, a potentiometer, and a capacitor.

The device uses a resistance-capacitor time delay, which is applied to the base of a small general-purpose transistor, coupled to an output power transistor in cascade.

Those who use this unit to control trains and the like will have no problem fiddling with the control knob on hills either up or down; and, on shutting off the 'throttle', the engine will come to a realistic, gradual halt, for all the world as if it were 'free-wheeling'. The basic circuit can be built on a small piece of perforated circuit board 50mm x 25mm, the heat sink for the power transistor can be mounted on one flange of a $3\frac{1}{2} \times 2\frac{1}{2}$ " Flanged Plate, with the control mounted in a small piece of formica on the other flange.

The circuit diagram is as shown. The power transistor must be mounted on as heat sink. Keith

COMPONENTS REQUIRED:

- C1 2000 μ f 25v electrolytic capacitor.
- C2 150 μ f 15v electrolytic capacitor.
- D1-D4 Silicon rectifiers - can be full-wave bridge rectifier.
- F $1/2$ -amp Fuse.
- Q1 p-n-p Transistor, small signal, 2N137D or equivalent.
- Q2 p-n-p power Transistor, HEP200, or equivalent.
- R1 1000 Ω 1W Linear potentiometer
- R2 33K Resistor.
- R3 100 Ω Resistor.
- R4 1K Resistor.
- S1 On/off Switch.
- S2 SPST (Single pole - single throw) press on/release off Switch.
- S3 DPDT (Double pole - double throw) reversing switch.
- X Insert a high-current automobile bulb here, and you have a short-circuit-proof overload protection device.

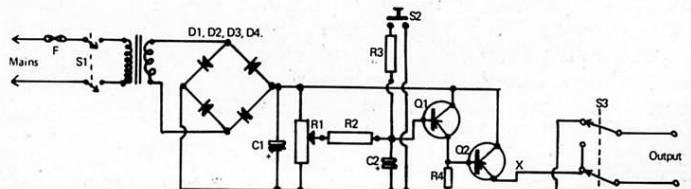

RIGHT: Dr Keith W Cameron's electronic motor-control circuit.

mounted two, one n-p-n, and the other p-n-p, insulated from the sink, but with heat sink compound added. In this way, he has two circuits, and the ability to use them back-to-back for easy reversing.

Closing S2 defeats the 'free-wheel' effect and has the effect of an emergency brake. The circuit will not give accurate 'spot control' for cranes and similar models, but for operating Meccano locos and other moving vehicles, it has intriguing possibilities.

A CURE FOR BENT RODS, STEERING WHEEL WHEELS, & SHOWMAN'S ENGINE DYNAMO

Next this quarter, Brian Rowe of Newton Abbot, England, has written on several Meccano subjects. He writes:

"I have managed to get round some of the problems of bent Axles (only those over 3½" in length). The necessary requirements are a 5½"X2½" Flanged Plate and a small hammer.

"For the shorter lengths, place the Axles in the 2½" width of the upturned Flanged Plate and rotate with the fingers. You will soon notice where the bows and bends are, and a few light taps with the hammer will straighten them. Use the hammer on the 'high' parts, and do it carefully.

"Similarly, the longer Rods can be placed in the 5½" upturned flanges and treated in the same way. Where the ends of the Axles are contorted, it is a better idea to place each offending Rod on a flat piece of metal, rotate, and gently tap the ends of the Rod."

On Steering Wheels [Parts 185 & 185a]:

"By bending up the tabs on the coverplates and removing the covers, you have the means of making an 8-spoked front wheel for a small Traction Engine. Use two wheels butted together with the spokes offset. This is a good scale for the use of Spoked Wheels [Part 19a] as rear wheels (again, two butted together with spokes offset).

"A rubber tread enhances the effect, and is easily fitted over the twin rims. The 2½" Steering Wheel gives a 6-spoke layout as above, but rear wheels are difficult to fit to this scale (3" Curved Strips are about the nearest for rear wheels).

"I am in the process of designing a Showman's Engine dynamo, built around the new Meccano 4.5v Crane Motor (as suggested on p21 of ME11), and it is hoped that this will provide the power for the engine (with Hub Disc rear wheels) as a whole. The 2" Strip with centre hole will be most useful in this respect, as I intend to use Boiler Ends as a basic scale. More details will follow later."

Brian ends his letter by commenting on Clock Kit Pendulum Rods [Part 252]:

"These are very expensive to buy, but they have some good constructional points in their favour. They are extremely light, and are invariably true and straight. They also polish-up well, and look good in bracing and cross-ties."

We look forward to hearing the results of Brian's labours.

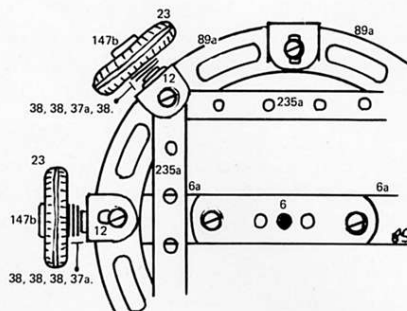

ROLLER BEARINGS AND CAMS

Now, a number of items from Pierre Couroble of Tourcoing, France.

First, a design for a roller bearing that utilizes Hub Discs and ½" Tyres. The Hub Discs act as the roller races; no Bolts should be passed through the flanges or the circumference.

The roller ring is built up from four Stepped Curved Strips [Part 89a], four 3" Narrow Strips, and a compound strip made up of one 1½", and two 2" Strips. Eight ½" Angle Brackets, bolted alternately by their round and elongated holes, hold the Pivot Bolts on which the rollers are mounted. These rollers are ½" loose Pulleys fitted with ½" Tyres [Part 452 or equivalent].

Pierre has also sent designs for a hollow spindle for large cranes, and for various built-up cams. All are reproduced here.

TOP CENTRE: Pierre Couroble's Roller Bearing design.

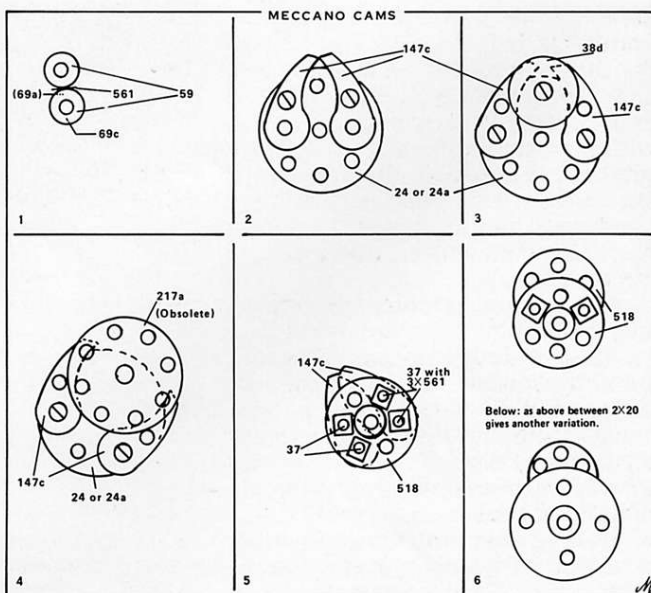

TOP RIGHT: Pierre's Hollow Spindle for large crane models.

RIGHT: Pierre's Cams.

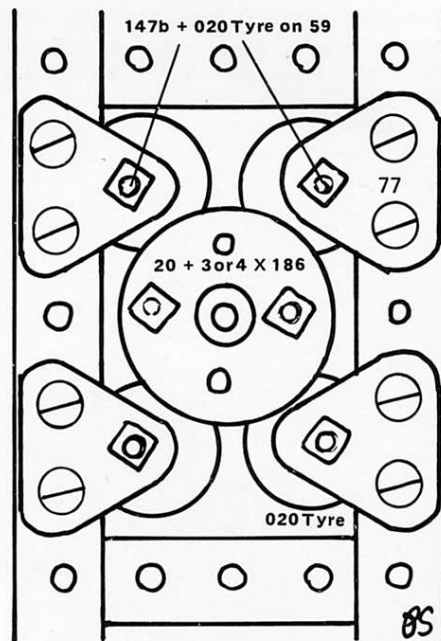

**1: ROTATING SUPERSTRUCTURE
2: SPINDLE**

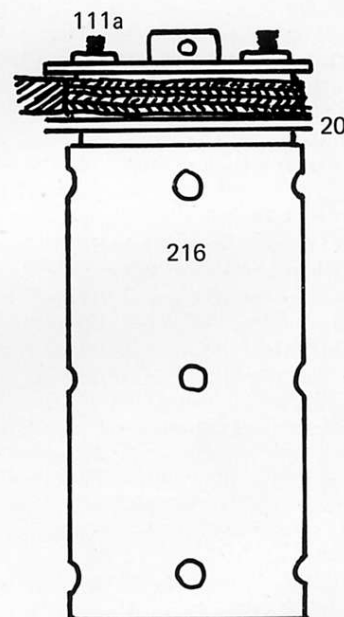

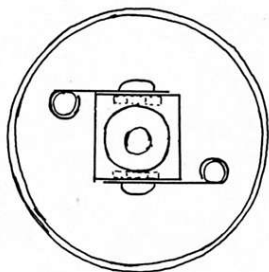
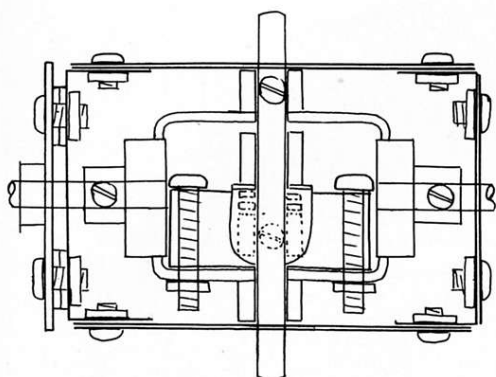

LOW-FRICTION DIFFERENTIAL

This, the second differential design this quarter, comes from Alan Partridge of Sutton Coldfield, England.

"The differential mechanism as ordinarily made", writes Alan, "can be a source of a considerable power loss. As used in an automobile, there is not much of a problem, because most of the time the two half-shafts rotate together, and even when the vehicle is going round a gentle curve, the movement of the Bevels in the cage is much less than the movement of the cage itself.

"However, when the differential is used in combining or adjusting arrangements, with the Bevels moving continually, power loss can be serious. Tooth pressure forces all four Bevels out against the cage, causing increased friction at four points. If, as is common in Meccano, the mechanism is made of two Contrates and two Pinions, tooth pressure still tends to force the Contrates apart.

"Moreover, if the Pinions are on the half-shafts and the Contrates on Pivot Bolts in the cage, the teeth overhang the area of support, and any minor error in construction of the Contrates or the cage may produce a tendency for a Contrate to slew, producing greatly increased friction.

"A further problem is that it may be difficult to get the Bevels or Contrates fully meshed but not binding. Washers thinner than Meccano standard ones may be needed.

"As the writer is making an advanced Orrery (for which *Modelplan 59* was merely a design exercise!) containing about 20 differentials, an early move was to design a layout in which power losses are reduced as far as possible.

"Construction is shown in the accompanying diagram.

"A loose Contrate has a Large Fork Piece joined to it by two Right-Angle Rod and Strip Connectors. The inner ends of the Bolts — and even the Nuts perhaps — which join the Connectors to the Fork Piece need filing to clear a central Collar. This Collar has a $\frac{7}{64}$ " Grub Screw, and any shoulders to the tapped holes must be filed down.

"The side Strips are doubled to assist oil retention. One Double Angle Strip has a Wheel Disc or Strip bolted to it for the same purpose.

"The side Strips are *not* in contact with the bosses of the Contrates. They may need bending out slightly, or Washers put under their ends according to the sizes of the Double Angle Strips and the bosses of the Contrates.

"The input and output shafts carry Pinions (not Bevels or Contrates) so there is no lengthwise tooth pressure on them. Their positions, and that of the cage, need to be stabilized by Washers, which are not shown.

"Each Contrate rotates on pivots which are as far apart as possible. The loose Contrate has the Large Fork Piece to extend its support. The other Contrate is fast on the transverse shaft which is pivoted at the two sides of the cage.

"Tooth pressure is all taken at a single point, between the Large Fork Piece and the central Collar which is fast on the transverse shaft, with Washers between. The transverse shaft is free in the cage. Pressure is automatically equalized at all four points of contact between the two Contrates and the two Pinions. The central Collar, or the fast Contrate, can be set at exactly the position needed to produce good tooth contact and free running."

MECCANO RAILWAY ADVERT
From Andreas Konkoly of Budapest, Hungary, here is a picture of his Meccano Advertising Railway (Special Model N° 12).

"The model runs", says Andreas, "from left to right and vice-versa, controlled by an Automatic Direc-

tion-Change Mechanism. In the meantime the Meccano Advertisement turns; when the railway runs to the left a bell is rung loudly by two hammers".

Andreas is the contributor of the article 'Design for Joy' in this issue.

A PRACTICAL WEAVING LOOM

Richard Callaghan of Cheshire, England, has sent us some (colour) photographs of his loom. He uses the (hand) loom to weave scarves and other useful items, as may be seen from the pictures. Although Meccano parts play a large rôle in this model, Richard has also made extensive use of non-Meccano items.

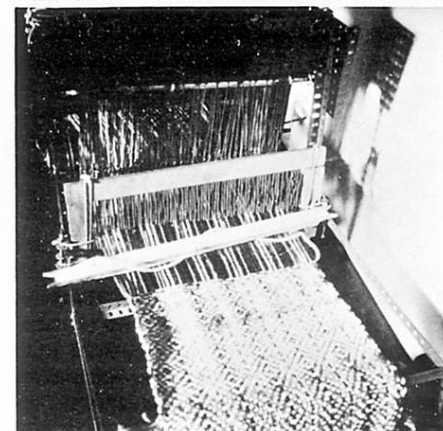
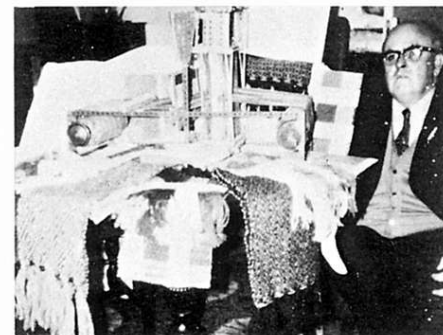

May we here make a plea for readers to send black-and-white photographs for reproduction in the magazine. Our number of colour pages being severely limited at this point due to the sheer expense of the process, we have no choice but to print photographs in black-and-white. Colour originals are very difficult to reproduce well in monochrome (and almost impossible to reproduce well in colour, unless they are of the highest professional quality).

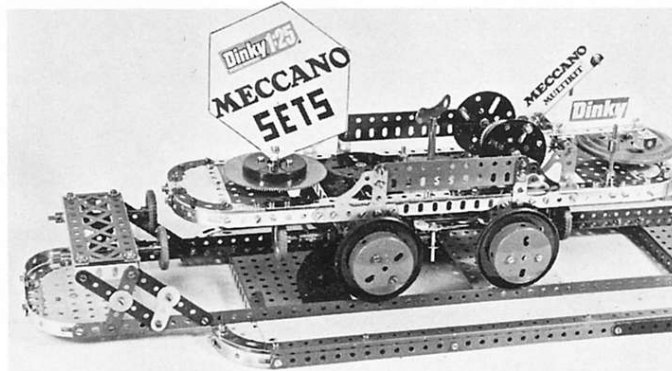

RIGHT: Andreas Konkoly's advertising railway model.

9-Speed and Reverse Gearbox

Described by the Editor

Designed by *Andreas Konkoly*

This model published in 1959 April the French Meccano Magazine firstly. They called in French: 'Boite à 12 Vitesses'. It is incredible: how pass away the time! **Andreas Konkoly**

HEAVY-DUTY VEHICLES, machine tools, drilling machines, etc, all need a wide range of speeds. It was with this special need in mind that this mechanism was designed. The ratios provided are:

FORWARD		REVERSE
12:1	2:1 2:3	2:1
8:1	1:1 1:3	1:3
3:1	4:3 1:9	3:1

BUILDING INSTRUCTIONS

THE GEAR SHAFTS

A 3½" Perforated Strip is bent at a right-angle between holes 2 & 3, and is secured by two Bolts to the 5½" X 2½" Flanged Plate (Figs. 2 & 4).

Referring to Fig. 4, place between the two 2½" Flat Plates the following parts:

Above from left to right: a Rod-with-Keyway is extended by a 2" Rod attached to it with a Coupling. The order of the Gears — all of which are fitted with Key Bolts — is then: a ½" Pinion, a 1½" Gear, and a ¾" Pinion; these are followed by a Collar without its Grub Screw. The next item on the Rod is the end hole of the right-angled Strip mentioned above, which is followed by a Washer, a 60-tooth Gear fixed to the Keyway Rod by its Grub Screw, a ½" Pinion, a Coupling, a 1" Gear, another ½" Pinion, and finally, a Washer.

Below from left to right: a 3½" Rod is freely journalled in the bore of a ½" Pulley-with-Boss, which is fixed by its boss section only to the end of the other Keyway Rod. The order of the parts on the Rod is then: a ¾" Sprocket Wheel, two Collars, three Washers, two more Collars, another Washer, the 2½" Flat Plate, and a further Washer. These are followed by a 1½" Gear Wheel, a ½" Pinion, a 1¼" Gear Wheel, a Washer, a ½" Pulley-with-Boss, and a Washer; all four bossed parts just mentioned are fixed to the Rod by their Grub Screws. The Rod then passes through the right-angled Strip, after which the following parts — all with Key Bolts — are fitted: a 15-tooth Pinion, a 1½" Gear Wheel, a 1" Gear, and a ½" Pinion. These are followed by a Collar, the other 2½" Flat Plate, and finally, a small Fork Piece.

THE REVERSING LAYSHAFT

Between the upper and lower gear shafts, the ½" Pinion which serves as the reversing idler, runs on a ¾" Bolt.

THE SHIFT LINKAGE

The above-mentioned Gears with Key Bolts are slid along the Keyway Rods by means of the frames shown in Fig. 5. The frames are actuated by the gear shift levers seen at the right of that picture.

The frames are situated on shafts as shown in Fig. 5, the nearer pair

being 8" Rods, and the farther pair 6½" Rods. The upper frame is fixed to the upper 6½" Rod by two Collars, and the lower frame is similarly fixed to the lower 8" Rod.

The gear shift levers (Figs. 1 & 5) are each composed of two Couplings joined as shown by a 3" and a 1½" Rod. A pair of Handrail Couplings form the knobs.

Between both Coupling units there is a specially-constructed shaft composed of Collars and Washers locked to a 2" Screwed Rod by Nuts. The exact order of

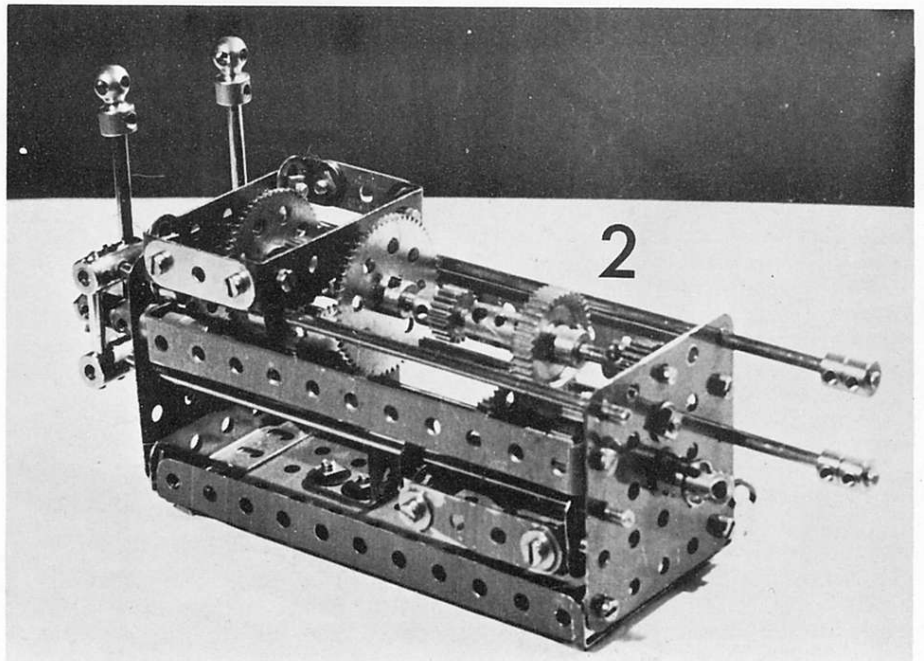
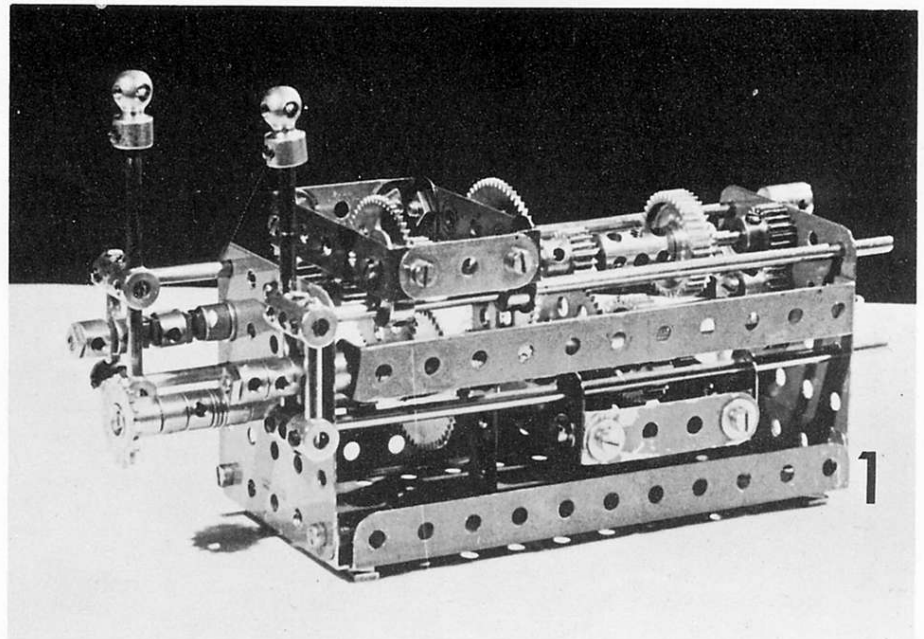

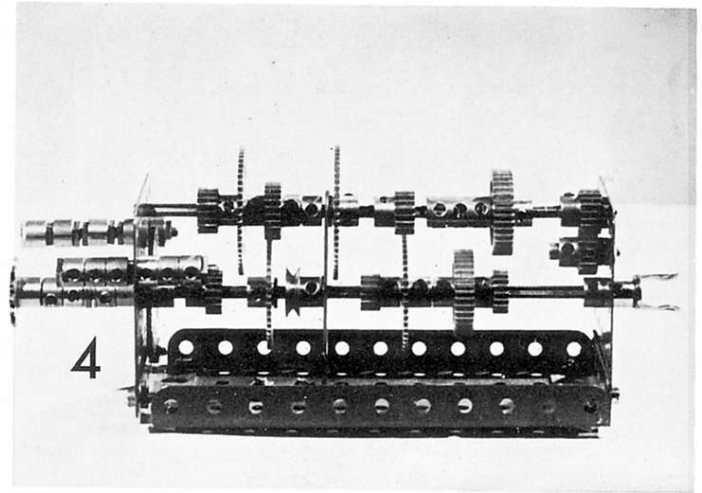
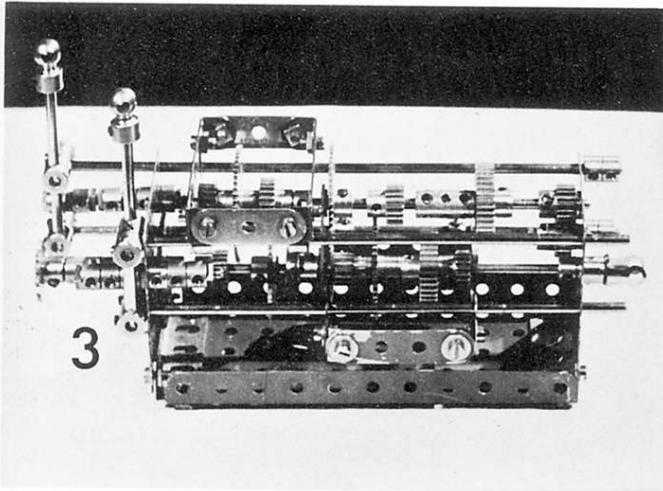

parts on these Rods is as follows:

The Collar row on the left:
Nut, Collar, Nut, Collar, 2 Nuts, Collar, 2 Nuts, Collar, Washer, 2½" Flat Plate, end lug of a 5½" Double Angle Strip, and finally, a Nut.

The Collar row on the right:
Nut, 3 Collars, Nut, 2½" Flat Plate, Collar, end lug of another 5½" Double Angle Strip, 2 Collars, and a final Nut.

COMPLETION AND OPERATION

The other lugs of the Double Angle Strips are fixed to the other Flat Plate as shown in the illustrations.

The required ratio is set with the

two levers. The levers are slid so that the Couplings on them run along the Collar rows.

If it is required to change gear with one lever only, reference should be made to Fig.6, where it will be seen that a 5" Rod has been fitted with a Large Fork Piece, which is in turn fitted to the second Collar of the lower gear shaft with two Nuts and Bolts.

A Coupling is fixed to the Rod as shown, and to this are firmly fixed two Small Fork Pieces by means of ¾" Bolts. The single lever is then swung in an arc so that the required Collar (replacing the Handrail Couplings) is located in its respect-

ive Fork before sliding the selected linkage into gear.

PARTS LIST		
1 of No 3	1 of No 17	2 of No 48d
2 of No 5	2 of No 18a	1 of No 52
2 of No 6	2 of No 23a	26 of No 59
2 of No 6a	1 of No 25	6 of No 63
8 of No 10	6 of No 26	2 of No 72
2 of No 9d	1 of No 26c	2 of No 81
4 of No 12	1 of No 27	1 of No 96a
2 of No 13a	3 of No 27a	1 of No 111
2 of No 14	1 of No 27d	2 of No 111a
1 of No 15	2 of No 31	1 of No 116
1 of No 16	30 of No 37b	3 of No 116a
2 of No 16a	45 of No 37c	2 of No 136a
2 of No 16b	21 of No 38	2 of No 230
	2 of No 48a	7 of No 231

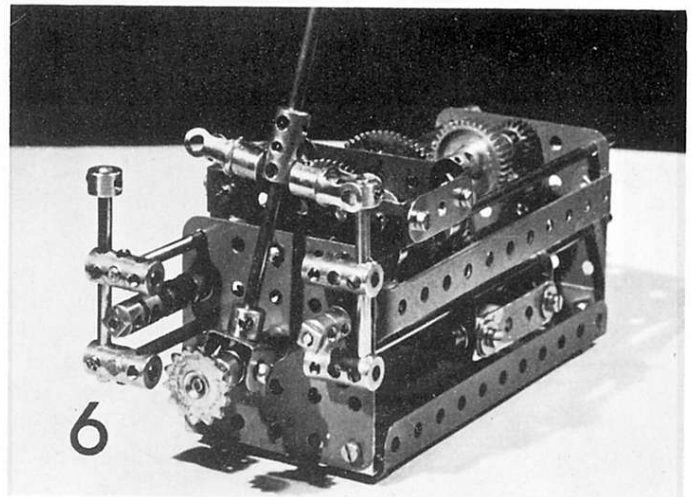
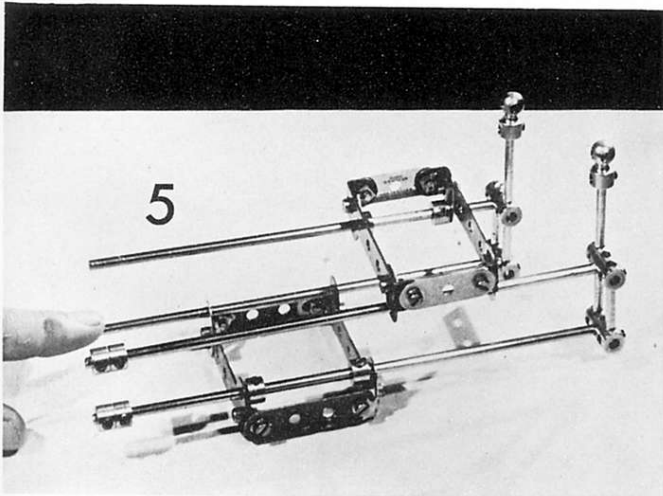

MM COMPETITION

A MECCANO CONSTRUCTION PUZZLE
DEvised BY ALAN PARTRIDGE

WIN
A 1.5 - 4.5 v
Mk 2 JUNIOR
POWERDRIVE
MECCANO
'(CRANE)
MOTOR

Can you build a differential mechanism, which would serve to connect the propeller shaft of a motor vehicle to the half-shafts carrying the rear wheels, using only four toothed parts?

The crown wheel and its driver, or equivalent, are included in the total of four, and only standard Meccano parts are to be used, without mutilation, and in conventional alignments. The drive is to be completely positive: no cords or

frictional devices are allowed.

The first correct answer (described on paper please) that we receive, wins the Motor.

Alan Partridge assures us that it is possible, and that he will reveal the solution in time for us to print it and announce the winner in the next MM. Meanwhile, he asks distracted readers not to send a strong-arm squad to the Midlands, as the drawing is in his bank, and he himself, like any good mechanism, will not squeal!

The competition (which is not open to Alan Partridge!) closes on March 1st.