

Three motorised models in Meccano by Spanner

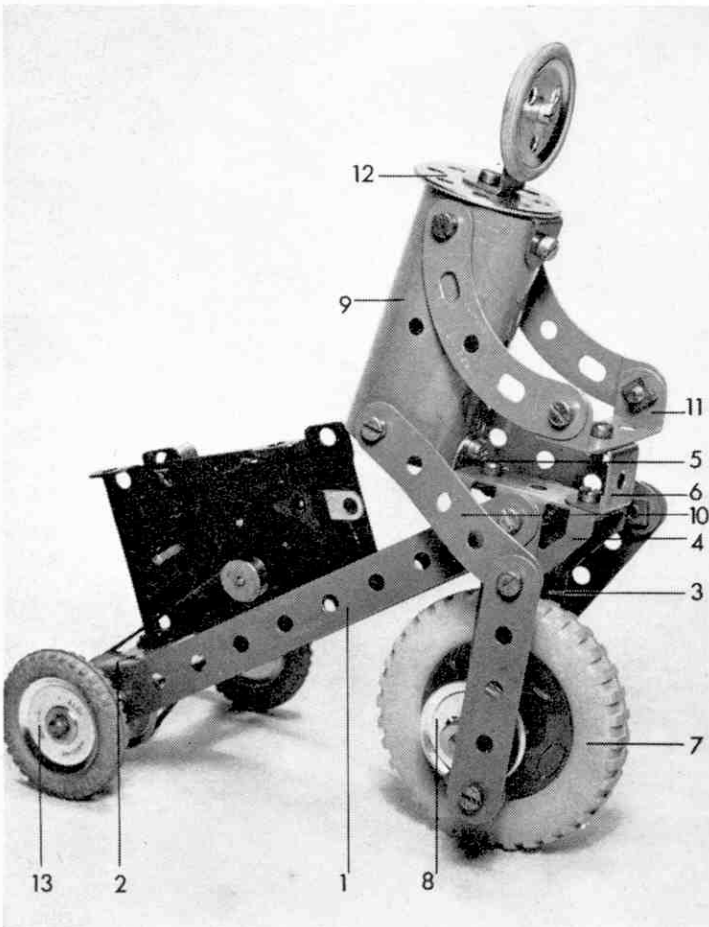
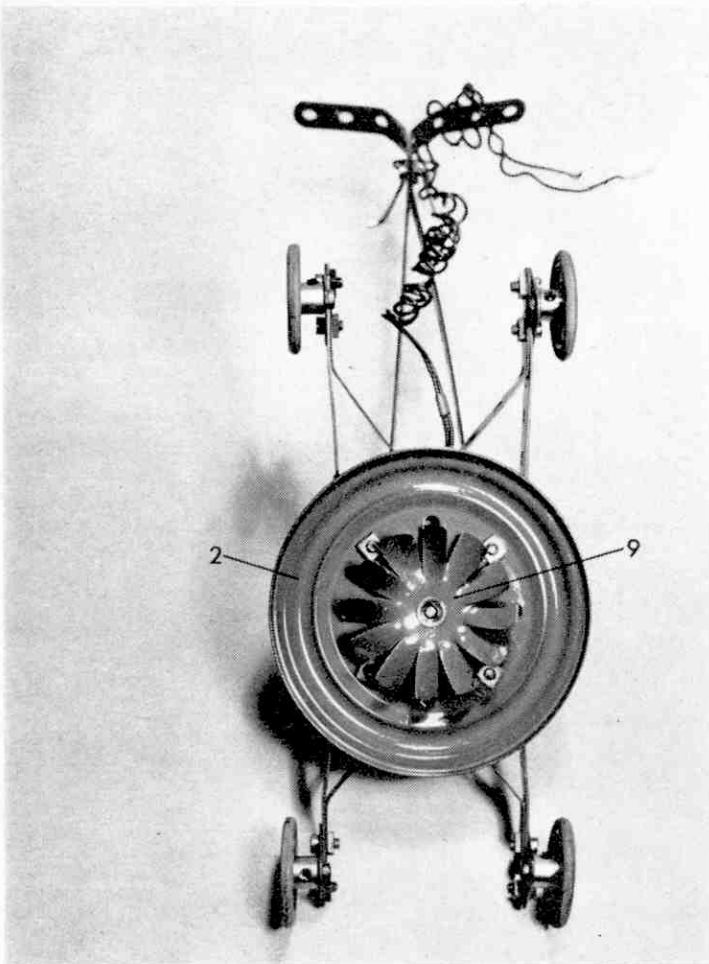

holding an Angle Bracket 5 and a Double Bracket 6 in place.

Journalled in the end holes of Strips 3 is a 2 in. Rod, carrying a 2½ in. Road Wheel 7 between the Strips. The Rod is held in place by two 1 in. Pulleys with boss 8, but note that one of the Pulleys is spaced from the appropriate Strip by three Washers. Before fitting the Pulleys, an Angle Bracket should be fixed to each boss, and this is done by placing the hole in one lug of the Angle Bracket over one tapped bore in the boss of the Pulley. A Nut is then placed on the Angle Bracket, to coincide with the holes, and a Bolt is screwed through the Nut into the boss of the Pulley.

Bolted to the vertical lugs of Angle Bracket 5 is a Cylinder 9 to which two bent 2½ in. Strips 10 are lock-nutted. Another 2½ in. Strip is lock-nutted to the opposite end of each Strip 10 and its other end, in turn, is lock-nutted to the free lug of the Angle Bracket attached to Pulley 8. Arms are provided by two 2½ in. Stepped Curved Strips joined by a 1½ in. by ½ in. Double Angle Strip 11, which is bolted to Double Bracket 6. The head is a 1 in. loose Pulley with Rubber Ring, attached to an 8-hole Wheel Disc 12 by a 1 in. by ¼ in. Angle Bracket. The Wheel Disc is, in turn, fixed to the Cylinder, also by a 1 in. by ½ in. Angle Bracket.

Finally, a Magic Motor is secured with the help of an Angle Bracket to Double Angle Strip 2 and the Pulley on its output shaft is connected by a 2½ in. Driving Band to a 1 in. Pulley on a 3½ in. Rod journalled in the end holes of Strips 1. This Rod is secured by two 1 in. fixed Pulleys 13, each carrying a Motor Tyre.

PARTS REQUIRED

2 of No. 2	1 of No. 22a	2 of No. 30a
6 of No. 5	1 of No. 24a	2 of No. 126
1 of No. 11	36 of No. 37a	2 of No. 142c
4 of No. 12	30 of No. 37b	1 of No. 155
2 of No. 12b	3 of No. 38	1 of No. 186
1 of No. 16	1 of No. 48	1 of No. 187
1 of No. 17	1 of No. 48a	1 of No. 216
5 of No. 22		

WALKING BARROW BOY

Outfit No. 1 contains all the parts needed to build our second model which I have titled 'Walking Barrow Boy'. This name, incidentally, is quite reasonable when you consider that the model comprises a car or barrow which is pushed by a figure that actually walks. The barrow, itself, consists of a 5½ in. by 2½ in. Flanged Plate, to each side flange of which two 5½ in. Strips 1 and 2 are attached by one end. These Strips are 'fanned' outwards at their other ends, as shown, with Strip 1 being nearest the Flanged Plate. Strips 2 at each side are then joined by a 2½ in. Strip, attached to Strips 2 by Angle Brackets 3, after which a Flat Trunnion 4 is bolted to the end flange of the Plate to enclose the resulting gap. A Magic Motor is fixed to the underside of the Flanged Plate, while two Fishplates are bolted to its side flanges to provide bearings for a 3½ in. Rod 5, held in place by a 1 in. fixed Pulley.

In the case of the barrow boy, two 2½ in. by ½ in. Double Angle Strips 6 are joined together to form a rectangular box, to the upper end of which a Trunnion 7 is bolted. A Flat

NO mechanically-minded person can deny that building models with Meccano is not only educational, but is also great fun. Experience shows, however, that the enjoyment obtained from making static or even hand-driven models is much less than the enjoyment obtained from motor-driven examples. In other words, you can't beat building a model; motorising it, and watching it work away under its own power!

Meccano Limited manufacture several motors, both clockwork and electric, which are specially designed for use with the Meccano system. Some, of course, are larger and more powerful than others, but of particular interest to the younger builders are the small 'Magic Clockwork Motor' and the equally compact 'Emebo Electric Motor'. You will find both these units featured in the three simple models described below, the clockwork example in two of them and the electric motor in the third.

TRICK TRICYCLIST

Model No. 1 is a re-built version of the 'Trick Tricyclist' which appeared in the M.M. more than twenty years ago. I never could understand why he was described as 'trick' unless it's because he's learned the trick of pedalling away furiously when all the time his bike's really powered by a Magic Motor! To build it, two 5½ in. Strips 1 are connected through their second holes from one end by a 2½ in. by ½ in. Double Angle Strip 2. At its other end, each Strip 1 is bolted to a 2½ in. Strip 3, at the same time fixing a Trunnion 4 in position. Trunnions 4 are then joined together as shown, the securing Bolts also

Trunnion 8 is attached to this Trunnion by an Angle Bracket, then another Angle Bracket is used to fix a 1 in. Pulley with boss to the top of the Flat Trunnion. The right leg is provided by a 2½ in. Strip 9, bolted to the corresponding Double Angle Strip, with a Fishplate acting as the foot. The left foot, however, is a 1 in. fixed Pulley with Rubber Ring 10, attached by a Fishplate to another 2½ in. Strip. At its other end this Strip is lock-nutted to an 8-hole Bush Wheel 11, mounted on a 2 in. Rod journalled in Double Angle Strips 6 and held in place by a ½ in. Pulley with boss 12. This Pulley, by the way, is not contained in the outfit, but is sold with the Motor.

As in the case of the Tricyclist, two 2½ in. Stepped Curved Strips 13 represent the arms, these being bolted to Double Angle Strips 6. Hands are provided by two Angle Brackets which, besides being bolted to the arms, are also tightly fixed to the Flanged Plate. Lastly, the Pulley on the Motor output shaft is connected by a Driving Band to Pulley 12.

PARTS REQUIRED

4 of No. 2	1 of No. 23a	2 of No. 90a
4 of No. 5	1 of No. 24	1 of No. 111c
4 of No. 10	29 of No. 37a	1 of No. 126
5 of No. 12	29 of No. 37b	2 of No. 126a
1 of No. 16	2 of No. 38	1 of No. 155
1 of No. 17	2 of No. 48a	1 of No. 186a
4 of No. 22	1 of No. 52	1 Magic Motor

MOTOR MOWER

The last model, based on a rotary-type motor mower and powered by an Emebo Electric Motor is one which I found quite fascinating, although it is not built from any particular outfit. Two 7½ in. Strips 1 are fixed by Angle Brackets to the Flanged Disc 2 of a Ball Thrust Race by Angle Brackets. To each end of the Strips a 1 in. Triangular Plate 3 is fixed, at the same time securing a 2½ in. Strip 4 in position. This last Strip is bent inwards, as shown in the accompanying illustration, while a 1 in. fixed Pulley with Rubber Ring 5 is loosely attached to the Triangular Plate by a ¾ in. Bolt passed through its apex hole and held in the boss of the Pulley by a Grub Screw.

Two Corner Angle Brackets 6, one left-hand and one right-hand, are now bolted to Strips 1 in the positions shown. An Angle Bracket 7 is fixed by a Nut and Bolt to the underside of the centre lug of each Corner Bracket, but is spaced from the lug by two Washers. A 7½ in. Strip 8 is bolted to the free lug of each Angle Bracket 7, these Strips being connected towards their other ends by a Bolt passed through their fifth holes. The ends of Strips 8 are bent outwards to form a handle. Fixed to the upper lugs of Corner Angle Brackets 6 are two Fishplates, to which an Emebo Motor is secured by ¾ in. Bolts, with the output shaft of the Motor projecting through the hole in the centre of Flanged Disc 2. A Fan 9 is mounted on the end of the output shaft to act as the cutting tool.

PARTS REQUIRED

4 of No. 1b	25 of No. 37b	1 of No. 154b
4 of No. 5	10 of No. 38	4 of No. 155
2 of No. 10	4 of No. 77	1 of No. 157
4 of No. 12	4 of No. 111c	1 of No. 168a
4 of No. 22	1 of No. 154a	1 Emebo Motor
25 of No. 37a		

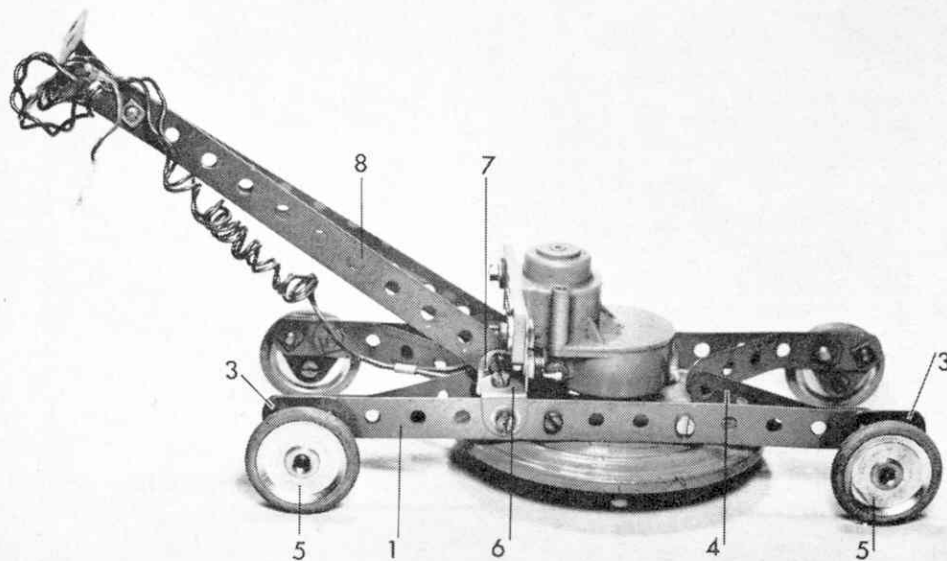
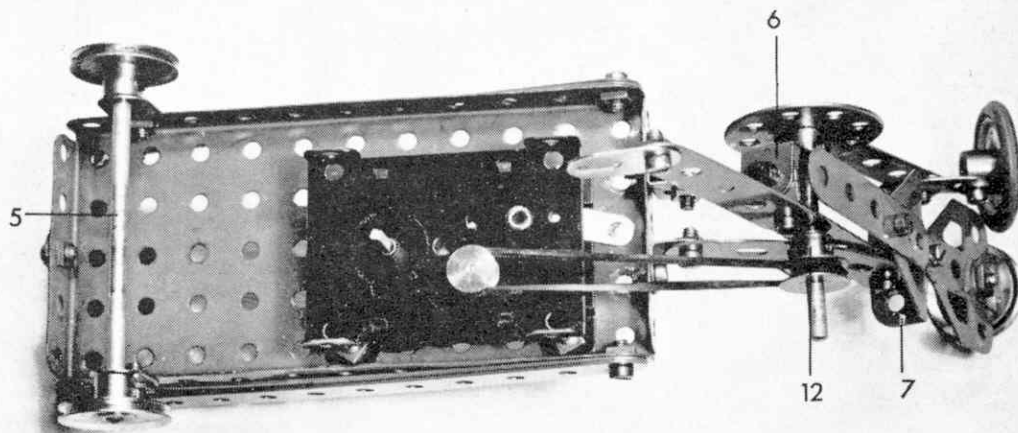
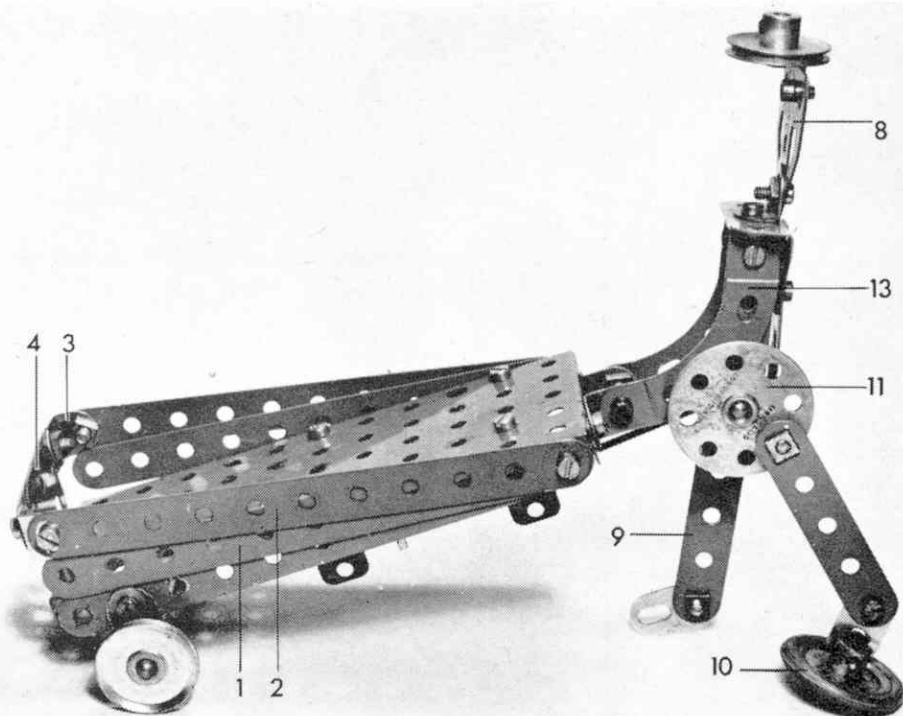

Among the Model Builders with Spanner

REGULAR readers of these pages will perhaps have noticed that, since we re-introduced 'Among the Model-Builders', I have devoted most of the allotted space to gear boxes and mechanisms which, although not complete models in themselves, were sufficiently self-contained to be incorporated as a whole in existing models. This month, therefore, I propose to feature two or three small units that will prove extremely useful in improving existing constructions, but which are not self-contained mechanisms.

Our first two offerings come from a very experienced modeller of longstanding, Mr. H. J. Halliday of London, S.E.15, and are both units specially designed for use with Meccanograph designing machines. The first (see diagram 1) is a modification to the type of 'crown head' found on Meccanographs in which the pen arm is given its oscillating sideways movement by the action of a built-up cam knocking against the pen arm. This system was actually used in the Spiralgraph described in the M.M. last month, the 'cam' in that case being the two 8-hole Bush Wheels through the faces of which a number of Bolts were passed, the pen arm engaging with these Bolts. Mr. Halliday's modification greatly increases the fine, close-knit linework it is possible to produce as it allows a specific pattern to be drawn and then allows the pen to be moved without altering the setting of the model. The identical pattern can then be repeated, but in a different place, thus improving the whole effect.

To build the unit, the existing crown head or cam arrangement on the Meccanograph must be removed, leaving only the driven Rod 1. A 1½ in. Contrate Wheel 2 is then fixed tightly on this Rod, while eight Rod Sockets 3 are bolted to another 1½ in. Contrate Wheel 4. This latter Contrate is now mounted loose on the Rod, but is held in mesh with Contrate 2 by the action of half a Compression Spring 5, held on the Rod by a Short Coupling 6. Fixed in Rod Sockets 3 are a number of short Rods which replace the Bolts in the original crown head and which strike against the pen arm to provide the oscillating movement. The quantity and positions of the Rods naturally depend on the pattern you wish to produce, whereas the length of the Rods depends on the height of the pen arm.

How to use the modification is fairly obvious. Once the first standard pattern is finished, Contrate 4 is disengaged from Contrate 2 and is revolved a distance of one or more teeth. When the model is re-started, the pattern will be repeated, but in a slightly different position. In fact, Mr. Halliday sums up the matter admirably by saying, '... if the first design is left in place on the revolving table, and relative positions of Contrates 2 and 4 are altered each succeeding design with its slight variation will start in a slightly different place on the paper, and will build up into a design of close, fine lines, which can be terminated as soon as the design reaches the operator's satisfaction.' He went on to make the very important point. 'The pen, of course, should be removed from the paper while the Contrates are being altered, otherwise a 'drag' line occurs in the design.' A point which must be remembered.

Mr. Halliday's second mechanism (see diagram 2), in fact, could be used to overcome this problem, being chiefly designed to allow the pen of a Meccanograph to be moved clear of the revolving work table when the paper is being changed. In addition it can be used to increase the complexity of the pattern. A Handrail Support 1, carrying three spacing Washers, is fixed in the end hole of the pen arm, while another Handrail Support 2 is fixed in the fourth hole from the end. A 1 in. Rod 3, on which a ¾ in. Contrate Wheel 4 is mounted, is secured in the latter Handrail Support. Free in

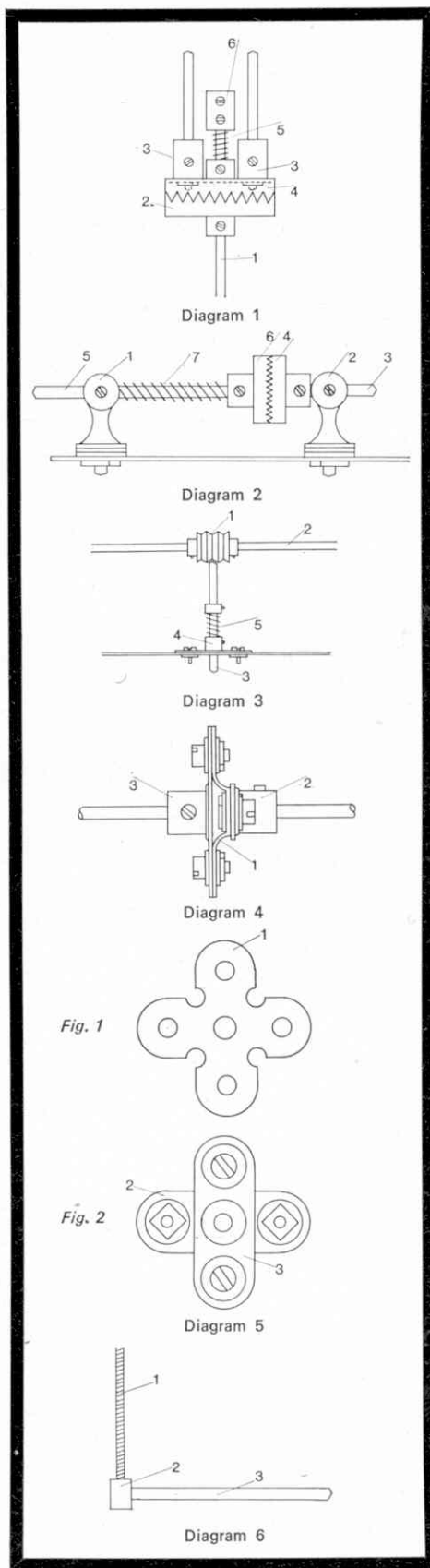

Handrail Support 1, on the other hand, is a 1½ in. Rod 5 that carries another ¾ in. Contrate Wheel 6 on its inside end with a Compression Spring 7 between the Contrate and the Handrail Support. The Compression Spring keeps Contrate 6 in mesh with Contrate 4.

The pen holder is, of course, fixed on the outside end of Rod 5. For a pen holder, Mr. Halliday used the boss from an old 2 in. Pulley which he bored out to fit a ball-point pen, and which was mounted on the Rod by means of a Rod Socket screwed into one transverse tapped bore of the boss. I imagine, however, that a Small Fork Piece mounted on the end of the Rod would be quite suitable.

Operation of the attachment is simple. When the paper is to be changed, Contrate 6 is disengaged from Contrate 4. The pen is then turned to the horizontal position, and the Contrates are re-engaged. In normal operation, of course, the pen is in the vertical position so, to increase the complexity of the pattern, just move it slightly away from the vertical by turning Contrate 6 round a couple of teeth. As with the crown head, the same pattern will be drawn, but on a different line.

POSITIVE GEAR CHANGE

On a different subject, one of the disadvantages of a Meccano gear box is that gear changes sometimes tend to be rather sloppy and also it is often rather difficult to hold a specific gear in mesh. Mr. T. Holland of Swinton, Yorkshire, has designed a simple and very useful mechanism (see diagram 3) that effectively solves the problem. It consists basically of a tension device acting on the sliding layshaft of the gear box. A number of ½ in. or 1 in. Pulleys without boss 1, one for each gear are, mounted free on the layshaft 2, being held in place by Collars. A Rod 3, the shorter the better, is then mounted loose in the boss of a Double Arm Crank 4 bolted to the frame of the gear box and a Compression Spring 5 is slipped onto this Rod to be held by a Collar. The end of the Rod simply engages with the Pulleys to hold the layshaft stationary. The Rod, however, must be able to slide from one Pulley to another, therefore, the Compression Spring must be adjusted so as to keep tension as light as possible.

UNIVERSAL COUPLING

Diagrams 4 and 5 on this page shows an extremely useful, if slightly unusual, small universal coupling which has been designed by Mr. C. R. Jacob, of Streatham Hill, London, S.W.2. As Mr. Jacob points out, the standard Meccano universal joint is far too long for some models and, in such cases, the item illustrated makes an excellent substitute. The only disadvantage—if it can be called a disadvantage—is that it is rather large in diameter, but this is far outweighed by its short length.

It consists quite simply of a piece of leather 1 cut to the shape shown in fig. 1 (diagram 5) and bolted between two Double Arm Cranks 2 and 3 arranged at right-angles to each other. To avoid the smooth bores in the bosses of the Crank being out of line or 'eccentric', however, it is advisable to assemble the unit on a Rod. The first Crank is mounted on the Rod to be followed by the piece of leather, two opposite lugs of which are then bolted to the arms of the Crank with a Washer between the bolthead and Crank and another Washer between the leather and Nut. The second Double Arm Crank is then added to the Rod and similarly bolted to the other lugs of the leather piece. The thickness of the leather, incidentally, should be about 2 m.m., but this measurement is not critical.

HINT FOR YOUNGSTERS

Lastly, this month, I should like to pass on a useful hint to young builders or newcomers to the Meccano hobby, which has been sent in by Mr. R. Lowe of Gorton, Manchester 18. Mr. Lowe writes, 'sometimes when building a model a Collar or Gear Wheel is required on a shaft which is very awkward to get at. I thought of a simple way to overcome this (problem) by using a Screwed Rod as shown in the diagram'. (See diagram 6.)

This solution of Mr. Lowe's is easy and effective. All you do is screw the Screwed Rod 1 into one transverse tapped bore of the Collar or Gear and, using the Rod as a handle, slide the part 2 onto the shaft in question 3. The Screwed Rod can then be removed or, if required, can be used to hold the part steady while the Grub Screw is tightened.

IDEAS STILL WANTED

Finally, I should like to remind readers that I am still only too pleased to receive any material for publication in these pages. Nothing is too insignificant for consideration so, if you have designed anything, no matter how small and simple, don't hesitate to send details to me, addressed to Meccano Magazine, Binns Road, Liverpool 13. After all, as I have said before, we can't feature an 'Among the Model-Builders' article every month without hearing from you, the model-builders!

Steam for Ships—from page 35

ing a 2½ in. by ½ in. Double Angle Strip to which two Double Brackets are bolted. Fixed on to the lugs of these Double Brackets are eight 1½ in. Strips 43, arranged as shown in two groups of four to represent the crosshead. A Double Arm Crank 44 is added to the underside of the Double Angle Strip and a 4½ in. Rod, free to slide in the bosses of upper Face Plate 22 and Face Plate 23, is secured in its boss.

Journalled in Strips 16 is a 3 in. Rod 45 with a Coupling 46 in its centre and a Double Arm Crank 47 on one end. Fixed in the longitudinal bore of the Coupling is a 1 in. Rod, on the end of which a Collar is held by two Bolts screwed into its tapped bores. Each of these Bolts carries on its shank two Washers and a 1½ in. Strip 48 which must be free on the Bolt. At their upper ends, Strips 48 are joined by another Bolts/Washers/Collar arrangement, the Collar carrying a 3½ in. Rod 49, that slides in Handrail Support 25 and the boss of Large Fork Piece 29.

Lock-nutted to Double Arm Crank 47 is a 1 in. by 1 in. Angle Bracket, one lug of which is extended by a 2 in. Strip and a Single Throw Eccentric 50, the latter mounted on the end of a 3½ in. Rod 51 journalled in Strips 17 and held by a Collar. Bolted to the other lug of the Angle Bracket are two 1 in. by ½ in. Angle Brackets, to which a 5½ in. Curved Strip 52 is fixed. This represents what, on the original full-size engine, was the reversing lever, but it does not actually reverse the model.

MOTOR MOUNTING

Two 7½ in. Angle Girders 62 are joined by a 4 in. Flat Girder 63, attached by Angle Brackets, but note that the Flat Girder is positioned at one end of the Angle Girders. Bolted between the Angle Girders at their other end is a No. 1 Clockwork Motor with a ½ in. Pinion on its output shaft. In mesh with this Pinion is a 57-teeth Gear Wheel 64, mounted on a 2 in. Rod journalled in the Motor side plates and held by a Collar. Gear 64 is another example of an old part. Fixed on the end of the Rod is a driving pinion 65 from a No. 1 Clockwork Motor.

The completed engine is now screwed to a wooden baseboard with dimensions of approximately 9 in. by 7 in., remembering to leave sufficient room for the Motor mounting to be screwed alongside it. The mounting is positioned so that the driving pinion 65 engages with Gear Wheel 34, and is raised to the correct height by several strips of rubber packed beneath Angle Girders 62. These rubber strips also serve to reduce running noise enormously. I should imagine, incidentally, that the wooden base-

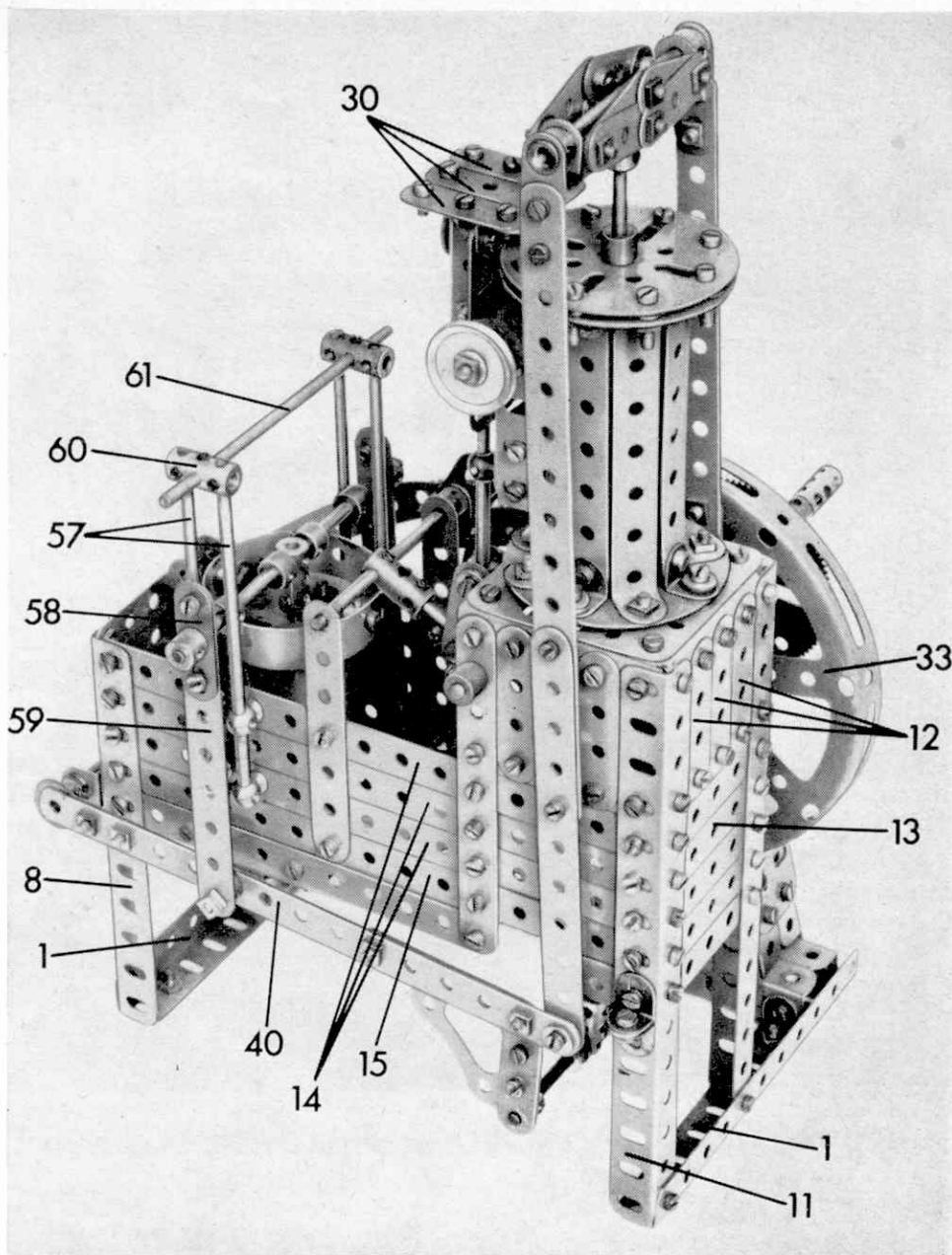

board used by Mr. Sanders could be replaced by a built up Meccano base. I leave this up to you to design, however.

THE PUMP

Beneath the model, two 1½ in. Corner Brackets 53 are fixed one each to two 2 in. Angle Girders which are, in turn, fixed to Strips 18, then a Cylinder is attached to the Corner Brackets by Angle Brackets. Attached to the top of the Cylinder, also by Angle Brackets, is a Boiler End 54, across the inside of which a 1½ in. by ½ in. Double Angle Strip 55 is fixed by ½ in. Bolts, a Collar on the shank of each Bolt acting as a spacer. A Double Bracket 56 is added on the outside being attached by an Angle Bracket.

Sliding in the centre holes of Double Angle Strip 55 and the Boiler End is a 2½ in. Rod, carrying a Coupling at its end. A 5 in. Rod is loose in the upper transverse bore of this Coupling, but is prevented from sliding about by two Collars. The ends of the Rod are each located between two 4½ in. Rods 57, mounted in Handrail Supports bolted to Strips 14, then Double Arm Cranks 58, extended by 4½ in. Strips 59, are fixed in position, as shown. The lower ends of Strips 49 are lock-nutted, with ½ in.

Bolts, to Strip 40, a Collar on the shank of each Bolt separating the two Strips from each other. The upper ends of Rods 57, on the other hand, are joined by Couplings 60, which are themselves connected by a 4½ in. Rod 61.

PARTS REQUIRED :

10 of No. 1b	3 of No. 16b	2 of No. 103h
8 of No. 2	1 of No. 17	2 of No. 108
4 of No. 2a	1 of No. 18a	3 of No. 109
5 of No. 3	1 of No. 22	2 of No. 111
12 of No. 5	1 of No. 26	14 of No. 111a
11 of No. 6	1 of No. 27a	1 of No. 111d
15 of No. 6a	1 of No. 27c	1 of No. 116
8 of No. 8b	258 of No. 37a	1 of No. 118
4 of No. 9	237 of No. 37b	1 of No. 130a
2 of No. 9b	50 of No. 38	2 of No. 133
7 of No. 9d	2 of No. 38d	9 of No. 136
3 of No. 9e	1 of No. 48	1 of No. 162a
1 of No. 9f	2 of No. 48a	1 of No. 164
7 of No. 11	5 of No. 48b	1 of No. 216
23 of No. 12	17 of No. 59	1 of No. 1
1 of No. 12a	6 of No. 62	Clockwork
2 of No. 12b	5 of No. 62b	Motor
1 of No. 14	7 of No. 63	1 of No. 1
1 of No. 15	1 of No. 64	Clockwork
6 of No. 15a	1 of No. 89	Motor
4 of No. 16	3 of No. 103c	driving
1 of No. 16a	2 of No. 103f	pinion