

(530) A Novel Three-Speed and Reverse Gear-Box

(S. Tonkin, Bristol).

The compact gear-box shown in Fig. 530 employs only a few gears, but provides three different forward speed ratios and one in reverse. A suitable casing for the mechanism, such as that shown in the illustration, should first be constructed. The driving shaft is a 3" Rod 1 that carries a 1/2" x 3/4" Pinion 2, a 3/4" Pinion and a 1" Gear, which are fixed to it in the positions shown. A 1/2" Pinion is pivoted on a 3/8" Bolt fixed to the casing, and meshes with the

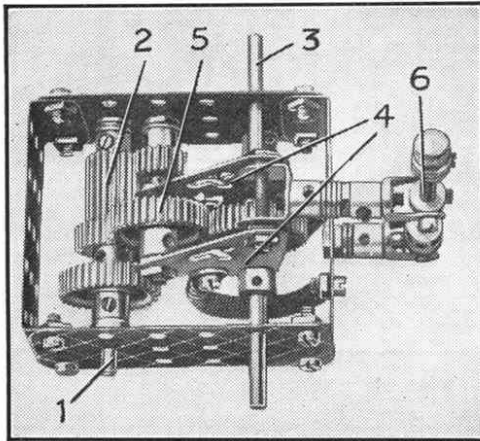

Fig. 530.

Pinion 2. The layshaft, which is also the driven shaft, is a 4" Rod 3, and it carries a 1" Gear and two 1 1/2" Corner Brackets 4 spaced from each side of the Gear by Washers and held in place on the Rod by two Collars. This Gear meshes with another 1" Gear 5 that is free to rotate on a 1" Screwed Rod held in Corner Brackets. Two Springs bolted to the Corner Brackets pass around a 3" Rod and are then attached to the gear-box casing.

The Corner Brackets 4 are also attached to a 1" Screwed Rod, on which is a Large Fork Piece that is lock-nutted by means of a 1 1/2" Bolt and Nuts to the boss of a Swivel Bearing. The Swivel Bearing is attached to the selector Rod 6, the lower end of which is inserted in a Universal Coupling fixed to the casing by a Threaded Pin.

To engage a particular gear train the selector is first moved to the right, as seen in the photograph, thus releasing Gear 5 from engagement. For a lower gear or for reverse ratio the selector is then moved away from the operator, while for a higher gear ratio it is pulled towards him.

The drive may be transmitted from the driven shaft 3 to the model in which the mechanism is incorporated by meshing a 1/2" x 3/4" Pinion, mounted on the Rod with a similar Pinion fixed on a Rod journaled at one of its ends in the gear-box casing.

The advantages of this type of gear-box over the more usual kinds are that gear changing is silent while working at any speed, and there is less wear of the teeth of the gears than in the more conventional types where the gears are slid into mesh while rotating.

Another interesting feature of this gear-box is that the Gears and Pinions are held in mesh by two Springs, which prevent any tendency of the teeth to "climb" under normal loads.

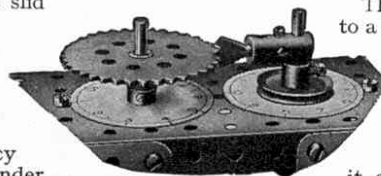

Fig. 531.

(531) Intermittent Rotary Striker

("Spanner")

Distance indicators, revolution counters and such-like recording instruments usually incorporate some form of intermittent striking mechanism. This may be a simple ratchet movement, or one that is more complicated. One of the simple devices suitable for the purpose is shown in Fig. 531, and in this example it is applied to a distance-recording apparatus. In this model the axle of one pair of road wheels carries a Worm that meshes with a 1/2" Pinion driving a short vertical Rod. The Rod is journaled in one of the holes in the Flanged Plate forming the base, and also in the centre hole of a 2 1/2" x 1/2" Double Angle Strip secured underneath the Plate. A 1" fast Pulley is fixed on the Rod so that it bears lightly against the Flanged Plate, and above it is fixed a Coupling.

A Centre Fork in the unoccupied end of the longitudinal bore of the Coupling forms the striker, and as it rotates it engages with the teeth of a 2" Sprocket Wheel, one tooth being "picked" for every revolution of the striker.

The Sprocket Wheel is carried on a 2" Rod journaled in bearings similar to those that carry the striker Rod. At its lower end the Rod is fitted with a second 2" Sprocket Wheel that acts as a ratchet, the pawl being formed from a 2 1/2" Strip bent to the required shape and attached to the base of the model by two nuts and bolts.

Two circles of thin paper are cut and pasted to the base plate, as shown in the illustration, and they are graduated according to the size of the road wheels. If 2" Pulleys with a thin strip of paper pasted round their rims are used as the road wheels, the striker will rotate once for every 10 ft. of travel. The paper disc corresponding to the striker may therefore be graduated into 10 spaces each representing a foot, and these can be subdivided into 12 spaces representing inches.

The disc for the Sprocket Wheel must be divided into 36 spaces, corresponding to the number of teeth on the Sprocket; and each space will then correspond to 10 ft. When calibrated in this way the device is capable of measuring distances up to 360 ft. without repetition.

This mechanism is applicable to a very wide range of models, and with a few adjustments is suitable for incorporation in such models as cyclo-meters, bell striking devices and clocks, where it could be adapted to serve as an escapement.

Suggestions Section

By "Spanner"

(532) A Useful Momentum Motor

("Spanner")

When neither a Clockwork nor an Electric Motor is available for driving models a good substitute is a momentum motor of the type shown in Fig. 532. This gives a very powerful drive and is quite capable of operating models of the lighter kind, such as windmills, simple engines and road vehicles. The power of the motor is derived from the momentum produced in a heavy flywheel caused to revolve at high speed by turning a handle. A clutch is fitted on the handle shaft so that when a sufficiently high speed is reached the handle can be disconnected from the drive and the motor allowed to run freely. The bearings for the various shafts should be designed to suit the requirements of the model in which the motor is incorporated.

The flywheel is a Meccano Flywheel, part No. 132, and it is mounted on a Rod 3 that carries also a 1/2" Pinion 5 meshing with a 57-teeth Gear. The latter is fixed on the inner end of a Rod that carries a 1/2" Pinion 4 at its other end. This 1/2" Pinion meshes

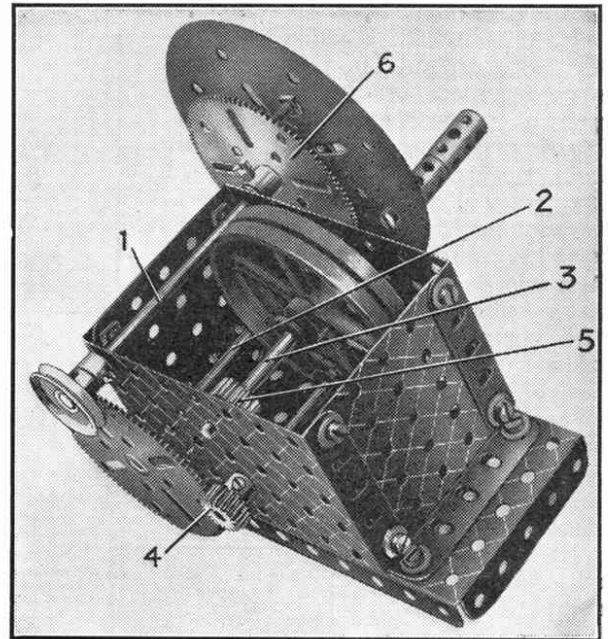

Fig. 532.

with a 2 1/2" diam. Gear fixed on one end of a Rod 2 bearing at its other end a 1/2" Pinion driven from a 2 1/2" diam. Gear 6 on the shaft of the winding handle 1. To this shaft is fixed a 1" Pulley from which the final drive is taken. The handle, formed from Couplings, is attached to a 4" Circular Plate bolted to a Bush Wheel, which is loose on the winding shaft. The Circular Plate is caused to contact the 2 1/2" diam. Gear 6 by pushing the driving handle inwards. This action compresses a Spring placed between the Gear and the Circular Plate, and in so doing causes the shanks of two 3/8" Bolts fixed in the Circular Plate to engage with holes in the 2 1/2" Gear so that it rotates with the Plate.