

# Using the Meccano Gears Outfit "A"

## Mobile Crane

THE realistic crane that forms the subject of our model this month can be built with Outfit No. 4 and a Gears Outfit "A." The travelling movement of the model is operated by a No. 1 Clockwork Motor driving the rear caster wheels, which are also used to steer the crane.

The main frame of the model is formed by two  $12\frac{1}{2}$ " Strips attached at each end by Angle Brackets to  $5\frac{1}{2}$ " Strips 1 and 2. The  $12\frac{1}{2}$ " Strips are extended downward by a  $5\frac{1}{2}$ "  $\times$   $2\frac{1}{2}$ ", a  $4\frac{1}{2}$ "  $\times$   $2\frac{1}{2}$ " and a  $2\frac{1}{2}$ "  $\times$   $2\frac{1}{2}$ " Flexible Plate on each side. The front is completed by two  $5\frac{1}{2}$ "  $\times$   $1\frac{1}{2}$ " Flexible Plates and the rear by two  $2\frac{1}{2}$ "  $\times$   $1\frac{1}{2}$ " Flexible Plates.

The caster unit is carried by a platform formed by a  $5\frac{1}{2}$ "  $\times$   $2\frac{1}{2}$ " Flanged Plate 3. This is bolted direct to  $5\frac{1}{2}$ " Strip 1, and to a similar Strip 4 that is attached to the sides by Angle Brackets.

The floor of the driving compartment is filled in by a Hinged Flat Plate 5 supported by four  $2\frac{1}{2}$ "  $\times$   $\frac{1}{2}$ " Double Angle Strips. Two of these are bolted by their lugs to Strip 2, and the remaining two are fixed one to each side of the model. The shield at the front is assembled from two  $2\frac{1}{2}$ "  $\times$   $2\frac{1}{2}$ " Flexible Plates and is attached by Fishplates to Strip 2.

The jib supports are Flanged Sector Plates extended at their narrow ends by Semi-Circular Plates. They are attached to Trunnions bolted to the Hinged Flat Plate 5 and to Fishplates bolted to Strip 4. Each side of the jib consists of a  $12\frac{1}{2}$ ", a  $5\frac{1}{2}$ ", a  $3\frac{1}{2}$ " and a  $2\frac{1}{2}$ " Strip bolted together as shown. The sides are

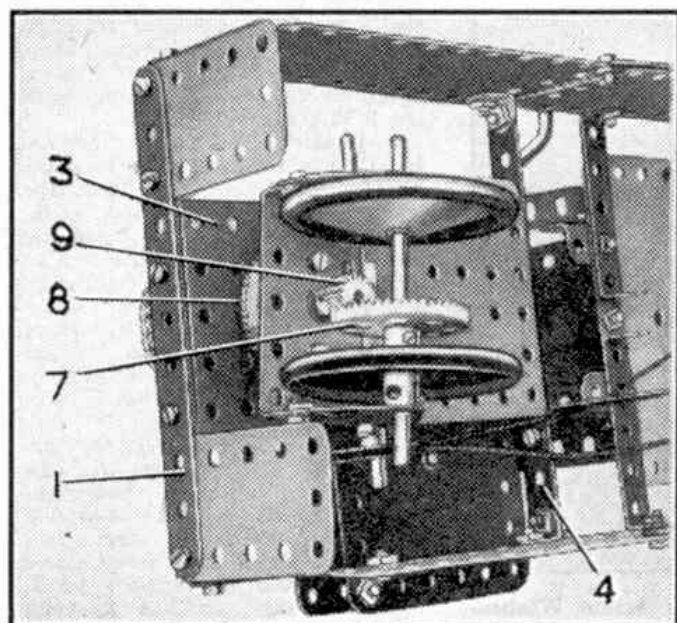

Fig. 2. The caster steering unit showing how the drive is taken to the wheels.

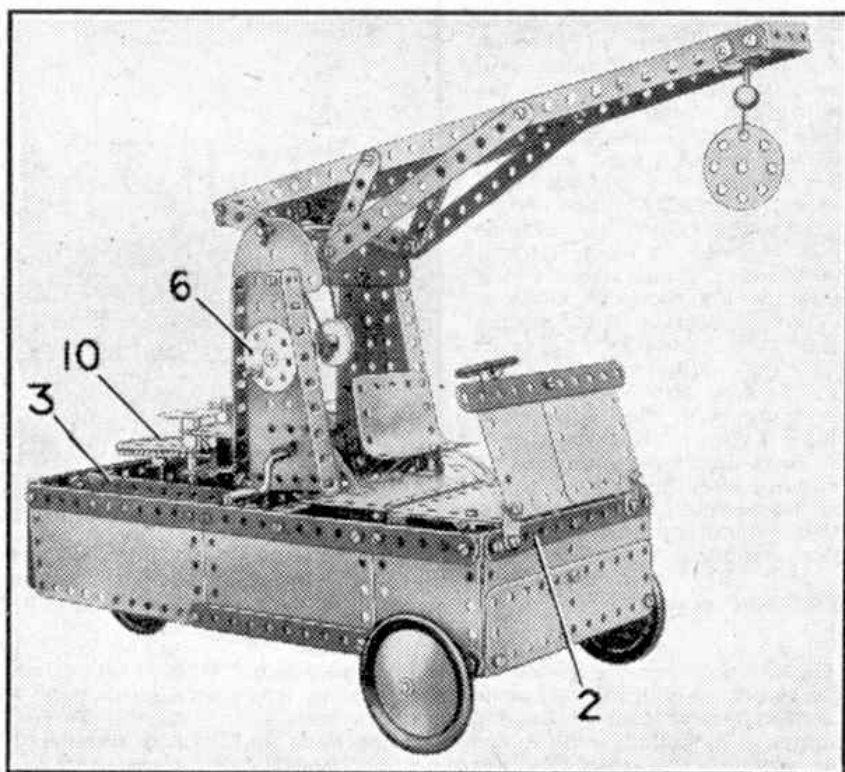

Fig. 1. A Meccano Gears Outfit "A" and an Outfit No. 4 are used in building this fine working model of a mobile crane.

joined at the front and rear by a  $1\frac{1}{2}$ "  $\times$   $\frac{1}{2}$ " and a  $2\frac{1}{2}$ "  $\times$   $\frac{1}{2}$ " Double Angle Strip respectively, and the complete jib is pivoted on a Rod mounted in the Semi-Circular Plates. The jib is luffed by turning a Bush Wheel 6 that is fixed on a Rod mounted in one of the Flanged Sector Plates and in a Reversed Angle Bracket bolted to it. A length of Cord is fastened to the Rod and to the rear of the jib. The jib can be held in any desired position by pushing the Bush Wheel inward so that one of its holes engages a  $\frac{1}{2}$ " Bolt fixed in the Flanged Sector Plate.

Hoisting is operated by a Crank Handle mounted in the Flanged Sector Plates. A length of Cord tied to the Crank Handle is passed over the Rod on which the jib pivots, and round a  $\frac{1}{2}$ " Pulley free to turn on a  $\frac{1}{2}$ " Bolt fixed by nuts to the jib head.

The caster unit is formed by two Flat Trunnions bolted to a  $2\frac{1}{2}$ "  $\times$   $1\frac{1}{2}$ " Flanged Plate, and the wheels are fixed on a  $3\frac{1}{2}$ " Rod mounted in the apex holes of the Flat Trunnions. The Rod carries a  $1\frac{1}{2}$ " Contrate 7. A 57-tooth Gear 8 is attached to the Flanged Plate by  $\frac{1}{2}$ " Bolts, but is spaced from the Plate by two nuts on each Bolt. A 2" Rod is free to rotate in the 57-tooth Gear and the Flanged Plate, and is fitted at its lower end with a  $\frac{1}{2}$ " Pinion 9 arranged to mesh with Contrate 7. The Pinion is spaced from the Plate by three Washers. The upper end of the 2" Rod is passed through Flanged Plate 3 and through a Reversed Angle Bracket bolted to the Flanged Plate. The Rod is held in position by a 2" Sprocket 10.

A No. 1 Clockwork Motor is bolted to a Double Bracket fixed to one of the Flanged Sector Plates, and to a second Double Bracket attached to the side of the model. A  $\frac{1}{2}$ " Pinion on the Motor

## Cash Prizes for Model-Builders

### CHRISTMAS "TOYS AND GAMES" COMPETITION

By the time this issue of the "M.M." makes its appearance the Christmas season will be close at hand, and most of our readers will be eagerly anticipating the annual festival, and the attendant goodwill, presents and parties associated with the season. Toys and games of all kinds are of course a prominent feature, and many humorous toys and exciting games can be built with Meccano. This month therefore we are giving readers the opportunity to try their skill at building models of this kind, and cash prizes will be awarded for the best models submitted. The Ball Game described in the "New Models" section and the Magic Box in the "Among the Model-Builders" pages of this "M.M.," are good examples of the type of models likely to win prizes in this competition.

Model-builders may use any number of parts in building their models, but the prizes will be awarded to the most interesting or humorous toys and games, and the mere size of a model will not affect the judges' decision in any way.

It is not necessary to send the actual model in order to take part in the Contest. A good sketch, or

better still a photograph, is all that is required. This should be sent to "Christmas Toys and Games Contest, Meccano Ltd., Binns Road, Liverpool 13."

Entries will be divided into two sections, for Home and Overseas readers respectively, and the following prizes will be awarded in each section: First, Cheque for £3/3/-; Second, Cheque for £2/2/-; Third, Cheque for £1/1/-. There will be also five prizes of Postal Orders for 10/6 and five of Postal Orders for 5/-.

Entries for the Home Section must reach Liverpool not later than 31st January next, but Overseas entries will be accepted until 31st May 1950.

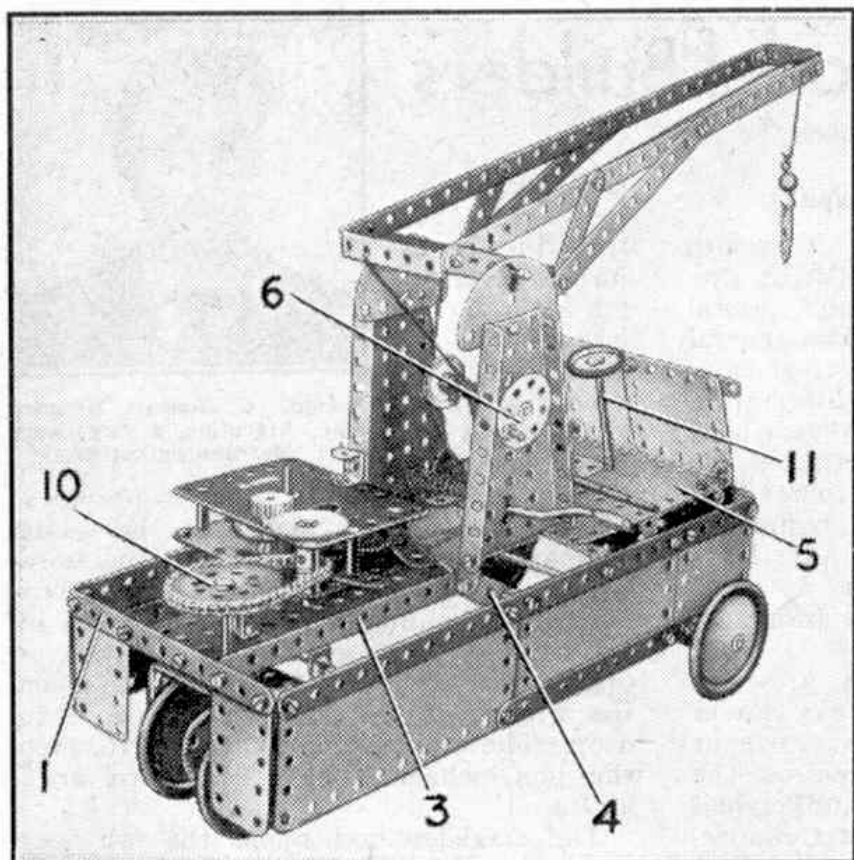

Fig. 3. The mobile crane is driven by a No. 1 Clockwork Motor, which is mounted as shown here.

shaft meshes with a 50-tooth Gear on a  $1\frac{1}{2}$ " Rod mounted in the Motor sideplates. A  $\frac{3}{4}$ " Sprocket fixed on this Rod between the sideplates is connected by Chain to 2" Sprocket 10.

Steering is controlled by a Rod 11 mounted in the centre hole of one half of the Hinged Flat Plate, and in a Stepped Bent Strip 12. The Rod carries a 1" Pulley 13, and an endless belt of Cord links this Pulley to a similar Pulley 14. The Cord passes over a  $2\frac{1}{2}$ " Strip 15 bolted to one of the Flanged Sector Plates. Pulley 14 is fixed on a  $3\frac{1}{4}$ " Rod mounted in a  $2\frac{1}{2}$ " x  $\frac{1}{2}$ " Double Angle Strip bolted to Flanged Plate 3. A Worm 16 is fixed on the Rod and meshes with 57-tooth Gear 8.

The front wheels are fixed on two  $3\frac{1}{2}$ " Rods joined by a Rod Connector and mounted in Curved Strips. The seat is a U-Section Curved Plate bolted to a Formed Slotted Strip attached to Plate 5.

Parts required to build Mobile Crane: 4 of No. 1; 8 of No. 2; 2 of No. 3; 3 of No. 5; 4 of No. 10; 2 of No. 11; 8 of No. 12; 1 of No. 12c; 2 of No. 15b; 4 of No. 16; 2 of No. 17; 1 of No. 18a; 1 of No. 19g; 4 of No. 22; 1 of No. 23; 1 of No. 24; 5 of No. 35; 80 of No. 37; 7 of No. 37a; 7 of No. 38; 1 of No. 40; 1 of No. 44; 1 of No. 48; 6 of No. 48a; 1 of No. 51; 1 of No. 52; 2 of No. 54; 1 of No. 57c; 2 of No. 90a; 4 of No. 111c; 2 of No. 125; 2 of No. 126; 2 of No. 126a; 1 of No. 155; 1 of No. 176; 4 of No. 187; 2 of No. 188; 2 of No. 189; 4 of No. 190; 2 of No. 191; 2 of No. 192; 1 of No. 198; 1 of No. 199; 1 of No. 213; 2 of No. 214; 1 of No. 215; 1 Gears Outfit "A"; 1 No. 1 Clockwork Motor.

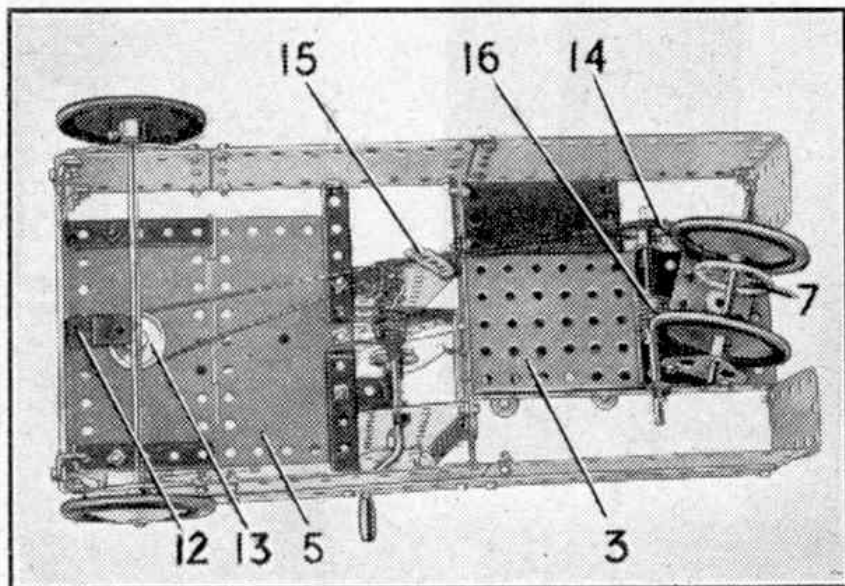

Fig. 4. An underneath view of the crane chassis, showing how the caster unit is operated from the steering wheel.

produces an excellent effect, and will enable the magician to add further to his reputation!

**Constant Mesh Gear-Box for Cranes**

The simple gear-box shown in Fig. 2 provides three separate movements, and is designed specially for model cranes or excavators. Two of the movements are arranged for winding or paying out Cord, and can be used for controlling the load and luffing the jib. Both winding barrels are fitted with independent brakes, and the drive to either of the two winding drums is brought into operation by moving a single control lever. The third movement is arranged so that a drive can be transmitted to slewing or travelling motions.

The outstanding feature of the gear-box is that all three movements are brought into operation by friction clutches. This avoids any possible damage to gears by forcing them into mesh with the teeth out of line, and also enables the drive to be taken up very smoothly without the jerk characteristic of gear engagement.

The gear-box housing is assembled by joining two 3½" x 2½" Flanged Plates together by 4½" x 2½" Flat Plates. The drive from the Motor is transmitted by Chain and Sprockets to the input shaft 1, which is fitted with a ½" diameter, ½" face Pinion 2. The 57-tooth Gears 3 and 4,

A huge model tanker 6 ft. 4 in. long and 9½ in. beam, which was built by Mr. W. Sicker, Zurich, Switzerland. Nearly 800 nuts and bolts are used in its construction.

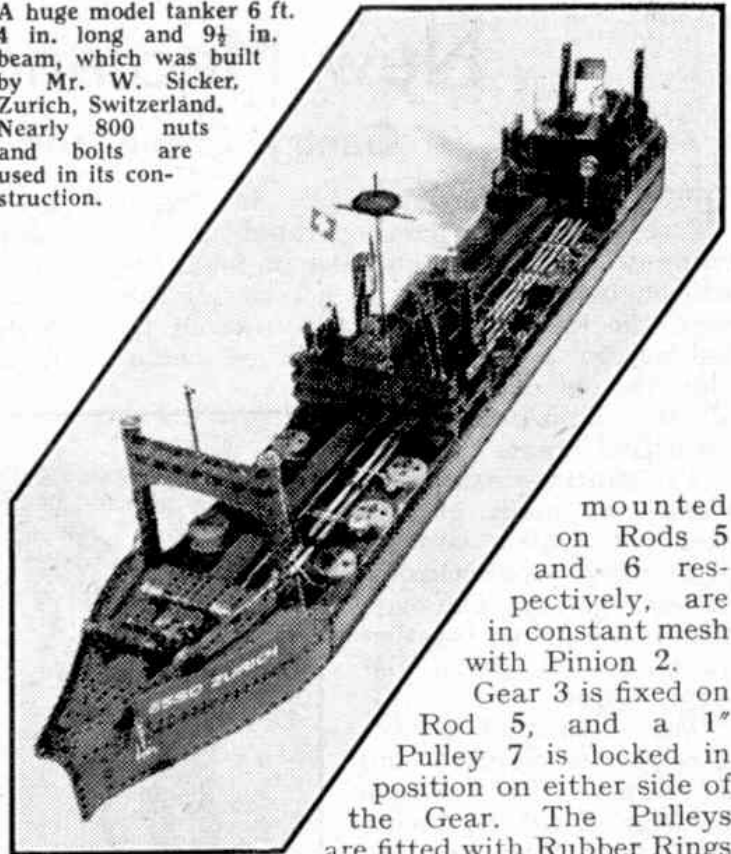

mounted on Rods 5 and 6 respectively, are in constant mesh with Pinion 2.

Gear 3 is fixed on Rod 5, and a 1" Pulley 7 is locked in position on either side of the Gear. The Pulleys are fitted with Rubber Rings

that form the friction surfaces between the winding drums. Each drum is made from a Bush Wheel and a 1½" Pulley connected by four ¾" Bolts, and they are loosely mounted on Rod 5. The drive is engaged by sliding Rod 5 so that one of the 1" Pulleys is pressed against its winding drum. The sliding movement of the Rod is controlled by a Crank 8 fitted with a Threaded Pin that engages between Collars on the end of the Rod. Crank 8 is fixed on a Rod mounted in a 4½" x ½" Double Angle Strip bolted to the housing, and it is controlled by a lever.

The brake on each drum consists of a length of Cord tied at one end to the housing and passed round the 1½" Pulley. It is then attached to a Crank 9 that can be connected to a spring-loaded foot pedal or lever.

The third movement is obtained by pressing Gear 4, free to turn on Rod 6, against a 1" Pulley 10 fitted with a Rubber Ring. The 1" Pulley is fixed on the Rod. The movement of Gear 4 is controlled by a Crank 11 on Rod 12 fitted with a Threaded Pin that engages the boss of the Gear.

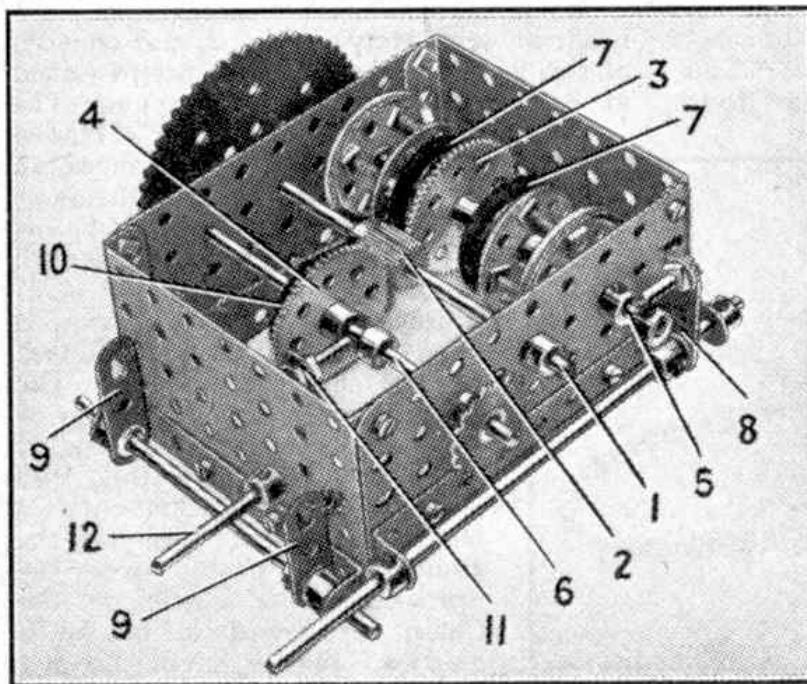

Fig. 2. -A useful constant mesh gear-box for model cranes.

# New Meccano Models

## Gantry Crane and Ball Game

THE sturdy model shown in Fig. 1 represents a hand-operated gantry crane of the kind often used in foundries and engineering shops. In a crane of this type the load is hoisted and lowered by pulling on an endless length of chain, and the model includes all the main features of an actual crane.

The gantry is assembled from two main girders, each of which consists of two  $18\frac{1}{2}$ " Angle Girders bolted together. The main girders are joined together at each end by a  $3\frac{1}{2}$ " Angle Girder.

The assembled gantry is supported at each end by four  $12\frac{1}{2}$ " Angle Girders. These are bolted in pairs to form inverted triangles, the bases of which are bolted to the gantry as shown in Fig. 1. The lower ends of the Girders are bolted to a  $9\frac{1}{2}$ " Angle Girder 1, which is extended upward by a  $9\frac{1}{2}$ " Flat Girder 2. A further  $9\frac{1}{2}$ " Angle Girder 3 is attached to Girder 1 by Double Brackets, and the travelling wheels are fixed on  $1\frac{1}{2}$ " Rods mounted in Girders 1 and 3. The wheels are  $1\frac{1}{2}$ " Pulleys, and the Rods

are held in position by Collars. The legs supporting the gantry are braced by  $5\frac{1}{2}$ " and  $3\frac{1}{2}$ " Strips as shown.

The hoisting mechanism is carried in a small trolley that is arranged to travel to and fro along the gantry. This trolley

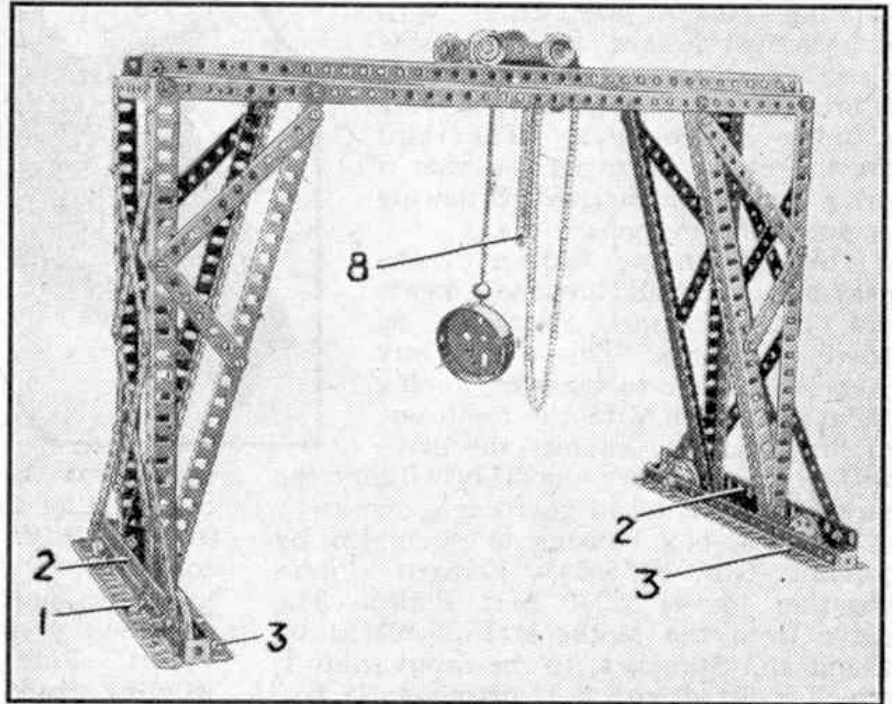

Fig. 1. A manually operated travelling gantry and traversing hoist that forms an interesting subject for a simple model.

is shown separately in Fig. 2, and consists of two  $2\frac{1}{2}$ "  $\times$   $\frac{1}{2}$ " Double Angle Strips joined at each end by a Flat Trunnion. The trolley runs on four  $\frac{3}{4}$ " Flanged Wheels fixed to 3" Rods mounted in the Double Angle Strips.

The hoisting movement is controlled by an endless length of Chain passed round a 2" Sprocket 4. This Sprocket is fixed on a  $3\frac{1}{2}$ " Rod 6 mounted in the Flat Trunnions. The Rod carries also a Worm 5 that meshes with a  $\frac{1}{2}$ " Pinion on a  $2\frac{1}{2}$ " Rod. On this Rod is also a 1" Sprocket, and a length of Chain tied to the trolley at 7 passes over the Sprocket. The slack of the Chain is allowed to fall in a loop 8, and a small Loaded Hook is tied to the free end of the Chain.

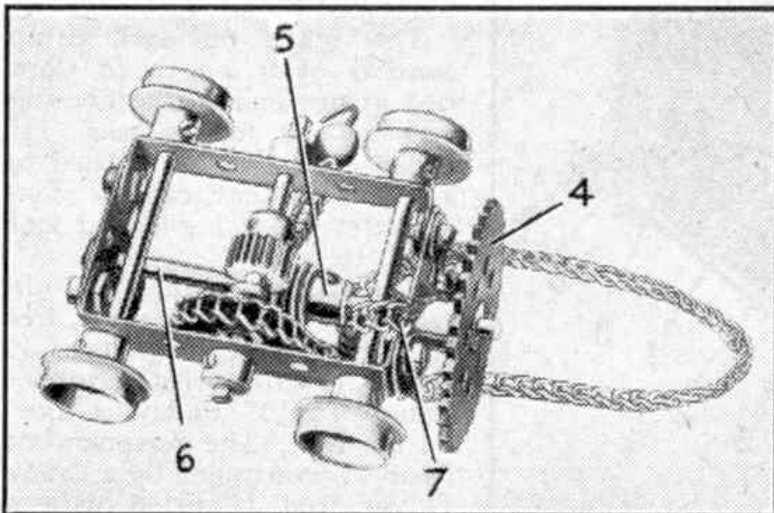

Fig. 2. The traversing hoisting trolley showing the arrangement of the gearing and chain.

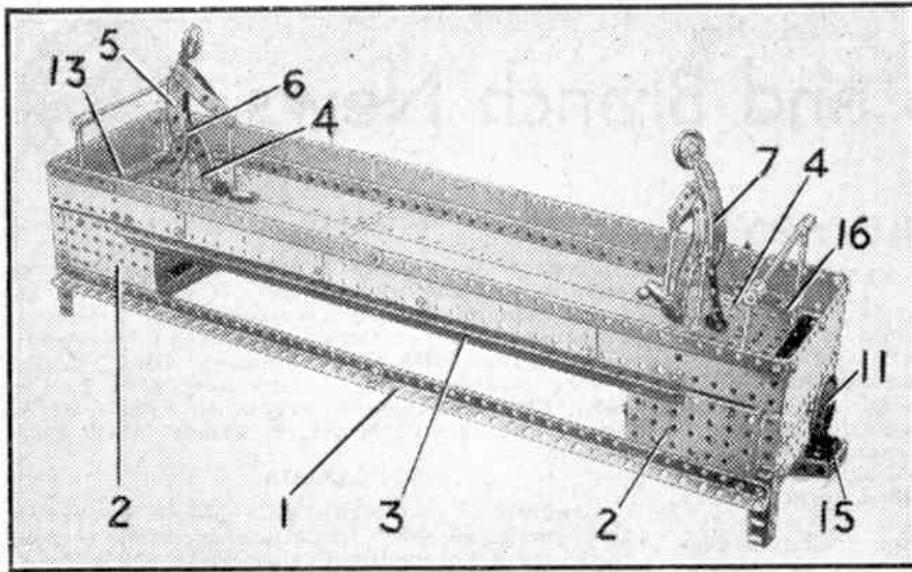

Fig. 3. Much good fun can be had from this easy-to-build mechanical ball game.

Parts required to build model Travelling Gantry Crane: 12 of No. 2; 4 of No. 2a; 4 of No. 3; 4 of No. 7a; 8 of No. 8; 4 of No. 8a; 4 of No. 11; 4 of No. 18a; 4 of No. 20b; 4 of No. 21; 1 of No. 26; 1 of No. 32; 59 of No. 37; 13 of No. 38; 2 of No. 48a; 2 of No. 48b; 1 of No. 57c; 11 of No. 59; 1 of No. 94; 1 of No. 95; 1 of No. 96; 2 of No. 103a; 2 of No. 126a; 1 of No. 162a.

Our next model, shown in Figs. 3 and 4, is a mechanical ball game based on the game of hockey. It is designed for two players, and consists of two pivoted figures mounted in front of goalposts and each provided with a hockey stick. The figures are so arranged that by turning a handwheel at each end of the model, they can be actuated and made to strike a Metal Ball. Each player tries to strike the Ball so as to direct it past the opposing player's goalkeeper and so score a goal.

Construction is begun by bolting a  $5\frac{1}{2}'' \times 2\frac{1}{2}''$  Flanged Plate and two  $2\frac{1}{2}''$  Angle Girders to the ends of the compound girders 1, which consist of two  $12\frac{1}{2}''$  Angle Girders overlapped two holes. Two  $3\frac{1}{2}'' \times 2\frac{1}{2}''$  Flanged Plates 2 are bolted to the sides, and these are connected by  $18\frac{1}{2}''$  Angle Girders 3. The  $5\frac{1}{2}'' \times 3\frac{1}{2}''$  Flat Plates 4 at each end of the model are attached to the sides by  $3''$  Angle Girders, and are arranged so as to leave a space in front of the  $5\frac{1}{2}'' \times 2\frac{1}{2}''$  Flanged Plate. The remainder of the floor of the table consists of three  $12\frac{1}{2}''$  Strip Plates and three  $5\frac{1}{2}'' \times 2\frac{1}{2}''$

Flexible Plates. The sides of the table are  $5\frac{1}{2}'' \times 1\frac{1}{2}''$  Flexible Plates and are attached to an  $18\frac{1}{2}''$  Angle Girder which is bolted to Girder 3. The ends are enclosed by  $5\frac{1}{2}'' \times 2\frac{1}{2}''$  Flexible Plates fixed to the side plates by Angle Brackets and bolted to the  $5\frac{1}{2}'' \times 2\frac{1}{2}''$  Flanged Plates.

The figures of the two goalkeepers are identical in construction and are built up as follows. Two  $2\frac{1}{2}''$  Curved Strips 5 forming the body and two  $2\frac{1}{2}''$  Strips representing the arms are bolted to a Double Bracket. At their other ends the  $2\frac{1}{2}''$  Curved Strips, together with two similar parts forming the legs, are attached to a Collar 6 by a bolt that carries two Washers on its shank. A Rod and Strip Connector is bolted between the Strips forming the arms and in this is fixed a  $2\frac{1}{2}''$  Rod fitted with a Coupling which represents the hockey stick. The head is a  $1''$  loose Pulley, and is attached by an Obtuse Angle Bracket, to a Formed Slotted Strip 7, which is bolted to the Double Bracket forming the shoulders. A  $4''$  Rod is held in Collar 6, and passed through Plate 4 and through a Double Bent Strip 8 bolted beneath the Plate 4. The Rod carries at its lower end a  $\frac{1}{2}''$  Pinion that engages a  $1\frac{1}{2}''$  Contrate Wheel 9. The Contrate is fixed on a  $5''$  Rod, bearings for which are provided by a  $5\frac{1}{2}''$  Strip 10 and (Continued on page 572)

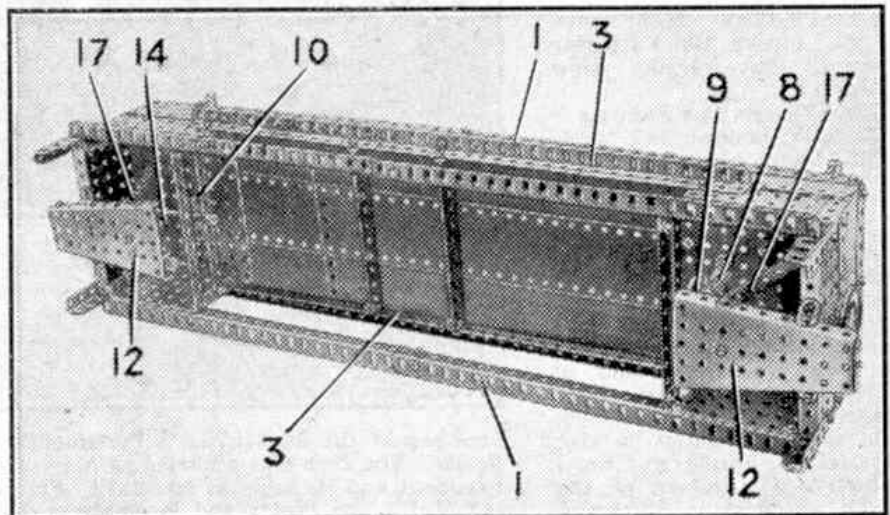

Fig. 4. An underneath view of the ball game.