

CARRY A LOAD—by Spanner

AS several readers have recently pointed out, it's been quite some time since we featured a model that can be built with standard Meccano Outfit No. 6. It's also some time since we featured a straightforward lorry so, this month, I thought I would kill two birds with one stone by including the fairly large lorry described below. Outfit No. 6 contains all the parts needed to build it.

CHASSIS AND STEERING

A strong but simple chassis is provided by two 12½ in. Angle Girders 1, each extended 12 holes by a 12½ in. Strip 2. At the front, Girders 1 are connected by a Semi-circular plate 3 while, at the rear, Strips 2 are joined by a 2½ in. by ½ in. Double Angle Strip 4. Also bolted between Girders 1, through their ninth holes, is a 2½ in. Strip 5. Flat Trunnions 6 are fixed to Strips 2 to provide bearings for a 5 in. Rod 7, held in place by 1 in. Fixed Pulleys. Mounted on the ends of this Rod are 2½ in. Road Wheels, as shown.

Secured to Angle Girders 1 through their fourth holes, is a 2½ in. by ½ in. Double Angle Strip, to which is bolted a 4½ in. compound strip 8, obtained from two 2½ in. Strips. Two similar arrangements are each provided by securing a 1½ in. Strip 9 between the lugs of a Double Bracket, using a Nut and a ⅜ in. Bolt, then the complete units are lock-nutted to the ends of compound strip 8. Another 4½ in. compound strip 10 is built up from two 2½ in. Strips and is lock-nutted between the ends of 1½ in. Strips 9, at the same time lock-nutting a 3½ in. Strip 11 to the nearside 1½ in. Strip. The other end of this Strip is, in turn, lock-nutted to an eight-hole Bush Wheel 12, which will later be mounted on the lower end

of the steering column. A 1½ in. Rod, carrying a 2½ in. Road Wheel and a Collar is journalled in the lugs of each Double Bracket.

CAB AND BONNET

In the case of the bonnet and driving cab, it is possible to build the entire unit separately, mounting it on the chassis when completed, and I suggest that this is what you do. Each side is composed of a 4½ in. by 2½ in. Flat Plate 13 extended by a 2½ in. by 2½ in. Flexible Plate 14. This latter Plate is edged along the lower side by a 3 in. Strip 15, one end of which is bolted to a 5½ in. Strip 16. At the top, Plate 14 is connected to Strip 16 by a Fish Plate. Note that Strip 16 protrudes three holes below the lower edge of the Plate.

The back of the cab is formed by a compound 4½ in. by 3½ in. Flexible Plate 17 built up from a 4½ in. by 2½ in. and two 2½ in. by 1½ in. Flexible Plates. It is fixed to the sides by Angle Brackets and by a 3½ in. by ½ in. Double Angle Strip 18, the Bolts securing this Double Angle Strip also holding the roof—a 3½ in. by 2½ in. Flanged Plate—in position. 2½ in. Strips 19 act as the forward roof stays. A bonnet top is obtained from a 4½ in. by 2½ in. Flexible Plate 20, extended by a Semi-circular Plate 21 and edged by two 3½ in. Strips 22 joined by another 3½ in. Strip 23. The completed unit is secured in place by Angle Brackets while Semi-circular Plate 21 is joined to Semi-circular Plate 3 by a 2½ in. by ½ in. Double Angle Strip 24. Three Formed Slotted Strips 25 are bolted to this Double Angle Strip to represent the radiator grille.

Each combined mudguard and running board is built up from a 2½ in. by 1½ in. Triangular Flexible

Plate 26 bolted to a 5½ in. by 1½ in. Flexible Plate 27 at the same time fixing a 1½ in. by ½ in. Double Angle Strip 28 in place. At its other end, Plate 27 is extended by a 2½ in. by 1½ in. Flexible Plate 29, attached to Plate 27 by Obtuse Angle Brackets. The finished arrangement is attached to the body by an Angle Bracket at the rear and by Double Angle Strip 28 at the front. A 4 in. Rod, journalled in Strip 5 and a Fishplate bolted to Strip 23, serves as the steering column, which is held in place by a Collar 30. Bush Wheel 12 is fixed on the lower end of the Rod while an eight-hole Bush Wheel 31 is secured on the upper end of the Rod to represent the steering wheel. Angle Brackets, incidentally, are used to fix the back and sides of the cab to the chassis.

LOAD BODY

Perhaps the most interesting aspect of the actual load carrying section of the model is the way Strips have been extensively used in its construction to provide greater strength and rigidity. Each side, in fact, is composed of four 12½ in. Strips 32, joined together and to a 12½ in. Angle Girder 33 by three 2½ in. Strips 34, at the same time securing a 5½ in. by 2½ in. Flanged Plate 35 between the sides to form the forward end. The back is represented by a 5½ in. by 2½ in. Flexible Plate 36, overlaid by two 5½ in. Strips 37 and attached to the sides by two 1 in. by 1 in. Angle Brackets and two ½ in. by ½ in. Angle Brackets.

The floor or 'bed' of the load body is provided by two 12½ in. by 2½ in. Strip Plates 38 separated by a 12½ in. Strip 39. All are joined by three lateral 5½ in. Strips 40, placed one at each end and one in the centre. The whole unit is bolted to Angle Girders 33 and Flanged Plate 35. When finished the com-

plete load body is attached to the chassis by two Double Brackets at the front and two ½ in. by ½ in. Reversed Angle Brackets at the rear. Finally, a front bumper is provided by two shaped 5½ in. Strips 41, overlapped nine holes and joined to Angle Girders 1 by two 2½ in. by ½ in. Double Angle Strips 42.

This completes the model as illustrated here, but several improvements can be made. For example, the windows could be glazed with Transparent Plastic Plates. The reason why we did not fit glazing was to allow access to the steering wheel which does, of course, operate. Another modification which springs to mind is the fitting of additional body and chassis details such as headlamps, sidelamps, exhaust pipe, etc. There are any number of things that could be included, really, provided you have the spare parts available.

Something that I always advise builders to attempt, where possible, is the motorising of any suitable basic model we feature. I'm not sure how it could be done in this case, but I have no doubt that it would be possible even if it meant completely restyling the bed of the load body. Have a try, anyway!

PARTS REQUIRED

11 of No. 1	2 of No. 18a	5 of No. 111c
9 of No. 2	2 of No. 22	2 of No. 125
4 of No. 3	2 of No. 24	2 of No. 126a
2 of No. 4	146 of No. 37a	4 of No. 187
13 of No. 5	135 of No. 37b	4 of No. 188
2 of No. 6a	16 of No. 38	2 of No. 189
4 of No. 8	2 of No. 48	2 of No. 190
3 of No. 10 ¹	5 of No. 48a	2 of No. 191
4 of No. 11	1 of No. 48b	1 of No. 192
26 of No. 12	1 of No. 52	2 of No. 197
2 of No. 12a	1 of No. 53	2 of No. 214
1 of No. 15	2 of No. 53a	3 of No. 215
1 of No. 15b	3 of No. 59	2 of No. 221

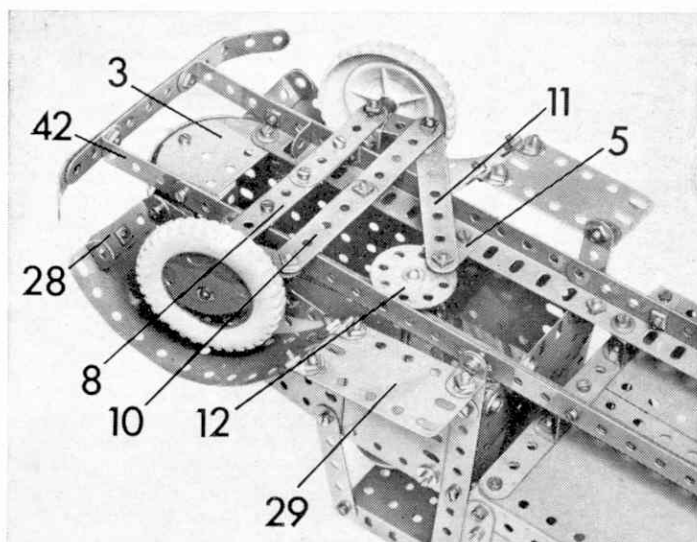
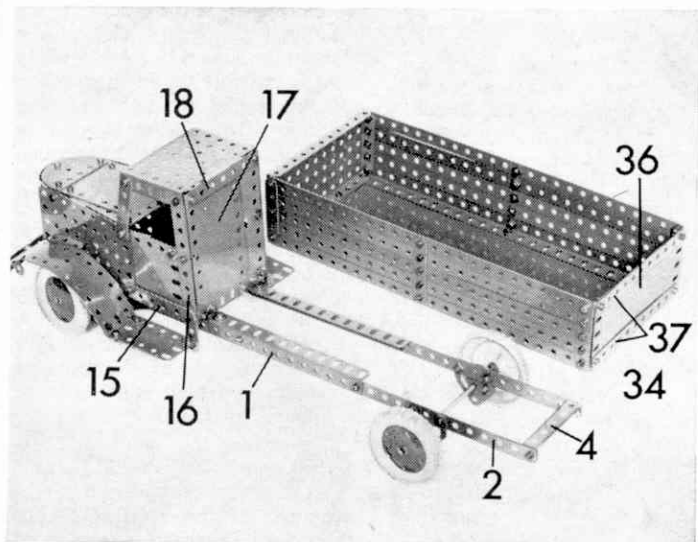

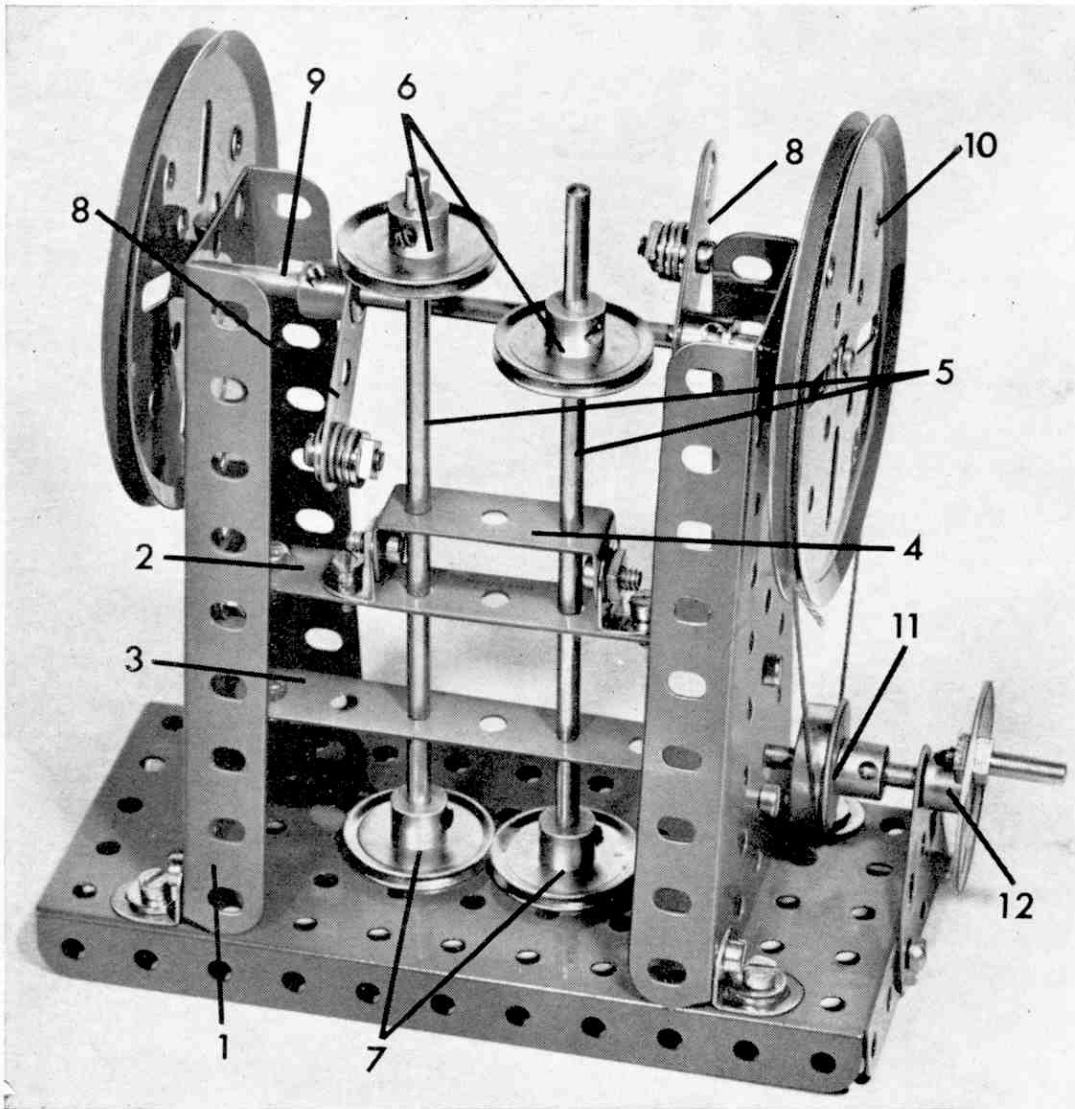

The 'Double Trip Hammer'. Both hammers are operated automatically when the handle at the side is turned. Two tappets convert this rotary motion of the handle into the 'up and down' motion of the hammers

Pulleys 11, spaced from the Flat Trunnions by Washers. Fixed in the centre of the Rod are two $\frac{1}{4}$ in. Flanged Wheels 12, which will later provide the drum for a simple but very effective brake. The steering column is represented by a second $3\frac{1}{2}$ in. Rod 13, journalled in outside Strip 1 and a 1 in. by 1 in. Angle Bracket 14, bolted to corresponding Double Angle Strip 5. A Spring Clip beneath this Angle Bracket and a $\frac{1}{4}$ in. Flanged Wheel above hold the Rod in place. A $\frac{1}{4}$ in. Bolt is fixed in the boss of the Flanged Wheel to act as the actual steering handle, while a 1 in. by $\frac{1}{2}$ in. Angle Bracket 15 is bolted to the underside of Flanged Plate 2, immediately forward of the off-side Flat Trunnion 10. An 'endless' length of Cord is then passed through the end hole in this Angle Bracket, is wrapped completely round a 1 in. Pulley 16 fixed to the lower end of Rod 13, and is finally attached to Double Angle Strip 7 through its nearside hole.

It now needs only the earlier-mentioned brake to complete the model. Two Double Brackets 17 are bolted to the arm of a Crank, which is then fixed, along with another Crank 18, on a $3\frac{1}{2}$ in. Rod, held by Spring Clips in a $2\frac{1}{2}$ in. by $\frac{1}{2}$ in. Double Angle Strip 19 bolted to the front flange of Plate 2. A length of Cord is then attached to Crank 18 through its centre hole, is passed through the hole in the free lug of Angle Bracket 5, is threaded through the centre hole in Double Angle Strip 19, is wrapped several times around Flange Wheels 12 and is tied to the Double Bent Strip bolted to the underside of Flanged Plate 2.

PARTS REQUIRED

3 of No. 5	5 of No. 22	7 of No. 48a
1 of No. 6a	1 of No. 23	1 of No. 52
2 of No. 11	3 of No. 35	2 of No. 62
1 of No. 12	29 of No. 37a	1 of No. 111
1 of No. 12a	27 of No. 37b	1 of No. 111a
1 of No. 12b	5 of No. 38	2 of No. 126a
3 of No. 16	1 of No. 40	2 of No. 155
1 of No. 17	1 of No. 45	
3 of No. 20b	1 of No. 48	

**THEY
ARE
NOT
NEW
SPANNER**

ILLUSTRATED here you will find three small Meccano models. They're not new, but I haven't seen them before and I doubt if any of today's readers have either—I found them described in a 1928 issue of Meccano Magazine! I should explain that, when I have a bit of spare time, I like to browse through the volumes of early Magazines that I have in the office, not only because they contain all sorts of interesting articles, but also because they feature an enormous number of Meccano models. The three constructions described below are just three examples that caught my eye and which I thought present-day builders would like to see.

ELECTRIC TRUCK

First of the three was described quite simply as an 'Electric Truck', and was claimed to be, 'a realistic reproduction of a type of electrically-operated truck used in railway stations, factories, etc., for the expeditious handling of luggage or materials'. I found it very easy to build, although I did take the liberty of making one or two small alterations. Three $2\frac{1}{2}$ in. Strips 1 are

bolted to a $5\frac{1}{2}$ in. by $2\frac{1}{2}$ in. Flanged Plate 2, to extend three holes, after which they are joined by a $1\frac{1}{2}$ in. Strip 3, at the same time securing a $\frac{1}{2}$ in. by $\frac{1}{2}$ in. Angle Bracket 4 in position. Five $2\frac{1}{2}$ in. by $\frac{1}{2}$ in. Double Angle Strips 5 are then fixed to the top of the Flanged Plate, three above Strips 1 and the remaining two each spaced from the Plate by a Washer on the shank of the fixing Bolt. Another $2\frac{1}{2}$ in. by $\frac{1}{2}$ in. Double Angle Strip 6 is bolted between Double Angle Strips 5 to brace them.

At this stage the wheels should be added. Bolted to the underside of Flanged Plate 2 is a Double Bent Strip, to which a $1\frac{1}{2}$ in. by $\frac{1}{2}$ in. Double Angle Strip 7 is fixed by a lock-nutted $\frac{1}{2}$ in. Bolt, a $\frac{1}{2}$ in. loose Pulley 8 being used as a spacer between the Angle Strip and the Bent Strip. A 2 in. Rod 9 is journalled in the lugs of the Double Angle Strips and is held in place by 1 in. Fixed Pulleys with Rubber Rings.

Two Flat Trunnions 10 are now bolted to the side flanges of Plate 2, to provide bearings for a $3\frac{1}{2}$ in. Rod, also held in place by 1 in. Fixed

AUTOMATIC HAMMER

Equally correct today is the original description of our second 'old' model—'Double Trip Hammer'. As the name implies, it's a machine incorporating two hammers which are operated automatically by the action of a handle at the side. On a real machine, of course, the operation would be controlled by compressed air.

Construction, again, is very easy. Two Flanged Sector Plates 1, separated by a distance of seven holes, are secured to a $5\frac{1}{2}$ in. by $2\frac{1}{2}$ in. Flanged Plate by Angle Brackets. Fixed between the Sector Plates, also by Angle Brackets, are two $3\frac{1}{2}$ in. Strips 2 and 3, to the upper of which a $1\frac{1}{2}$ in. by $\frac{1}{2}$ in. Double Angle Strip 4 is attached, again by Angle Brackets. Two 5 in. Rods 5, each carrying two 1 in. Fixed Pulleys 6 and 7, are mounted in the end holes of this Double Angle Strip and in the corresponding holes of Strips 2 and 3. The Pulleys are fixed on the Rods in the positions shown in the accompanying illustration.

Pulleys 7, of course, represent the hammers which are lifted alternately by the action of two 'tappets' striking against Pulleys 6. Each tappet consists of a Crank 8, in the arm of which is fixed a $\frac{1}{8}$ in. Bolt, carrying a number of Washers on its shank. Note that the Bolt is fixed in the end hole of one Crank and in the centre hole of the other. The Cranks are mounted at 180 degrees to each other on a $4\frac{1}{2}$ in. Rod 9, journaled in the Sector Plates and held in place by two 3 in. Pulleys 10.

An operating handle is now built up from a 2 in. Rod, carrying a $\frac{1}{4}$ in. Flanged Wheel 11, which is mounted in one of the Sector Plates and in a Flat Trunnion bolted to the end flange of the Flanged Plate. A Collar and an eight-hole Bush Wheel 12 hold the Rod in position. Finally, a Threaded Pin is mounted in the face of the Bush Wheel and Flanged Wheel 11 is connected to corresponding Pulley 10 by a Cord driving band.

PARTS REQUIRED

2 of No. 3	4 of No. 22	1 of No. 52
10 of No. 12	1 of No. 24	1 of No. 54
2 of No. 15	24 of No. 37a	1 of No. 59
1 of No. 15a	22 of No. 37b	2 of No. 62
1 of No. 17	13 of No. 38	2 of No. 111c
2 of No. 19b	1 of No. 40	1 of No. 115
1 of No. 20b	1 of No. 48	1 of No. 126a

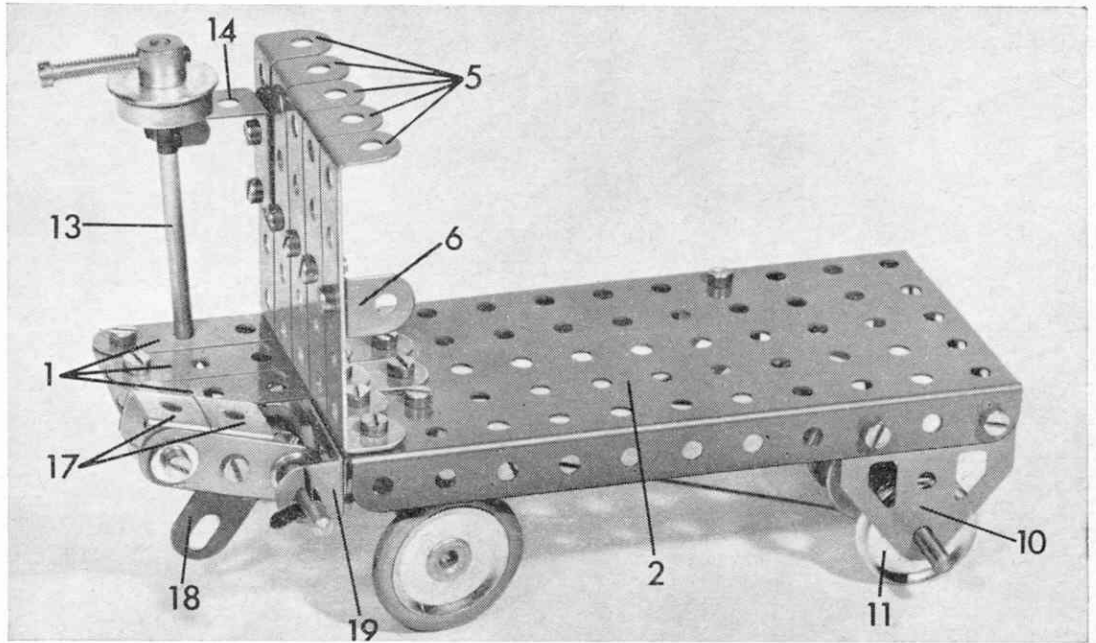

Although it is a very simple model, the Electric Truck is an excellent reproduction of a vehicle still commonly seen on railway stations everywhere

SOAP BOX CART?

Third and final model was called, quite simply, a 'Meccano Coaster', because it was 'a type of vehicle intended principally for travelling down-hill by the force of gravity'. Whatever it was called, however, it still looks to me like a sophisticated version of a child's soap box cart. To build it, a $5\frac{1}{2}$ in. by $2\frac{1}{2}$ in. Flanged Plate 1 is extended forward four holes by two $5\frac{1}{2}$ in. Strips 2, which are then connected by a $2\frac{1}{2}$ in. by $2\frac{1}{2}$ in. Double Angle Strip 3, lugs uppermost. Another $2\frac{1}{2}$ in. by $\frac{1}{2}$ in. Double Angle Strip 4 is fixed to the lugs of this Double Angle Strip to provide bearings for the steering column, a $1\frac{1}{2}$ in. Rod carrying a 1 in. Fixed Pulley 5 at the top and an eight-hole Bush Wheel 6 at the lower end.

Bolted to the Bush Wheel is a third $2\frac{1}{2}$ in. by $\frac{1}{2}$ in. Double Angle Strip 7, in which a $4\frac{1}{2}$ in. Rod is held by Spring Clips. Mounted on the ends of this Rod are $2\frac{1}{2}$ in. Road Wheels, while a further two $2\frac{1}{2}$ in. Road Wheels 8 are mounted on a $3\frac{1}{2}$ in. Rod, journaled in Flat Trunnions fixed to the other end of the Flanged Plate. Steering handles are provided by two $2\frac{1}{2}$ in. Strips 9, lock-nutted to the side flanges of Plate 1 and connected to Double Angle Strip 7 by lengths of Cord. Bolts fixed by two Nuts in the flanges of Plate 1 act as 'stops' for the steering handles. Lastly, a seat is represented by a fourth $2\frac{1}{2}$ in. by $\frac{1}{2}$ in. Double Angle Strip, attached to the Flanged Plate by Fishplates.

PARTS REQUIRED

2 of No. 2	1 of No. 22	1 of No. 40
2 of No. 5	1 of No. 24	4 of No. 48a
2 of No. 10	2 of No. 35	1 of No. 52
1 of No. 5a	26 of No. 37a	4 of No. 107
1 of No. 16	22 of No. 37b	
1 of No. 18a	4 of No. 38	

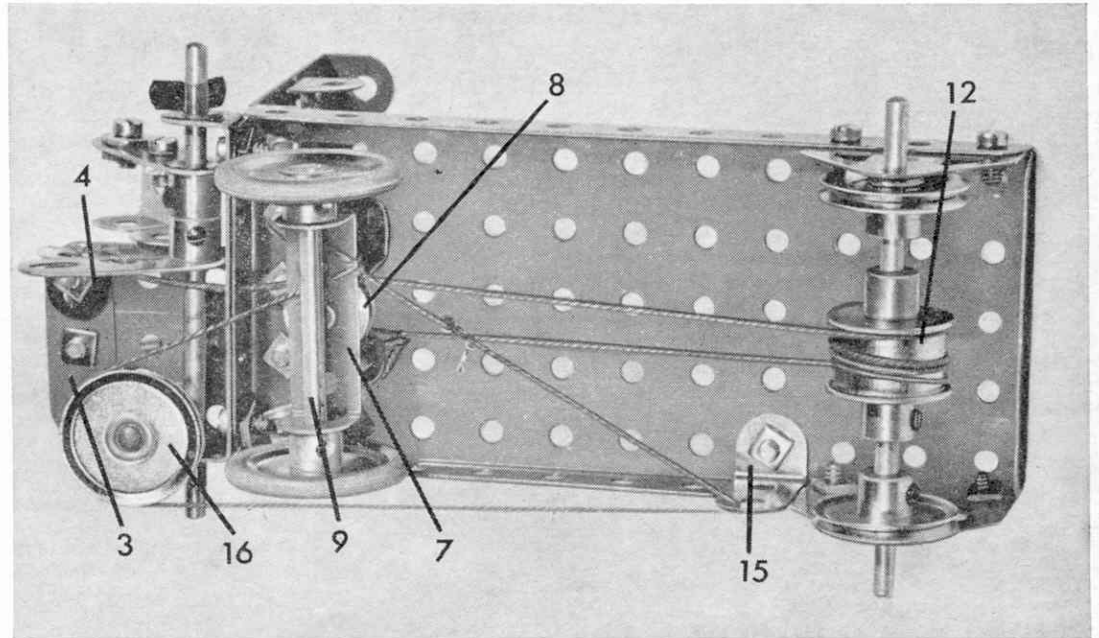

Underside of the truck, showing the ingenious steering and braking systems. Below: the 'Meccano Coaster' is steered by two levers instead of a conventional wheel—an interesting vehicle to drive, no doubt

