

fig.2

Meccano Constructors Guide

by B. N. Love

Reconstruction of original Meccano Motor Chassis which demonstrates basic car mechanics.

PART 10 – VEHICLE MECHANICS

ANY LAD OPENING his Meccano Outfit for the first time will be confronted with a range of parts so suggestive of vehicles that some form of car or lorry will be among the very first of his creations.

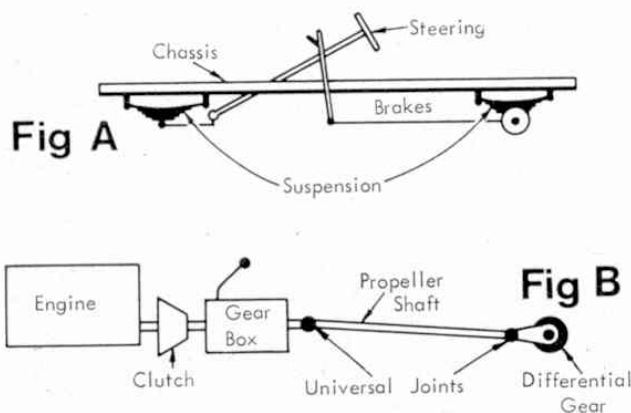

This fever seldom leaves the life-long enthusiast who knows how well the system is suited for demonstrating vehicle mechanics. If we consider two aspects of this topic we might put them in these categories:

(a) Chassis, steering, brakes and suspension, and (b) Transmission from engine to road wheels.

Although the bareness of the diagrams make them more akin to a 1916 Motor omnibus than a 1970 family saloon, the essentials have altered little in the past fifty years. In other words, we need basically, four wheels attached to a frame and a method of propelling the vehicle smoothly and a means for setting it in motion and bringing it to rest while being able to make it follow a non linear path. Considering the chassis before the transmission is literally putting the cart before the horse so we might consider the latter first. Thanks to the Powerdrive motor with its built-in gear box we can install an engine in a Meccano model in a comparatively small space and then proceed to give it realism by building detail around it. At one time the constructor was obliged to use a long sideplate motor which can be seen installed in the original Meccano Motor Chassis, a rebuild of which appears in Fig. 2. Despite the limitation in parts of the period from which this model originates, the basic movements of the motor mechanisms are all reproduced in this model.

Fig. 3 shows what can be done in the way of disguising the Powerdrive motor of modern manufacture by enclosing it in an engine 'block' constructed of Plates, Strips and accessory parts to simulate a heavy duty deisel unit. Fuel lines are easily assembled from connecting wire covered in transparent plastic insulation while standard parts provide generator, breather, dipstick and well, starter motor and cooling fan. A clutch housing is provided by a Boiler End, four 1 in. \times $\frac{1}{2}$ in. Angle Brackets and an 8-hole disc to form the Bell moulding, while particular care has been taken in making the thrust race which is engaged by the clutch dogs to disengage the clutch plate. The two $\frac{3}{4}$ in. Washers sandwiching a 'spider' Collar (Part No. 140Y) which carries four Washers on short Set Screws forms probably the smallest Meccano Roller Bearing. It is very efficient in action.

This particular clutch is somewhat unorthodox in that the Bell housing revolves as a whole, the clutch plate being a 1 in. Pulley with Motor Tyre fixed to the engine shaft. When the clutch pedal is depressed, the Bell housing moves forward bodily, the Boiler End component thus losing contact with the Motor Tyre carried inside it. The clutch shaft is fitted with a Small electrical Bush Wheel at its rear end to engage with a sliding coupling to the gearbox and its forward

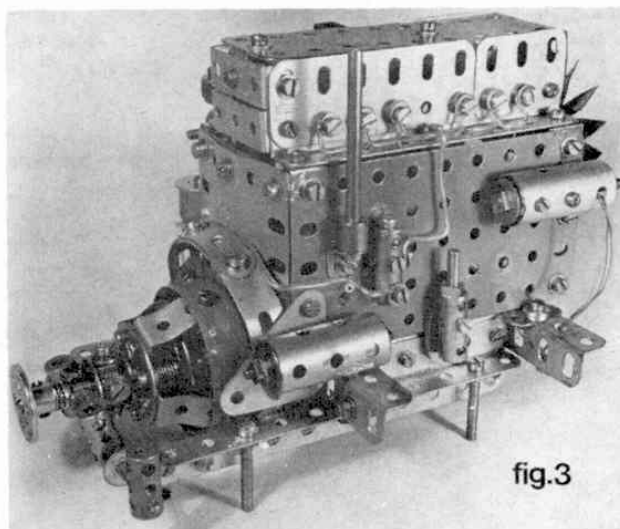

Built up engine block housing Powerdrive Unit.

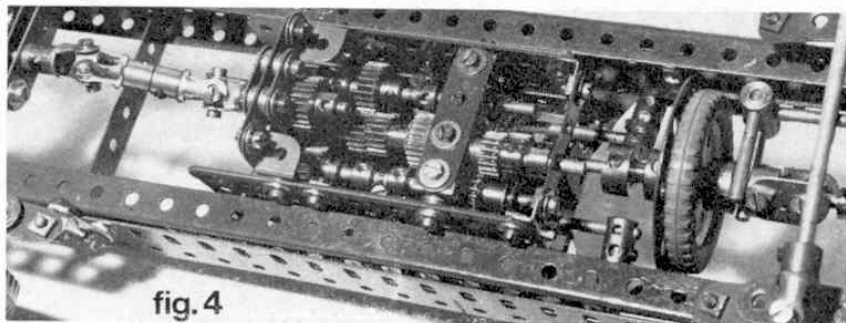

Simple clutch unit on lorry chassis. Note all-Pinion gear-box and universal coupling at rear.

fig.4

end carries the spring pressure 8-hole disc and Bush Wheel, a portion of this shaft being journalled in the clutch housing in alignment with the engine shaft. The inner 8-hole disc is spaced from its Bush Wheel by a lock-nut on each of the compression spring bolts and

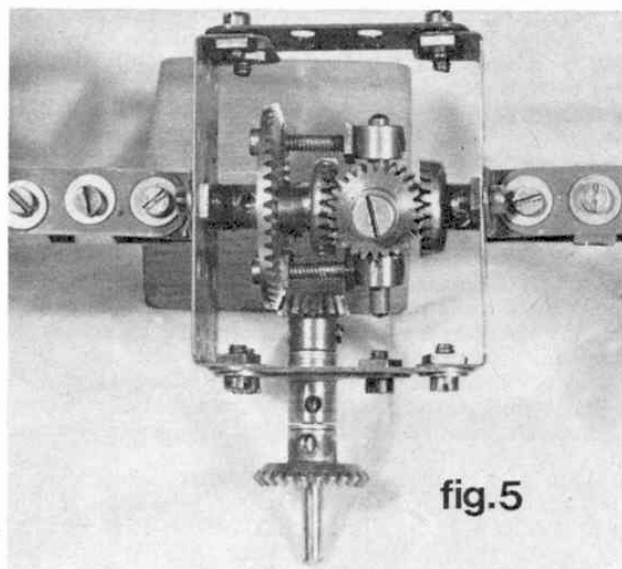

Simple differential gear employing Bevel, Contrate and Pinion Gears.

fig.5

thus forms a free centre for the tip of the engine shaft to enter for alignment. A pressure pad of greased washers may be inserted between this inner disc and the boss of the 1 in. Pulley with Tyre for clutch idling with motor running.

A simpler but perfectly effective clutch unit is shown in Fig. 4. In this case, the clutch plate is a Faceplate connected to the gearbox shaft by a Socket Coupling

and Collar. This provides a hollow bearing through the centre of the Faceplate boss so that the engine shaft can be journalled inside it. The clutch friction disc is a Motor Tyre on a 1½ in. Pulley journalled in a second Socket Coupling which is free to slide on the engine shaft. It is obliged to revolve with the engine shaft by the drive from a pair of Fishplates lock-nutted to the other end of the Socket Coupling as shown in the illustration. The slotted holes of the Fishplates slide on the shanks of Set Screws fixed tightly in a Collar on the engine shaft. A clutch fork is made from two 1½ in. Axle Rods in a Coupling attached to the clutch pedal by link rods. This fork will pull the 1½ in. Pulley with Tyre away from the Faceplate when the clutch pedal is pressed to disengage.

Fig. 4 also shows a compact gearbox based on a non-standard spacing employing ½ in. and ¾ in. Pinions. Twin lay-shafts are employed in this arrangement because of the limited selection of Pinion sizes. The central shaft is split at the centre in a common bearing and three forward speeds plus one reverse are available. Readers are referred to M.M. for April 1969, page 192, for a further explanation of a similar gearbox. The non standard spacing of ½ in. and ¾ in. Pinions in mesh is achieved by using Flat Girders in the construction of the gearbox casing, exploiting the slotted holes to obtain the critical spacing required. Notice that at the output of the gearbox, a universal joint is provided. Fig. 1 shows the normal positions for these joints which are required to make allowance for the difference in level between the rear axle of the vehicle and its gearbox. This difference in level is both a design feature and a consequence of axle movement when the vehicle is travelling. A universal joint is capable of making a junction between the ends of two shafts in such a way that rotation is maintained even when the shafts are at a small angle to one another—drive being available for an angle up to 45 deg. but with decreasing efficiency as the angle increases.

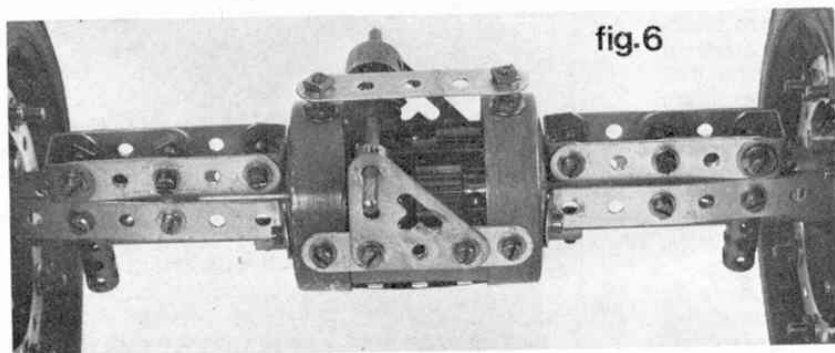

Heavy-duty rear axle unit with spur gear differential.

fig.6

Demonstration front axle drive with flexible joints to road wheels. Note use of Socket Couplings as axle bearings.

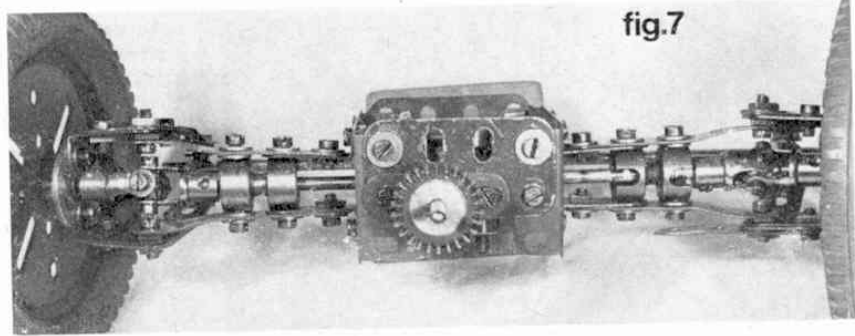

At this stage the transmission from the engine is still running in a line from front to rear and must be turned through 90 deg. if the rear axle is to turn. This could be achieved very simply by using a Pinion and Contrate gear to obtain the necessary right-angle drive as demonstrated in the early chapters of the Constructors' Guide and for very simple models this is a satisfactory way of doing the job. However, when a vehicle changes direction it tends to follow a curved path, as tyre marks in snow or mud will immediately show. This running over curved paths causes the rear wheels to run at different speeds depending on the sharpness of the turn and its direction left or right. Therefore, to permit the rear wheels to turn at different speeds, a differential drive is required and a simple form of this is shown in Fig. 5. Many such differentials have been illustrated in M.M. over its 50 years and more of publication and the gear illustrated in Fig. 5 is a neat combination of bevels, contrates and pinions. A Coupling forms the heart of the differential and receives the inner ends of the 'half-shafts' running to each road wheel, in either end of its lateral bore. The central transverse bore of the Coupling holds a $1\frac{1}{2}$ in. Axle Rod which in turn is bolted to the large Bevel Gear by $\frac{3}{4}$ in. Bolts lock-nutted on Collars as shown. The two 'planetary' 50-teeth Pinions are carried round in 'orbit' by the Pivot Bolts which tie them to the central tapped holes of the Coupling. The two 50-teeth Contrate Gears receive the drive from the Pinions and pass it on to their respective road wheels. If the vehicle is travelling in a straight line on a flat surface, both rear wheels will revolve at the same speed and the orbiting planet Pinions will be carried round by the large Bevel Gear, known as the 'crown' wheel, but the Pinions will not revolve on their Pivot Bolts. If, on turning a corner, one rear wheel is turning faster than the other, the planet Pinions will commence to turn on their bolts and in so doing will pass on a 'differential' motion to the two half-shafts comprising the rear axle. An appreciation of this is far more easily demonstrated by making up the mechanism than by attempting to describe its working in print.

An important feature in mounting differential gear-boxes on rear axles is to ensure that they are rigidly attached to axle tubes which are in turn secured to the springs of the vehicle. Fig. 6 shows a rugged construction of a differential gear case suitable for a heavy duty model lorry. Boiler Ends provide strong journal plates for the axle tubes and half-shafts which run out from the differential. By a suitable selection of Double Angle Strips, Double Brackets, etc., the reinforced rear axle assembly shown will carry considerable torque and is designed to receive hub reduction gear at its extremities. Under these conditions, a model would be reaching a very advanced state. The actual differential shown is known as a spur differential because spur or Pinion gears are used. The principles do not

change, however, long and short faced Pinions being employed to obtain the necessary meshing arrangements. In this particular instance, a Helical 'crown' wheel is employed to turn the differential carrier and this allows a top meshing Helical to pass the drive 'over the top' making it a simple matter to engage the drive to a second differential if twin rear axles are employed.

Fig. 7 shows a drive arrangement for a front axle where the road wheels are required to steer. Under prototype conditions a special flexible joint is required to pass on a steady drive to the front wheels at all angles of steering. The geometry of the simple universal joint shown in Fig. 7 falls short of this requirement, a special slot and ball joint being required. This can be partially simulated in the Meccano system by engaging a Handrail Coupling, fitted with a Keyway Bolt, in the open end of a Socket Coupling. This does not give a true ball joint through 360 deg. of drive however but the arrangement shown in the illustration is adequate for demonstration purposes. Note the use of Socket Couplings as rigid bearings in the axle tubes. Basic steering on non-driven front axles has been illustrated frequently in various Meccano articles and a further example is shown in Fig. 8. In

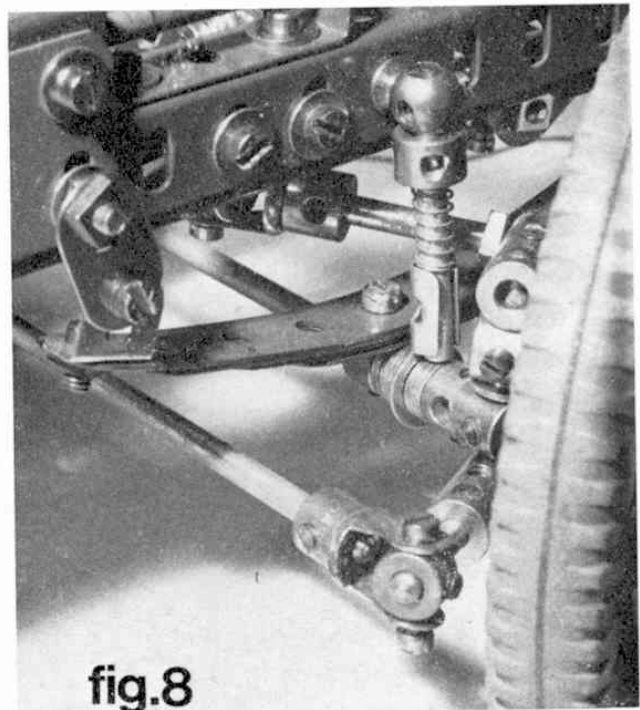

Steering gear fitted with simple coil spring shock absorber.

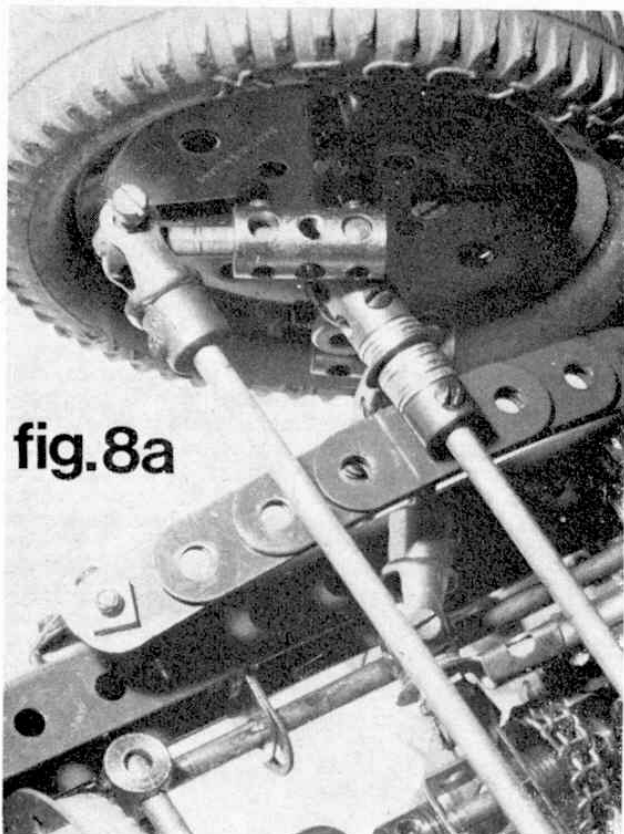

fig.8a

Arrangement of leaf springs and front axle rod securing collars to centre of springs.

this case an Axle Rod is used for the main axle beam which is secured to the leaf springs by Collars. Short Couplings at each end serve as Kingpin journals and the track rods which link one wheel hub to the other

Tipping section of heavy lorry for earth moving. Note curved shape under bodywork.

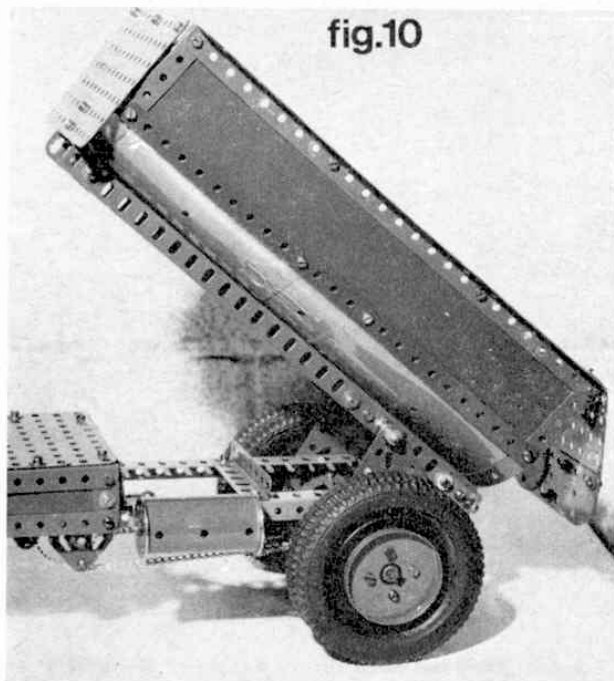

fig.10

are terminated in Swivel Bearings. An interesting feature in Fig. 8 is the provision of a coil spring shock absorber. A 1½ in. Axle Rod pivots in a Rod and Strip Connector on the main Axle and carries a Compression Spring held in place by a loose Collar. A handrail Support, lock-nutted to the chassis, allows the 1½ in. Axle Rod to ride up and down in its transverse bore to cushion the bumps from the main leaf springs.

A form of coil spring suspension is shown in Fig. 9 applied to a neat model of a veteran car. In this case the front axle beam is made of two or three thicknesses of Perforated Strips pivoted at the centre just below the bonnet. Cranks are bolted to each end of the beam to form journals for the Kingpins which are reinforced from below by a cross-strut made from further Perforated Strips. The chassis bearers on either side of the radiator are fitted with Long Threaded Pins pointing downwards, each fitted with two Compression Springs, the tips of the Pins penetrating the axle beam at which point the Compression Springs are trapped in place.

Vehicle features in general offer considerable scope to the Meccano modeller as the veteran car radiator details illustrate in Fig. 9. Coiled Tension Springs in this case give a very realistic appearance while the sharp bends in the Flexible Plates gives a really veteran look to the model.

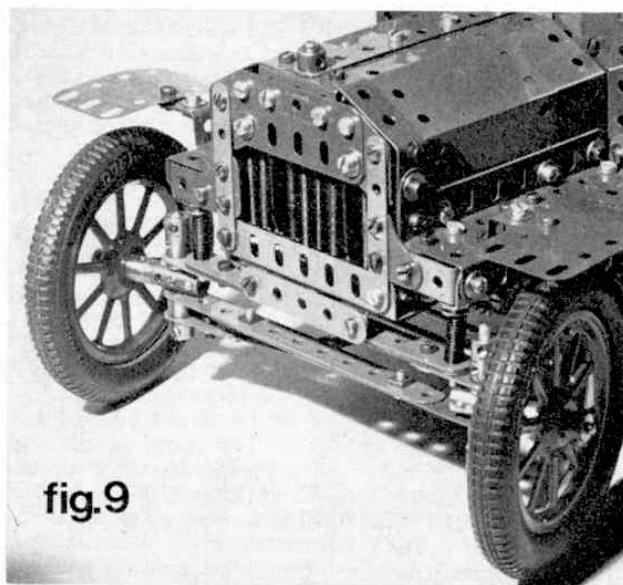

fig.9

Simple front axle unit for veteran car employing central axle pivot and coil spring suspension.

Commercial vehicles are always popular and with so much motorway construction in progress, the tipper is a common sight these days. Nothing spoils the appearance of such a model as a tipper section which is badly designed or full of holes and the example shown in Fig. 10, although quite simple, makes a neat job of tipping. This is largely due to the use of overlapping flexible plates to give a curved under-belly to the tip unit with a minimum number of protruding bolt shanks to prevent smooth discharge of spoil. A further feature is the gravity tail board, hinged from the top edge and neatly curved at its lower edge to conform to the tip-body contours. Twin rear wheels are fitted to the vehicle and nicely finished with Wheel Flanges. The tipping motion, which is controlled from the driver's seat is via the motor gearbox and Sprocket Chain.