

JANUARY 1925.

MECCANO

MAGAZINE

PRICE
3^D
VOL: X
NO.1.

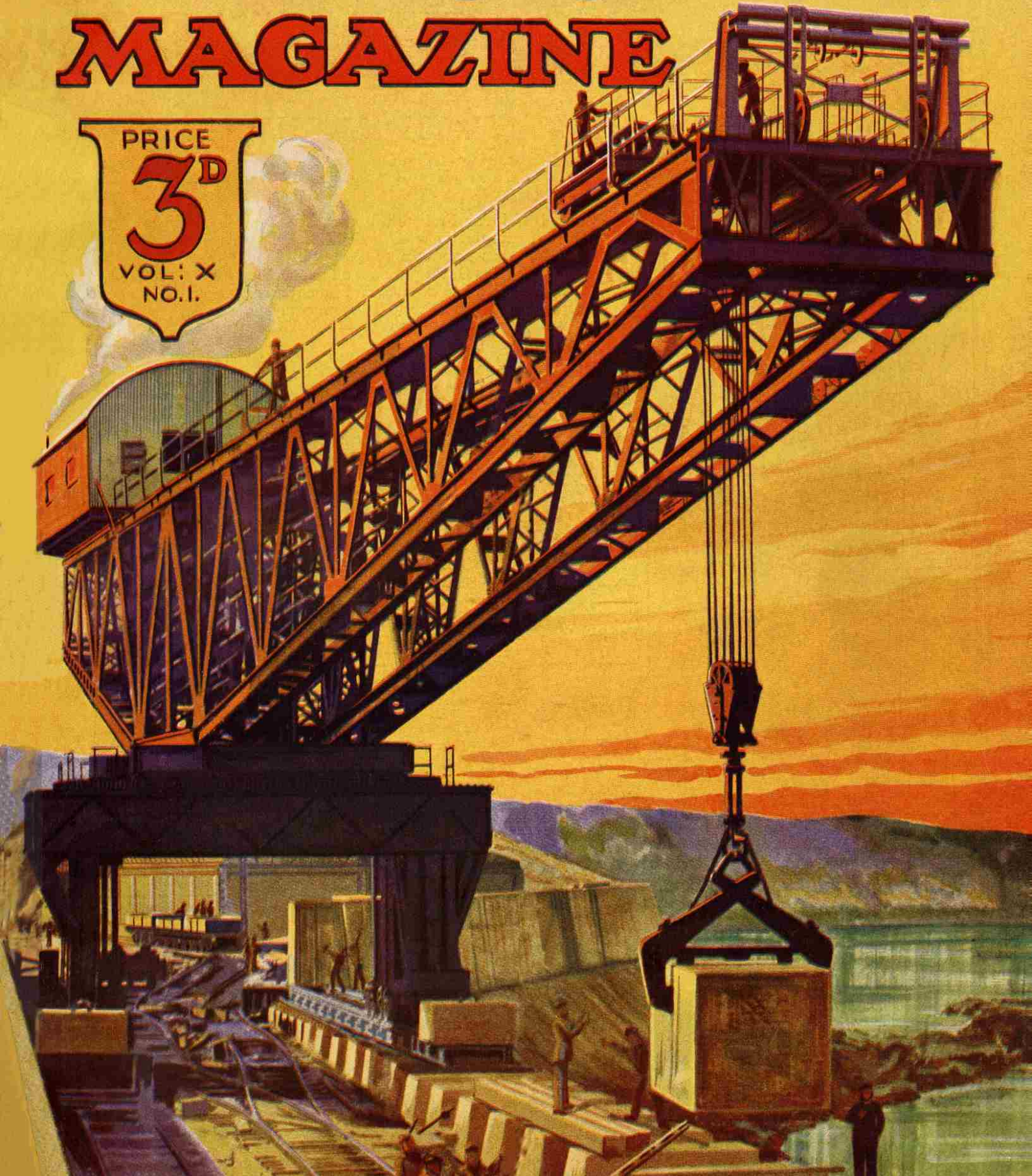

BE SURE THEY ARE BRITISH!

A FRETWORK OUTFIT WILL KEEP YOU HAPPY

Every boy loves Fretwork because he handles real tools and cuts out in wood articles of use in his own home. He has hundreds of things to choose from, and any Hobbies Outfit provides all the necessary tools. A start can be made at once and money easily earned after very little practice. It is fascinating, simple, and varied, and there is an Outfit to suit every purse.

But be sure to get a Hobbies Outfit—others contain cheap foreign tools which break and need replacing in a very short while. Hobbies goods are reliable as well as good-looking.

EVERY OUTFIT COMPLETE EVERY TOOL BRITISH

Outfit Prices

		Post Free		Post Free
No. 1½	4/-	4/6	No. 5½	13/6 14/3
No. 2	5/6	6/-	The A1	16/6 17/6
No. 2½	6/6	7/-	The A3	32/6 33/6
No. 3	8/-	8/9	The A4	23/6 24/6
No. 3½	9/6	10/3	The A6	27/6 28/6
No. 3½	12/-	12/9	Cabinet	57/6 59/-

FREE Every week there are free designs for useful articles anyone can make, as well as **DESIGNS** helpful hints on a number of subjects of interest to any Meccano Boy. Photography, Stripwork, Philately, Carpentry, etc., are all dealt with.

SEND FOR A FREE SPECIMEN COPY

LOOK FOR THIS TRADE MARK
ON ALL YOU BUY

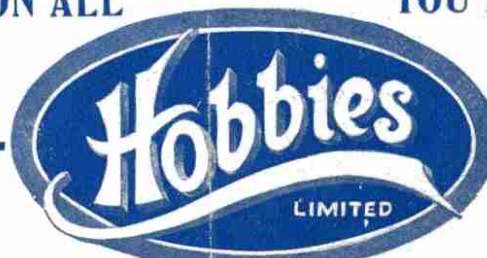

HOBBIES LTD. (DEPT. 36) - - DEREHAM, NORFOLK

65, New Oxford Street, London, W.C.; 147, Bishopsgate, London, E.C.; 79, Walworth Road, London, S.E.; 326, Argyle Street, Glasgow; 10a, Piccadilly, Manchester; 9a, High Street, Birmingham; 214, West Street, Sheffield; 15, County Arcade, Leeds; 11, Bridge Street, Southampton; 68, London Road, Brighton; and Agents everywhere.



FREE
WITH THIS NEW
1925 CATALOGUE

There is a 1/6 design for a Handsome Bureau. There are 216 pages covering 22 different pastimes; 640 Designs and 1,000 Illustrations. Price 9d., or post free 1/-

GET YOUR
COPY NOW

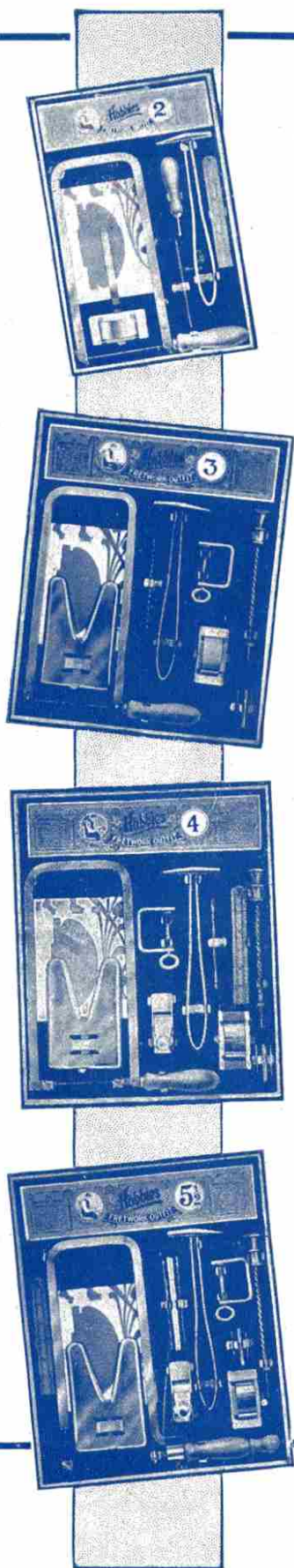

EDITORIAL OFFICE

Binns Road,
LIVERPOOL

Vol. X, No. 1.

MECCANO MAGAZINE



PUBLISHED
IN THE INTERESTS
OF BOYS

January 1925



EDITORIAL

ALTHOUGH for several months past my mail bag has been filled with letters of congratulation from readers, the number of letters received during the past fortnight has easily exceeded that of the previous months combined. To a great extent this is accounted for, of course, by our special Christmas number, which seems to have pleased everybody! I am glad to know that my readers continue to find pleasure in the "M.M." and that they have time to write and tell me so. I can assure them that our future numbers will be even better and more interesting than those of the past. I have several surprises in store and many splendid features are being arranged. As far as possible I am endeavouring to include articles on Wireless, Railways, and Electricity whenever opportunity allows, in addition to our regular and special features. The introduction of pages devoted to Aeroplanes and Airships and to Nature Study is also under consideration and—as mentioned last month—I should welcome my readers' views on these matters and also further suggestions from them for other articles of general interest.

Of our regular features, "The Lives of Famous Engineers" seems to be the most popular—and rightly so, for the thrilling story these articles tell is sufficient to inspire any boy to great deeds. To read of the trials and the triumphs of great men is more than interesting—it is our duty to learn as much as possible about those to whom we owe so much. Moreover, the information contained in this series of articles is very rarely—if ever—found in any other magazines and very seldom in books. The articles are, in fact, the result of considerable research, and a great deal of time and trouble is being given to compiling them. Next month we shall commence the story of two remarkable British engineers, Sir Marc Brunel and his son Isambard Kingdom Brunel. This will be followed by many other articles, dealing with every engineer of note in all branches of Engineering. Next month, too, we shall commence a serial article on Copper,

a further instalment of our regular feature dealing with the Story of Metals. Iron and Steel have already been dealt with under this head, and Copper will be followed by Gold, Silver, Lead, Aluminium, etc. The article on "The New Flying Scotsman" has unfortunately been "crowded out" of this issue, but will be included next month, and also an article on "Handling Goods at the Docks."

It is very pleasing for me to receive hundreds of Christmas and New Year cards every year, and I must acknowledge these messages of goodwill again this year. These cards come from boys at home and abroad

Good
Wishes

—from every part of the world: Canada, Malta, India, South Africa, South America, New Zealand and dozens of other places perhaps not quite so well known. So numerous are the good wishes that I receive that it is impossible for me to acknowledge them individually, and I hope that the senders will accept this announcement as an acknowledgment. I should like to take this opportunity of wishing all my readers every good wish for the New Year. I sincerely hope that 1925 will be for them a year of joy and fun and that they will make good progress in their studies or in their work, as the case may be.

Last month, in mentioning that the price of the "M.M." in future would be increased to 3d., I promised an increase in the number of literary pages, and this takes effect with the present issue. Now that we have more pages available each month, I hope to increase the scope of the Magazine and to be able to include more of those articles that appeal especially to our readers. Being an Editor is no easy task, and as the number of our readers grows, it becomes increasingly difficult to satisfy all requirements. If I were to include all the articles that are suggested, our Magazine would indeed resemble the chameleon that changes its colour every few moments. At the same time it is my wish to give my readers articles on those subjects in which they are particularly interested. Quite between ourselves I may say that the best way to persuade me to include some particular subject is to get all your friends to send post cards to me requesting that such an article should be printed. There must be over 100,000 readers who see the Magazine every month and the wishes of the majority have to be considered in these matters. Thus when only one or two requests are received asking for an article on any particular subject, they cannot be given very serious consideration because it is

Suggestions
Invited

COMPLETE YOUR "M.M." FILES

Those who wish to make up complete sets of "M.M.'s" will be interested to hear that we have in stock a few copies of recent issues.

All Magazines up to and including December, 1921, are out of print. A few dozen copies remain of each number from January to December, 1922, and copies of each of the 1923 issues are also available, with the exception of September and October. Copies will be sent post free, price 3d. each, but early application should be made, as the number available is very small. The price of our last issue (December) is 5d. post free.

evident they do not represent the wishes of the majority of my readers. So now you will all know just what to do, if the "M.M." does not include an article on your favourite subject!

Every Christmas we welcome to our ranks many thousands of new readers. Most of these boys have never seen the

Meccano Magazine before. They may have had their attention drawn to it by one of their friends, or they

may have seen a notice in the Meccano Outfits that were given to them for Christmas presents. For the benefit of new readers I should like to mention that the "M.M." may be ordered from any Meccano dealer, or from any newsagent or bookstall, price 3d. If any reader is unable to obtain the Magazine from either of these sources and will write to me giving full particulars, I will take the matter up on his behalf, as there should be no difficulty whatever in the matter. Those who live too far away from Meccano dealers and newsagents (as do many thousands of our readers, even in this country) may obtain the "M.M." direct from this office, 6 issues for 2/- or 12 issues for 4/- (post free). The next number will be ready on the 1st February. As we print only sufficient copies to fill orders received, every reader should at once place a regular order with his Meccano dealer or newsagent, or direct with this office, to avoid disappointment.

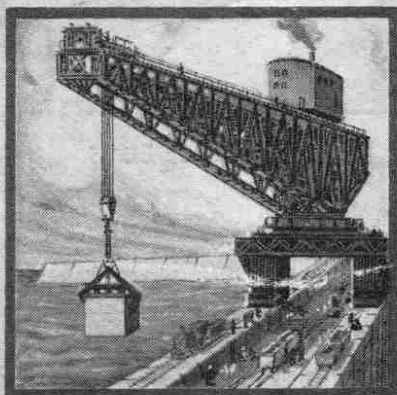

Giant Block-Setting Cranes

Their Work in Constructing
Harbours and Breakwaters

HARBOURS are of great importance to all countries that have any shipping, not only to shelter their ships from the fury of the waves and to enable them to land their cargoes in quiet waters, but also to protect shipping from hostile attack in the case of war.

It is a curious fact that almost every country with a sea coast seems to have at least one natural harbour, and in many cases these are sufficiently large to accommodate large fleets of ships. One of the largest of these natural harbours is the Bay of Rio de Janeiro, which runs in a northerly direction for 15 miles with a width varying from two to seven miles.

Surrounded by high mountains, with an entrance less than a mile in width, it is protected on each side by bold headlands. In Great Britain, Milford Haven in Wales, stretching inland for some 10 miles, is unequalled as a sheltered harbour.

Other natural harbours are formed by the mouths of rivers, such as the Thames, Mersey, Humber, Forth, and the Seine, but their efficiency is somewhat diminished by the "bar" that forms where the out-flowing current of the river is checked by the sea.

Although such natural harbours as these continue to be useful, the requirements of modern times have made it necessary to augment their number, either by improving some natural feature—such as a bay or an inlet—or by constructing more elaborate works and enclosing large areas of the sea by harbour walls or breakwaters.

Our Fleet in Queen Elizabeth's Time

Britain has not always held the proud title of "Mistress of the Seas"—indeed, our supremacy in this direction is of comparatively recent growth. For instance, we were almost entirely without a fleet at the time when Spain, Holland, and France were great sea-powers. When the Spanish Armada rode the seas, the Royal Navy consisted of only twenty-three ships, eight of which were under 120 tons! At this time, however, the Republic of Venice possessed a fleet of over 3,000 vessels carrying more than 36,000 sailors.

Turning to the mercantile marine, we find that in 1540 there were only four vessels of 120 tons burden registered in

the Thames. In Queen Elizabeth's time the shipping of Liverpool amounted to only 223 tons, the largest vessel being of 40 tons burden. How different are things to-day, when the shipping of the Thames and the Mersey runs into almost unbelievable figures, and London and Liverpool between them handle the greater part of the country's trade.

One of the most interesting of all the branches of Engineering is that concerned with the construction of harbours, breakwaters and other structures connected with the sea. This branch of the profession offers splendid opportunities to those who are prepared to work hard and who gain that special knowledge that experience alone can give. It has been said that in its struggle with the sea, modern engineering is seen at its best.

Without entering into further details, we see that even a few hundred years ago neither the Royal Navy nor the mercantile marine was of sufficient importance to require more harbour accommodation than that provided by natural inlets and sheltered bays. On the south coast these were found at such places as Portsmouth, Plymouth, Weymouth, Falmouth and Dartmouth.

The Progress of Harbour Construction

With the growth of our Navy and the increase in our national shipping, greater harbour accommodation became a necessity, and engineers were called upon to design and construct sea-works of one kind or another.

At first these took the form of rough breakwaters, which served to break the full force of the waves, and so protected some natural inlet, converting it into a comparatively safe harbour. The first breakwaters were constructed by floating large stones by means of casks to the places required. The stones were sunk between strong oak piles that had previously been driven into the sea floor at



Fig. 1. Method of Constructing Early Breakwater*

* Figs. 1 and 2 are reproduced from "Engineering for Boys" by permission of Messrs. T. C. & E. C. Jack Ltd.

the place where the breakwater was required (Fig. 1). The ancient pier at Lyme Regis was so successfully constructed in this way that Queen Mary ordered the workmen to be sent to Dover to build a similar breakwater there.

As was only to be expected, these early breakwaters did not long withstand the fury of the waves, but sooner or later were broken up and washed away.

As engineers advanced in their knowledge of this particular class of work, these early types of breakwater gave place to stone piers. More recently these have been superseded by massive monoliths of concrete, such as the mole of Zeebrugge, and the harbour works at Wick, in the north of Scotland.

The largest artificial harbour to-day is that at Portland. It covers an area of over 2,000 acres at a depth of one fathom and 1,500 acres at a depth of five fathoms at low tide. The works were commenced in 1849 and it is interesting to know that they were carried out by convict-labour from Portland prison. The harbour was completed in 1872, but two large additional breakwaters have since been added so as to make the harbour of service in protecting warships from torpedo attack.

Fig. 2 shows a diagram of the scheme of construction of the breakwater at Portland Harbour. As will be seen it consists of a rubble mound, 285 ft. in diameter, just below low water level. Between low water level and high water level is a sloping buttress wall with a high sea wall of solid masonry rising above this.

Protecting our Coasts

Equally important in the branch of engineering under consideration is the designing and building of sea-walls. Sea-walls are very necessary, apart altogether from the fact that they often make delightful promenades from which we may enjoy the sea-air or cast our fishing lines when on our holidays! Unless strong sea-walls are constructed, the constant hammering of the waves soon undermines the cliffs, so that the sea encroaches upon the land and the coast line becomes completely altered.

Some people may be inclined to wonder at the statement that the sea can exert any destructive power upon our coasts, but we have only to notice how the waves lift

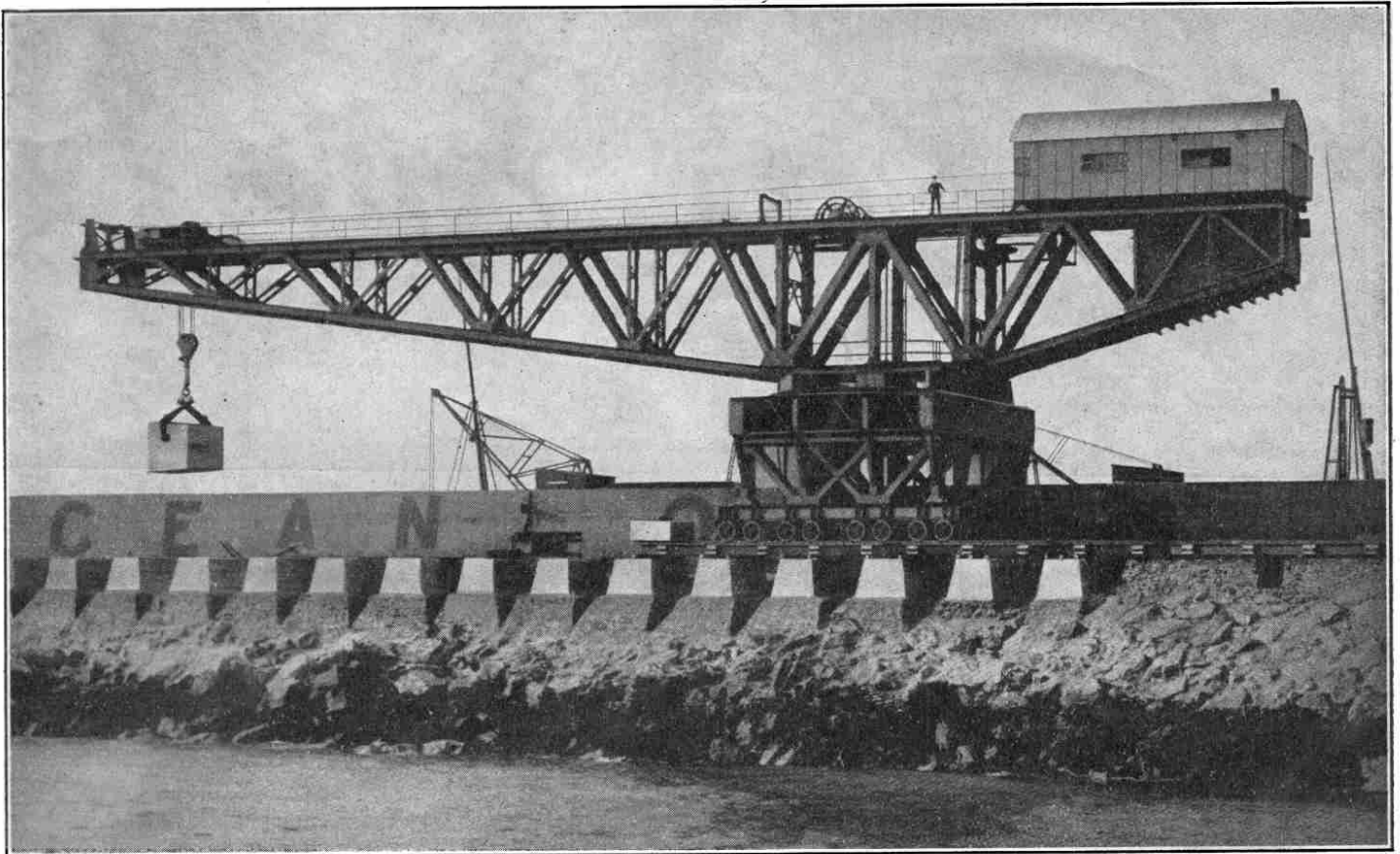

Photo courtesy]

A Giant Crane Setting Massive Concrete Blocks

[Messrs. Stothert & Pitt Ltd.]

pebbles, or even large stones, and roll them along the shore. When we take a "header" through a breaker we sometimes feel these pebbles dashing against us with such force that they give us quite painful blows!

Not only are the waves able to lift pebbles in this way, but they can also lift huge rocks to a considerable height. A heavy sea easily moves rocks and boulders weighing many tons and even tosses them about like so many corks! Having raised them to heights of 40 ft. or more, it dashes them against the cliffs with the action of a giant battering-ram.

The Power of the Waves

Many well-known cases could be mentioned to illustrate the immense power of the sea. For instance, Sir William Mathews, the celebrated engineer, tells us that in 1898 a section of the Peterhead breakwater weighing 3,300 tons was moved bodily by the action of the waves.

In 1871 a harbour wall was built at Wick in Scotland. Composed of concrete blocks—each of which weighed 100 tons—it was capped by two tiers of 80-ton blocks. On top of all was a solid mass of cement weighing 800 tons. One might think that such a heavy structure would surely successfully withstand the action of the waves for many years, and so thought the engineers who built it. We may imagine their surprise, however, when it was found that the sea had not only moved the whole mass, but had actually turned it round and deposited it inside the harbour! As if to show that it could do even more than this when it wished, the sea scattered the 80-ton blocks in all directions. In due course the damage was repaired and

the blocks were replaced. Determined to get the upper-hand, the engineers this time placed on top of the concrete blocks a superstructure weighing more than three times the weight of the original. Before this 2,600 ton superstructure had been in position two years a storm moved it and broke it in half!

A House Falls into the Sea

The sea has indeed, a terrible power and when this is exerted against the cliffs of an unprotected coast, the damage is very great and the sea rapidly encroaches on the land.

A few years ago some friends of mine had a house at Robin Hood's Bay, in Yorkshire, where they spent their summer holidays for many years. The house was delightfully situated, 50 or 60 ft. above the sea, on the top of the cliff overlooking the bay, with a roadway running between the garden and the edge of the cliff. Last summer when I visited Robin Hood's Bay again, I found that the sea had so encroached that not only had it claimed the roadway and the whole of the garden, but half the house also had been undermined by the sea. The old house was standing without the outer walls, which had fallen into the sea. All the rooms were open to the sea, and the whole building

resembled a sectional view of a modern dwelling!

All along this part of the Yorkshire coast—from Whitby to Spurn Point—the sea is making great inroads, claiming many acres of land every year. At some parts of the coast substantial and heavily-built sea-walls have been erected to keep the sea back, but it is only a question of time before they too are attacked by the relentless action of the waves, so that constant repairs, or even rebuilding, becomes necessary.

Special Cranes Employed

In carrying out the construction of all sea works, cranes are particularly useful to the engineer. The type of crane used varies according to the nature of the work in hand, which in turn depends largely on local conditions and the special requirements arising therefrom. It is no exaggeration to say that without mechanical aid of this kind it would have been quite impossible to construct most of the great sea works of to-day.

Among the most useful cranes are those of the Giant Block-setting type, such as is illustrated on this page and on our coloured cover. For the loan of illustrations for both these, we are indebted to Messrs. Stothert & Pitt Ltd., of Bath, who specialize in this class of crane.

To enable us to understand the particular work in which these block-setting cranes are employed, we must learn something of the developments of harbour construction. In the first place it should be mentioned that no two breakwaters or harbours are exactly alike, and almost every harbour requires particular treatment. In one case a mound

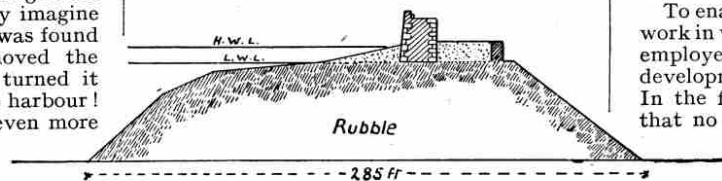
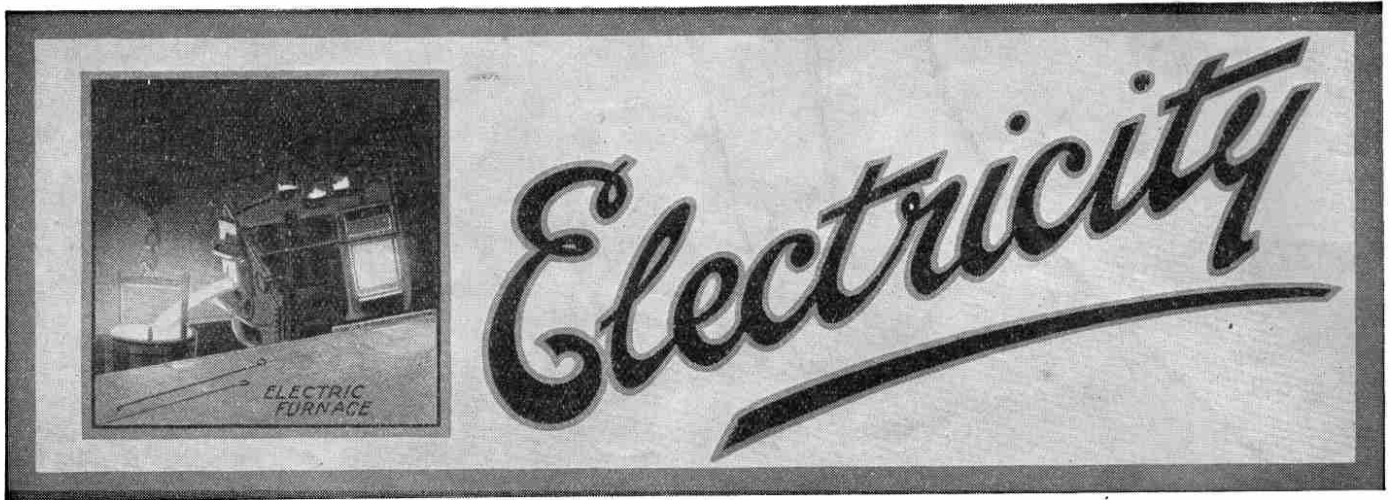

Fig. 2. Diagram of Section of Portland Breakwater

(Continued on page 40)



XI. ELECTRIC SIGNS

MOST people who have visited London will remember Piccadilly Circus with its string of traffic, its ceaseless stream of people, and at night its marvellous electric signs. When daylight has gone the scene is made brilliant by the ever-changing designs and colours of these elaborate advertisements, which in Piccadilly Circus are so numerous and so interesting that the locality has been humorously called: "The Scotsman's Cinema."

Stationary Signs

There are two distinct classes of electric signs, those that are merely switched on and off at stated intervals, and the so-called moving signs.

Stationary signs are by far the most common, and are to be found not only in London but in the principal shopping streets of most large towns. They are the simplest signs to work and are also the most economical in regard to both original outlay and cost of upkeep. In signs of small or medium size it is usual to form the design by means of sheets of metal out of which are cut the shapes of the letters or figures to be illuminated. Behind the cut metal is a piece of glass, frosted or made white by some other means, and behind the glass is a row of electric lamps. When these lamps are switched on they light up the openings in the sheet of metal and the design stands out as a blaze of light.

Many stationary signs are merely lit at dusk and extinguished at some late hour of the night. Even these may be made much more striking by the use of various switching devices, the simplest of which is a timing arrangement whereby the lamps are extinguished for a short period at certain regulated intervals. This timing device is driven by an electric motor through worm reduction gearing, and works on the principle shown in Fig. 1.

The metal brush B presses against the rim of the commutator wheel C which is turned very slowly by an electric motor (not shown). The rim of this wheel consists half of copper or brass and half of rubber or some other suitable insulating material. In the diagram the copper is the shaded portion, and this

is electrically connected to the axle on which the wheel revolves and on which there is also another wheel, usually smaller, consisting entirely of copper. On this wheel the brush B1 presses, and it will be seen that when brush B is on the copper portion of the large wheel C there is electrical connection between the two brushes. When brush B is on the rubber portion of this wheel, however, there is no electrical connection and accordingly the current is switched off.

The wiring is simple. From one of

the mains arriving from the power station a wire is taken to brush B1. Another wire leads from brush B to one of the terminals of the lamps, and from the second terminal of the lamps a wire goes to a control switch and from there to the other main. The switch is turned off when the sign is not required to work, and it is usually arranged that it both stops the motor and turns out the lights.

Signs that Change Colour

Another type of sign is similar to that described above, but is lighted alternately by red and white lamps. This is accomplished as shown in Fig. 2. From one of the mains a wire is taken to the brush B1, which presses on the all-copper commutator C1. This commutator is electrically connected to the axle on which it revolves, and which also carries the commutators C2 and C3, shown separately in the diagram for the sake of clearness.

The axle with its three commutators is driven slowly by the electric motor as before. The rims of the commutators C2 and C3 each consist of half copper and half rubber, and are so adjusted that when the copper portion of C2 is under brush B2 the rubber portion of C3 is under brush B3. The copper portions of C2 and C3 are electrically connected to the all-copper commutator C1 through the axle.

A wire is taken from brush B2 to the white lamps in the sign, from which it passes to the control switch and to the other main. Another wire goes from brush B3 to the red lamps in the sign, from which it passes to the same switch and uses the same wire from the switch to the main. Thus it will be seen that, as the axle carrying the commutators revolves, each set of lamps will be alternately switched on and off, and by means of the relative positions of the copper portions of the commutators C2 and C3 the switching is timed so that the red lamps are on when the white ones are off, and vice versa. The sign thus shows the design or words alternately in red and white. Of course, any other two colours of lamps may be used, and if additional commutators are used, more colours may be added.



Photo courtesy]

[Messrs. Franco-British Electrical Co. Ltd.

The L.M.S. Illuminated Sign now showing in
Leicester Square, London

By regulating the size of the copper portion of the commutators the lamps of one colour may be made to light up shortly before the others go out, or the second colour may light up at the exact moment when the first goes out, or there may be an interval of darkness between the two colours.

These metal signs are only suitable for comparatively small signs. Large stationary signs are composed entirely of rows of lamps arranged in the shapes of the letters required, no metal sheet being placed in front. When this type of sign is required to change colour, lamps of the two colours are placed alternately in the rows.

Moving Signs

So-called moving signs require considerably more complicated switching arrangements than are necessary for the working of stationary signs. The principle remains the same in each case, but it is extended to every lamp that is required to "move."

Fig. 3 shows the wiring of a portion of a moving sign. One terminal of each lamp is connected direct to one of the mains through the thick wires A.B.C., D.B.C. The other terminals of the lamps each have independent wires to separate brushes on a large commutator, the brass segments of which are all connected to the axle. On the axle is also a solid brass commutator with a brush connected to the wire E, which passes to the other main through the control switch.

Those lamps will light up whose brushes are in contact with the brass segments of the commutator at any particular moment. Consequently, as the commutator revolves, different lamps will glow according to the arrangement of the segments, and thus any desired series of designs or words may be obtained. Changes in the series of designs are obtained by having several interchangeable commutators. When only a few sets of words or designs are required certain lamps may be linked together so as to use only one brush for the whole.

Largest Electric Sign in the World

Although many electric signs appear to move, no movement actually takes place, the illusion being produced in much the same way as the motion in cinema films. For example, in order to make a spot of light travel round a circle, a circle of lamps is used, and when these lamps are lighted one after the other very rapidly, by means of switch mechanism, a spot of light appears to be travelling round the circle, whereas in reality what we are

seeing is a new and stationary spot for every position.

It is on this principle that the most elaborate moving signs are based, including even the largest electric sign in the world,

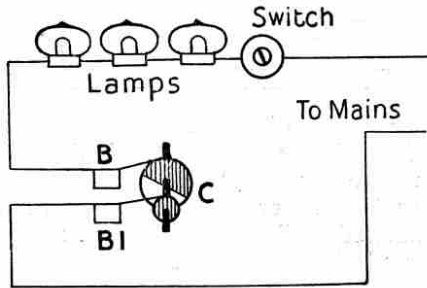

Fig. 1

owned by Wrigley's of "Spearmint" fame. This monster sign is situated in Broadway, New York, is 200 ft. in length and 15 ft. in height, has 17,266 lamps and costs £1,800 per month to run! Two

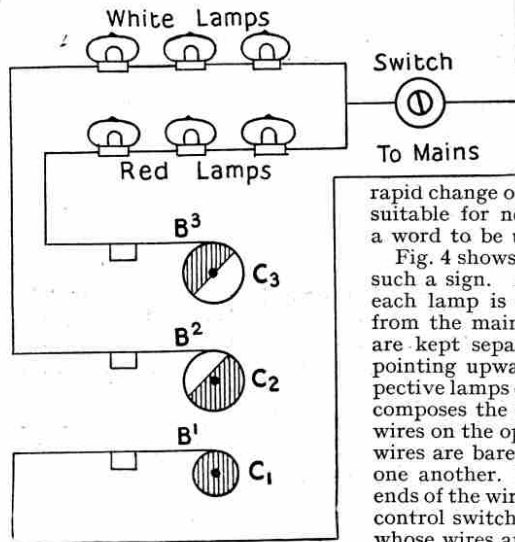

Fig. 2

peacocks with tails 60 ft. in length occupy the centre of the sign at the top. Below is the word "Wrigley's," and below that again is another word that is changed at frequent intervals. On both sides of these two words are three "spearmen" 15 ft. in height, who perform nine different actions. At each end of the sign play fountains nearly 40 ft. in height, consisting of lamps of different colours. Below the whole is an arabesque or ornamental design about 10 ft. in depth.

As in the case of most signs of very large size, the Wrigley sign is divided into several sections on the switchboard. One of these sections contains all the lamps that remain lighted during the whole time the sign is working; a second section contains the switch-gear for the fountains; a third controls the move-

ments of the "spearmen," while a fourth has charge of the two words in the centre, which are moved only at certain intervals.

Our illustration on the previous page shows the famous London, Midland and Scottish Railway sign in Leicester Square, London. This sign shows the train apparently in movement. To the spectator smoke appears from the funnel and streams behind; the wheels revolve; the piston and coupling rods move up and down; shadows stream along the track so as to produce the illusion of a moving train. Actually the train remains stationary, of course, and the effect is produced by making the track apparently move in the reverse direction, just as the galloping horses on the revolving stage at Drury Lane remained still while the platform revolved.

As we have already explained, no actual movement takes place in the sign at all. The effect is the result of timing contact mathematically so that shadows are produced that appear to move from one lamp to another. In other words, one series of lamps is extinguished simultaneously with the lighting-up of another series, and the eye assumes that movement has taken place from one position to another.

For News Bulletins

A type of moving sign has been invented recently that allows of the rapid change of a series of words, and this type is particularly suitable for news bulletins and similar items that require a word to be used once only.

Fig. 4 shows the wiring of eight lamps of one of the rows in such a sign. As in the previous examples, one terminal of each lamp is connected permanently to one of the wires from the main. The wires from the other lamp terminals are kept separate and are arranged with their bare ends pointing upwards in a row in the same order as their respective lamps on the sign. Thus, if a solid rectangle of lamps composes the sign there is also a solid rectangle of ends of wires on the operating table. Although the ends of all these wires are bare, the individual wires are kept insulated from one another. Metal letters in relief are passed across the ends of the wires, and as these letters are connected through a control switch to the mains, those lamps are lit on the sign whose wires are touched by the faces of the letters, and the lamps illuminated have the same shapes as the letters on the table.

The letters are attached to each other by hooks, and a chain of these letters, forming a sentence, is pulled across the ends of the wires, the result on the sign being that the words of light move across it from right to left, the beginning of the sentence moving off the edge of the sign on the left while more is being added on the right. When the new letters have passed across the operating table they are unhooked and then recombined to make fresh words and sentences. In this way people in the street below are able to read paragraphs of news or advertising matter.

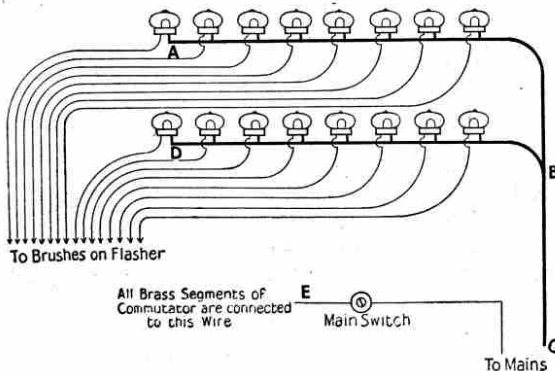

Fig. 3

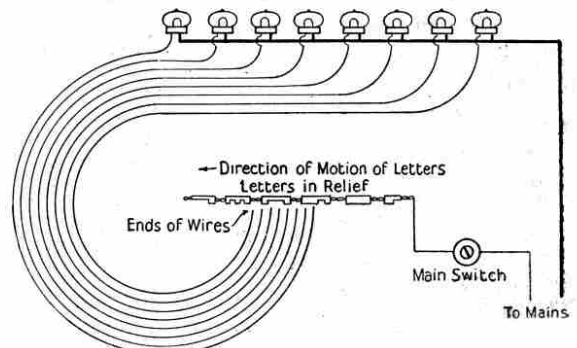

Fig. 4

The Triumphs of Great Men Over Loneliness and Poverty

OUR hearts always go out to the boy or man who is poor and lonely. Most of us have felt lonely at some time or other and some of us have known what poverty means, yet it would be wrong to consider loneliness and poverty as altogether unmixed evils.



Alexander Dumas

Romance and history teem with instances of boys and men who have triumphed over loneliness and poverty to rise to heights of power and responsibility far above their fellow men.

Loneliness and Poverty in Fiction

Who has not read the moving story of John Halifax, who commenced life as a lonely, friendless boy, sleeping in country out-houses and in the

fields? John Halifax's first job was that of a labourer in a tan-yard, and he rose to eminence by dint of sheer determination, hard work and force of character.

Another example is found in the story of the Abbé Faria in that fascinating book, "*The Count of Monte Cristo*," by the wonderful writer Alexander Dumas. The wonderful old Abbé Faria spent the last years of his life in a lonely prison cell. Here he learned languages, wrote books, and arrived at the correct solution of a profound and intricate problem which enabled him to enrich a fellow prisoner and launch him upon his amazing career as the Count of Monte Cristo.

Hundreds of similar romances have been woven round the fascinating themes of poverty and loneliness, and pages of examples might be given. Wonderful as these romances of fiction are, they pale into insignificance when compared with the yet more wonderful stories of actual life.

Triumphs of Real Life

The ex-Prime Minister of England, Rt. Hon. Ramsay



J. Ramsay Macdonald

Macdonald, began life in a two-roomed cottage. He was born in Lossiemouth, a tiny village in the Scottish Highlands, in circumstances of poverty such as I hope fall to the lot of none of my readers. Although young Macdonald had little learning, and no more opportunities of advancement than usually fall to the lot of the average village boy, he had within him what Robert Burns—

one of his great countrymen—called that "spark o' nature's fire" that triumphs over every adversity and knows no defeat. At the age of 19 Macdonald walked the streets of London without money or friends. He addressed envelopes to earn his living, and his first real job brought him 12/6 per week. His life story has a long way to run yet, but we can have little doubt that the influence of this once poor and lonely boy has had a marked effect on the history of our country.

A Great American

President Abraham Lincoln, an outstanding and commanding figure in the world's history—whose life and

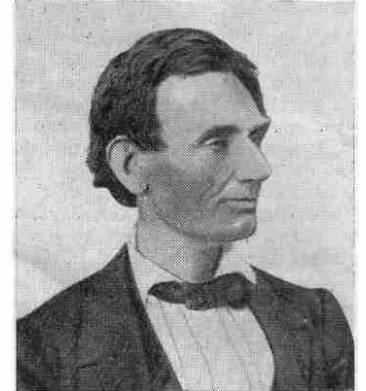

[Courtesy] [Messrs. Constable & Co. Ltd.]

Abraham Lincoln

sayings I hope you will all read some day—began life in circumstances that even the loneliest and poorest boy would scarcely envy. Lincoln was born in a log cabin on a bleak farm in Kentucky, three miles from the nearest village. Life in those days was indeed very primitive, with an entire absence of most of the home and social conveniences that every boy now takes as a matter of course. There was no education, and little to soften the general conditions of abject poverty. Of his early life Lincoln said later: "It is a great folly to try to make anything out of me or my early life. It can all be condensed into a single sentence, and that sentence you will find in Gray's '*Elegy*'—'The short and simple annals of the poor.' That's my life, and it is all you or anyone else can make out of it." Yet, from its modest commencement, Lincoln's life was a steady progression towards the attainment of his ideals for the unity and freedom of the great American nation, and to this purpose his whole life was dedicated.

An Immortal Writer

The name of Charles Dickens is beloved wherever the English language is spoken or read. We think of him as a writer of charming and moving stories, as a creator of lovable characters—Micawber, Captain Cuttle, Pickwick, Sam Weller and a host of others. He it was who made our British Christmas a time of good will, a time for giving presents to boys and girls, a time of kindly



Charles Dickens



Sir J. M. Barrie

thought and jollity. I shouldn't wonder if that present of a Meccano Outfit or Hornby Train, which came from your mother last Christmas, is not directly traceable to the influence of Dickens. Read his "*Christmas Carol*" or "*Pickwick Papers*" if you want to know what a real Christmas should be like!

Dickens had a hard time as a boy. His father died while he was very young, and he was sent to work in a factory at an occupation that was dreadfully unpleasant and distasteful. Out of his loneliness and poverty came that great love for the poor and needy, and that great determination to rectify their wrongs, which later found such wonderful expression and bore such ripe fruit in his immortal writings.

The Creator of "Peter Pan"

Another great British writer, Sir J. M. Barrie, whose name cannot be mentioned and whose works cannot be read without conjuring up thoughts of warmth and friendliness, has said: "The greatest glory that has ever come to me was to be swallowed up in London, not knowing a soul, with no means of subsistence, and the fun of working till the stars went out." The spirit that was chastened and moulded in this loneliness finally emerged and gave us "Peter Pan" and a wealth of other joyous and happy books and plays, which all my readers will come to love. A short time ago, in an address to boys on "Courage" (which I think you would enjoy reading), Barrie concluded by saying: "Courage, my children, and greet the unseen with a cheer." That is ever his message in all his writings. Welcome all your troubles as new adventures and greet them with a courageous shout.

A Pit Boy Who Rose to Fame

In every walk of life there is no dearth of examples of triumph won, despite loneliness and poverty. We all know Sir Thomas Lipton. We may not have met him, of course, but we have seen his friendly face smiling at us from the pages of our illustrated papers, and we have smiled back at him, and we have admired his great efforts to bring the Yachting Cup to England with his famous "*Shamrocks*." Lipton started life as an errand boy in a grocer's shop in Glasgow. He was friendless and poor, but by application and enterprise he established a great and successful business. Lipton's great friend

of later days, Sir Harry Lauder, started as a pit boy in a coal mine, but his cheeriness, which still comes to us in generous measure over the foot-lights, pulled him safely through all his tribulations and finally brought him to fame and fortune. If you would see the brave spirit that shines behind the cheery face of this artist, you must read his book "*A Minstrel in France*."

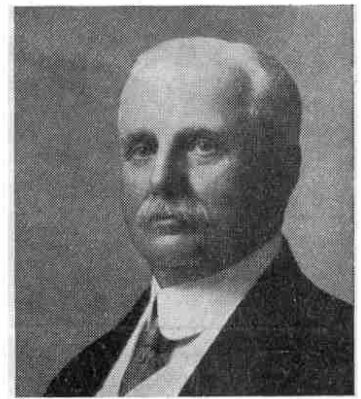

The late Frank W. Woolworth

Farmer to Millionaire

More than fifty years ago a boy was born in Jefferson County, in the State of New York. He was the son of a farmer, and seemed likely to follow in his father's footsteps. Later he developed other views, however, and as a young man took a situation without a salary in a dry goods store. In three months he was paid 15/- a week, and in two years 25/- a week. He then conceived the idea of opening a shop where everything was to be sold at a fixed price, and he devoted the whole of his business life to the development of this idea. A few years ago he erected a building with 57 stories, the tallest building in the world. It cost £3,000,000 and was paid for out of the profits of his one idea. You have all probably guessed the name of this great man—Woolworth—whose name is almost as well known in this country as in America. Speaking of his early life he has said: "I had to open the store at 7.0 a.m. and remain each night until 10 o'clock. There was no work too mean or dirty for me to do. I was discouraged. I thought it was impossible for me ever to learn the business. Well, I went on and the world knows the result."

The Value of Courage

These and many other successful men began their lives in loneliness and poverty, and the story of their careers should be an inspiration to any boy who feels inclined to bewail his own loneliness and lack of opportunities. Out of loneliness and poverty come determination, independence, courage and high ambition, and the greatest of these is courage. This surely is the quality that triumphs in times of trial and disappointment, and turns our stumbling-blocks into stepping-stones. Courage causes half our troubles to vanish before they have time to take definite shape, and reduces the other half to impotence.

A Model Dockyard

There are few pastimes more fascinating than model-boat sailing, and given a well-designed boat and a suitable sheet of water the scope for fun and excitement is almost unlimited. It is very necessary, however, that the boat should be obtained from a firm that really understands the building of these miniature vessels. A visit to the premises of the Kensington Model Dockyard (185, Kensington High Street, London, W.8) reveals a tempting display of boats of all kinds. The resources of the Dockyard are not confined to boats, however, but extend to model aeroplanes, engines, and fittings of every description, photographic apparatus and a wonderful range of requisites for indoor and outdoor games.

For Electrical Experimenters

The wireless boom has had the effect of drawing general attention to the fascinations of electrical experiments, and the demand for electrical apparatus and parts is increasing. The Grafton Electric Co. (54, Grafton Street, Tottenham Court Road, London, W.1.) have laid themselves out to meet this demand, and they are able to fill the most exacting requirements. In addition to a wide range of complete wireless sets and component parts, their catalogue includes a great variety of reliable primary cells, both dry and wet, and accumulators of all sizes and capacities. A speciality is made of miniature lighting sets, and also brackets, shades, switches and everything for those who wish to assemble their own sets.

Model Steam Engines

Messrs. Stuart Turner Ltd. (Henley-on-Thames), well known to model-builders for the splendid quality of their products, send us a copy of the new edition of their catalogue (price 6d.) This includes engines of all types—steam, gas, and petrol—which are supplied both in the form of castings to be built up or as finished engines ready for work. A particularly interesting item is the "S.T." steam plant specially designed for driving Meccano models, boats, or any small machinery. Another noteworthy set is the "B.B." generating plant consisting of an engine and dynamo mounted on a suitable base, the electrical output of the plant being 20 watts. Almost every possible requirement of the model engineer is provided for.

MECCANO

ACCESSORY PARTS

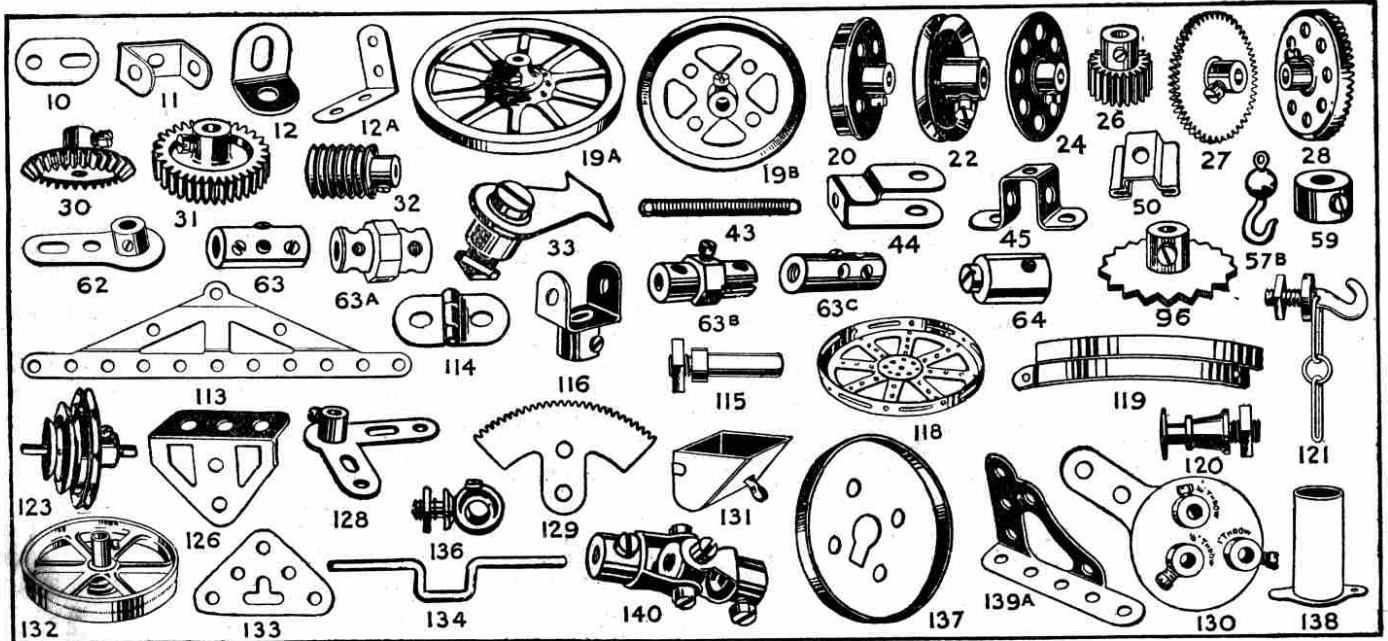

We illustrate above a selection of accessory parts that every Meccano boy will find useful for building the larger and more interesting models. Sometimes a model may be described in these pages that is beyond the capabilities of one of the smaller Outfits, but by purchasing a few extra parts, it becomes possible to build the model.

Then again, where it is not desired to purchase an Accessory Outfit in the first instance, an Outfit may be gradually converted into a higher Outfit by purchasing the necessary parts, from time to time.

Many of these parts have only recently been introduced, and although we know that they have a universal use (were

it otherwise they would not have been added to the system) we may not yet know *all* their applications. There are endless possibilities in the application of Meccano parts, and brainy boys endeavour to find new applications for them. These parts make possible the invention of entirely new models, and this provides more fun than merely copying the models in the Meccano Manuals.

If you have any difficulties in connection with using these parts, or any suggestions for new parts not already in the system, write to Meccano Ltd., Binns Road, Liverpool, and mark your envelope "Bright Ideas."

No.		s.	d.
10.	Flat Brackets	½ doz.	0 2
11.	Double Brackets	each	0 1
12.	Angle Brackets, ½" x ½"	doz.	0 6
12A.	" " 1" x 1"	each	0 1
12B.	" " 1" x ½"	"	0 1
19A.	Wheels, 3" diam. with set screws	"	0 8
20.	Flanged Wheels	"	0 6
Pulley Wheels.			
19B.	3" dia. with centre boss and set screw	each	0 8
19C.	6" " " " " " "	"	2 6
20A.	2" " " " " " "	"	0 6
21.	1½" " " " " " "	"	0 6
23A.	¾" " " " " " "	"	0 4
22A.	1" " without	"	0 2
23.	¾" " " " " " "	"	0 2
24.	Bush Wheels	"	0 6
25.	Pinion Wheels, ½" diam.	"	0 6
26.	" " ¾" " "	"	0 4
27.	Gear Wheels, 50 teeth	"	0 9
27A.	" " 57 " "	"	0 9
28.	Contrate Wheels, 1½" diam.	"	0 9
29.	" " 2" " "	"	0 6
30.	Bevel Gears	"	0 10
31.	Gear Wheels, 1", 38 teeth	"	1 0
32.	Worm Wheels	"	0 6
33.	Pawls (complete)	"	0 4
33A.	Pivot Bolts with Nuts	"	0 2
43.	Springs	"	0 2

No.		s.	d.
44.	Cranked Bent Strips	each	0 1
45.	Double Bent Strips...	"	0 1
50.	Eye Pieces	"	0 2
57.	Hooks	"	0 1
57A.	" (scientific)	"	0 1
57B.	" (loaded)	"	0 5
58.	Spring Cord	per length	0 9
59.	Collars with Set Screws	each	0 2
62.	Cranks	"	0 3
62A.	Threaded Cranks	"	0 4
63.	Couplings	"	0 6
63A.	Octagonal Couplings	"	0 8
63B.	Strip Couplings	"	0 8
63C.	Threaded Couplings	"	0 6
64.	Threaded Bosses	"	0 2
65.	Centre Forks	"	0 2
94.	Sprocket Chain	per length	0 6
95.	Sprocket Wheels, 2" diam.	each	0 5
95A.	" " 1½" " "	"	0 4
95B.	" " 3" " "	"	0 6
96.	" " 1" " "	"	0 3
96A.	" " ¾" " "	"	0 3
109.	Face Plates, 2½" diam.	"	0 4
113.	Girder Frames	"	0 2
114.	Hinges	per pair	0 4
115.	Threaded Pins	each	0 2
116.	Fork Pieces	"	0 3
117.	Steel Balls, ¾" diam.	doz.	0 6

No.		s.	d.
118.	Hub Discs (5½" diam.)	each	1 3
119.	Channel Segments (8 to circle, 1½" diam.)	"	0 4
120.	Buffers	"	0 2
120A.	Spring Buffers	per pair	0 8
121.	Train Couplings	each	0 4
122.	Miniature Loaded Sacks	"	0 2
123.	Cone Pulleys	"	1 3
126.	Trunnions	"	0 3
126A.	Flat Trunnions	"	0 2
127.	Simple Bell Cranks	"	0 3
128.	Boss Bell Cranks	"	0 4
129.	Rack Segments, 3" diam.	"	0 6
130.	Triple Throw Eccentrics	"	1 3
131.	Dredger Buckets	"	0 2
132.	Flywheels, 2½" diam.	"	2 3
133.	Corner Brackets	"	0 3
134.	Crank Shafts, 1" stroke	"	0 3
136.	Handrail Supports	"	0 3
137.	Wheel Flanges	"	0 4
138.	Ship's Funnels	"	0 4
139.	Flanged Brackets, right	"	0 2
139A.	" left	"	0 2
140.	Universal Couplings	"	0 9
141.	Wire Lines (for suspending clock weights)	"	0 9
142.	Rubber Rings	"	0 4
143.	Circular Girders, 5½" diam.	"	1 0

You may obtain these parts from your dealer, or direct from MECCANO LTD., BINNS ROAD, LIVERPOOL.

A NEW MECCANO MODEL

Model No. 734. Ship-Coaler

(Continued)

LAST month we learned something of the work done by mechanical coalers in coaling ships at high speed, and we gave the first part of the instructions for building a splendid Meccano model of a High-Speed Ship-Coaler. In this issue we continue these instructions and give also a list of parts required to build the model.

The High-Speed Ship-Coaler is one of the most interesting of Meccano models, for all the movements for coaling a miniature ship are controlled from the gear-box. The model will appeal to every Meccano boy, because when it has been built it affords endless fun, and no little dexterity is required for its operation. There are so many movements that the operator has to use his intelligence and has to be quick with his fingers in order to carry out all of them successfully.

Motor Control Mechanism

Having constructed the main tower and the run-ways for the grab, we proceed to fit the Electric Motor (12, Fig. B), which is started, stopped or reversed by the handle (13). This is connected to a Bell Crank (14) pivotally mounted on a Rod (15) journalled in Trunnions and coupled by a 2½" Strip (16) to the control handle of the Motor.

From a ¾" Sprocket Wheel on the Rod (17) the Motor drives a 1½" Sprocket (18) on the Rod (19, Fig. B), which carries two ½" Pinions (20 and 21, Figs. B and C) on either side of the Rod (19).

These are slideably mounted in the Perforated Plates (42). On the ends of the two Rods (22 and 23) are Double Brackets enclosed by Collars (24), the Brackets being connected to 3½" Strips (25 and 26). These Rods (22 and 23) form operating levers for pushing the Rods (22 and 23) in or out.

The Double Brackets are lock-nutted to the bolts pivotally connecting them to the Strips (25 and 26), so as to enable the Strips to move freely on the bolts without disturbing their connection with the Double Brackets. Similarly, the pivotal

bolts of the Strips (25 and 26) are lock-nutted to the 1" Brackets (27), leaving the pivotal Nuts of the Strips (25 and 26) free on these Bolts.

The Gear-Operating Mechanism

A 57-toothed Gear Wheel (28) on the Rod (22) is adapted to engage or disengage with the Pinion (20) on the Rod (19). This drives the Roller (29) on which are wound the cords (30). These open and close the grab, details of which were shown in the larger illustration last month.

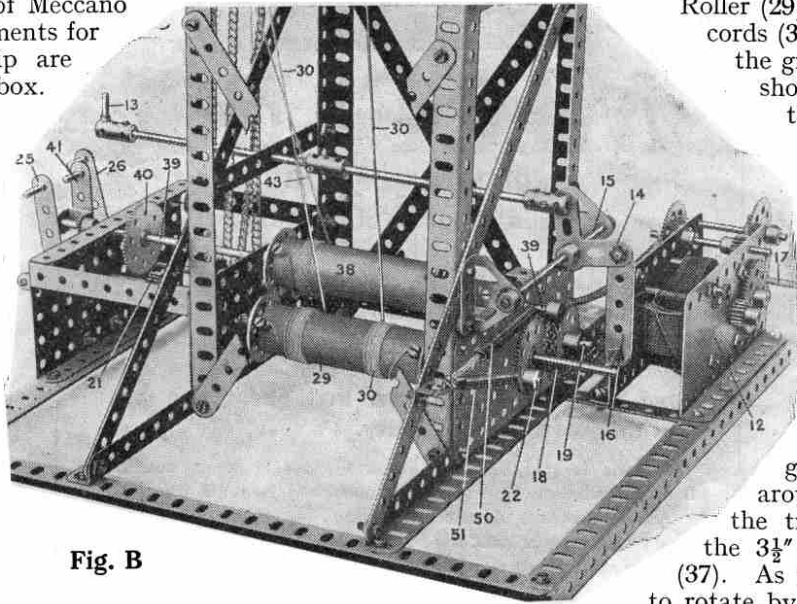

Fig. B

The cords pass from the Roller (29, Fig. D) over the Pulleys (31) and over the outer top Pulleys (32), returning down and passing around ½" Pulleys (33) on to other ½" Pulleys (34) on the trolley. From thence the cords pass down and around 1" Pulleys (35) on the grab, and returning up around ½" Pulleys (36) on the trolley, are made fast in the 3½" x ½" Double Angle Strip (37). As the Roller (29) is caused to rotate by the Motor in one or other

direction, the grab will be raised or lowered.

Another Roller (38, Figs. B and C) is mounted on the 11½" Rod (39). This Rod slides in the Plate (42) directly above the 11½" Rod (19) carrying the Pinion (21, Figs. B and C). A 57-toothed Gear Wheel (40) on the Rod (39) is engaged or disengaged with the Pinion (21) by the operation of the 3½" Strip (41). This Strip acts as a control handle in a similar manner to the Strips (25 and 26) and is lock-nutted to the pivotal bolts as previously described.

Opening and Closing the Grab

When the Gear Wheel (40) is engaged with the Pinion (21), which is on the Rod (19) driven by the Motor, the Roller (38) rotates and the cord (43) on that Roller is wound up. This cord passes over an outer 1" Pulley (44), over a central 1½" Pulley (45) at the extreme top, down and around a ½" Pulley (46) to the trolley over a ½" Pulley (47) thereon. It passes around a 1" Pulley (48) on the grab below, returning up to and over a ½" Pulley (49) on the trolley, where it is made fast to

(Continued on page 11)

Parts required :

28 of No. 1	2 of No. 17	1 of No. 48D
5 " " 1A	2 " " 18A	1 " " 52
14 " " 2	3 " " 18B	2 " " 53
6 " " 2A	8 " " 20	1 " " 53A
24 " " 3	3 " " 21	1 " " 54
10 " " 4	5 " " 22	50 " " 59
18 " " 5	14 " " 22A	3 " " 63
2 " " 6	10 " " 23	2 " " 70
4 " " 6A	4 " " 24	2 " " 72
8 " " 7	3 " " 26	4 " " 76
6 " " 8	4 " " 27A	2 " " 77
6 " " 9	12 " " 35	4 " " 90
1 " " 9A	280 " " 37	48" " 94
4 " " 10	16 " " 37A	1 " " 95A
6 " " 11	30 " " 38	2 " " 96A
18 " " 12	1 " " 40	2 " " 103D
5 " " 12A	2 " " 43	2 " " 106
3 " " 13	3 " " 44	2 " " 108
3 " " 14	2 " " 45	2 " " 111
2 " " 15	1 " " 46	8 " " 115
3 " " 15A	1 " " 48	1 " " 124
6 " " 16	7 " " 48A	2 " " 125
2 " " 16A	11 " " 48B	4 " " 126
2 " " 16B	1 " " 48C	1 " " 128

Meccano Outfits may be obtained from all leading toy stores

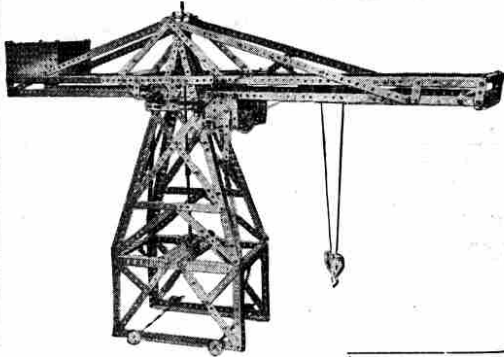

Radial Crane

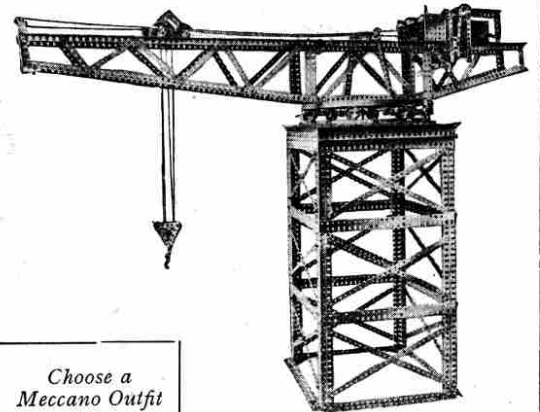

Hammer-Head Crane

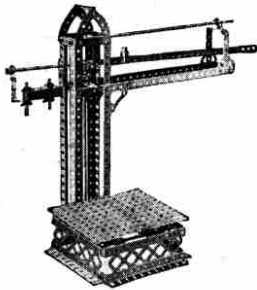

Platform Scales

This No. 2 Outfit costs 15/- and builds 163 Models.



Choose a Meccano Outfit for Your New Year Gift.

MECCANO

ENGINEERING FOR BOYS

You can build hundreds of working models with Meccano: Cranes of all types, Big Wheels, Motor Chassis, Lathes, Clocks, Looms that weave real fabric, and hundreds of others all equally interesting. No study is needed, you can commence building immediately you open your Outfit. The big illustrated Book of Instructions that goes with each Outfit makes everything easy.

Meccano is sold in nine Outfits of varying sizes, numbered 00 to 7, and each Outfit may be converted into the one higher by adding the next Accessory Outfit. Thus if a No. 2 Outfit is bought it may be converted into a No. 3 by purchasing a 2a; a No. 3a would then convert it into a No. 4, and so on up to No. 7.

COMPLETE OUTFITS

No. 00	3/6
No. 0	5/-
No. 1	8/6
No. 2	15/-
No. 3	22/6
No. 4	40/-
No. 5	(in well-made carton)	55/-
No. 5	(in superior oak cabinet with lock and key)	85/-
No. 6	(in well-made carton)	105/-
No. 6	(in superior oak cabinet with lock and key)	140/-
No. 7	(in superior oak cabinet with lock and key)	370/-

ACCESSORY OUTFITS

No. 00a	1/6
No. 0a	4/-
No. 1a	7/6
No. 2a	8/6
No. 3a	18/6
No. 4a	15/-
No. 5a	(in well-made carton)	50/-
No. 5a	(in superior oak cabinet with lock and key)	80/-
No. 6a	(in superior oak cabinet with lock and key)	210/-

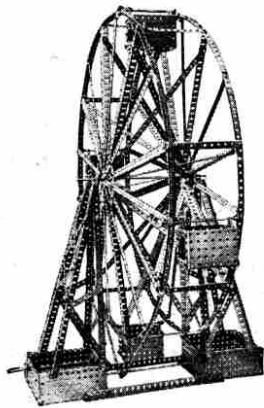

Big Wheel

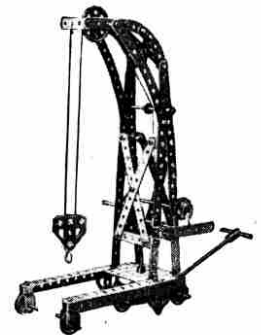

Platform Crane

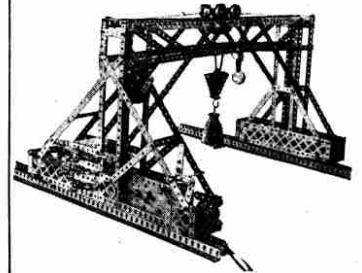

Gantry Crane

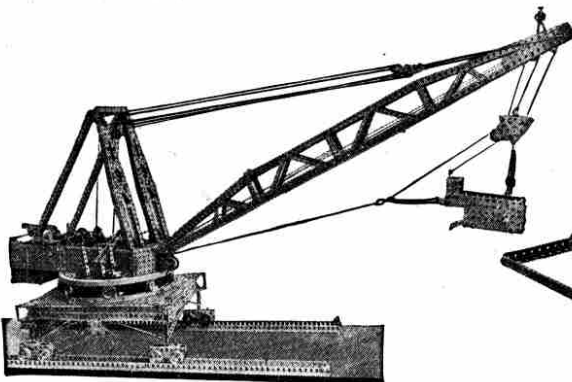

Dragline

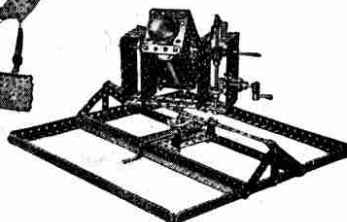

Searchlight

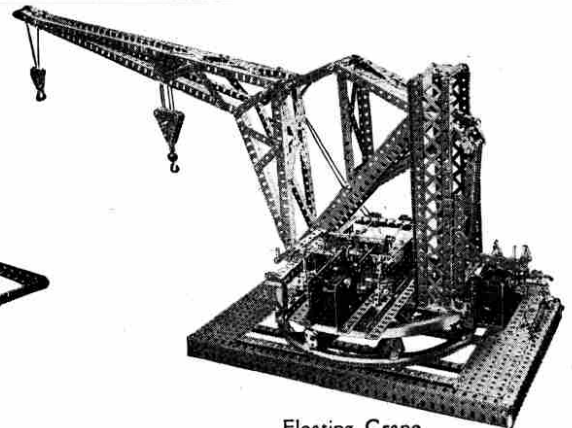

Floating Crane

MECCANO LTD.

BINNS ROAD

LIVERPOOL

A New Meccano Model—(cont. from page 9)

the Double Angle Strips (37). Consequently by manipulating the handle (41) the grab may be opened or closed if it is stationary.

When both the handles (41 and 25) throw the Rods (39 and 22) in gear with the main driving Rod (19), the grab is hoisted or lowered in an open or closed condition.

The Action of the Model

A Spring (50, Fig. B) is engaged over the end of the Rod (39) carrying the Roller (38) and another Spring (51) on the end of the Rod (22). These act as frictional drags or brakes on these Rods, preventing the load in the grab running away when the gears are out of mesh.

The mechanism is designed so that a load may be picked up by the grab at the outer end of the trolley arm. The load is then raised and the grab travels inwards on the rails (3). Meanwhile, the truck simultaneously travels inwards until, when the grab is over the truck, it (the grab) is opened and the load deposited in the truck.

Both the truck and the grab then travel outwards, the movement being completed by the truck depositing its load down the chute.

The Travelling Grab

This inward and outward travelling action of the grab and the truck is effected from the third handle (26, Fig. C). This controls the Rod (23) on which a 57-toothed Gear Wheel (52), when engaged with the Pinion (20), causes the Rod (23) to be rotated.

The Rod (23) carries two $\frac{3}{4}$ " Sprocket Wheels (53 and 54) which are engaged by Sprocket Chains connected to cords (55 and 56*). The cords (55) pass over 1" Pulley Wheels (57) and end Pulley Wheels (58, Fig. D) disposed horizontally, being finally connected to the Flat Brackets (59) on the trolley of the grab. Consequently as the Sprocket Wheel and Chain (53) is wound in one or other direction, according to the direction of rotation of the main driving Rod (19), so will the grab and its trolley be caused to travel in or out along the rails (3).

Simultaneous Action of Grab and Truck

Similarly the cords (56) from the other Sprocket pass over 1" Pulleys (60*), around 1" Pulleys (61), horizontally arranged, the ends of the cord being connected to Brackets (62) at each end of the truck (62, Fig. E). As the Sprocket Chains (53 and 54) rotate together, both the grab and the truck

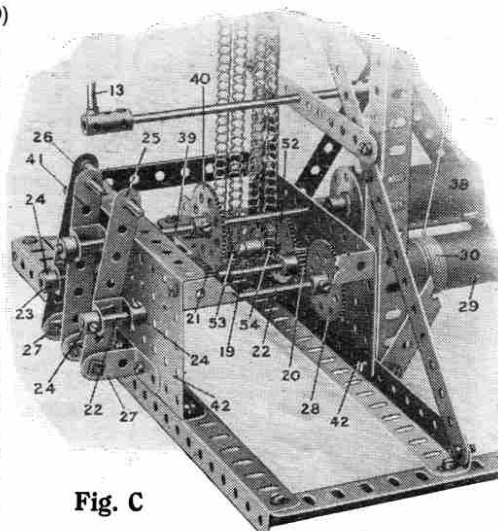

Fig. C

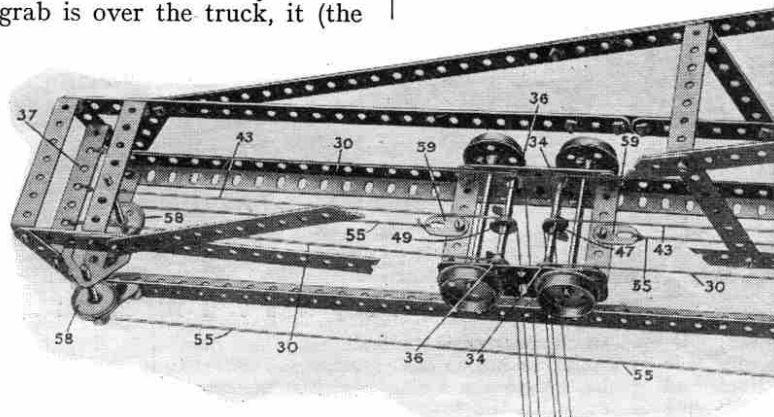

Fig. D

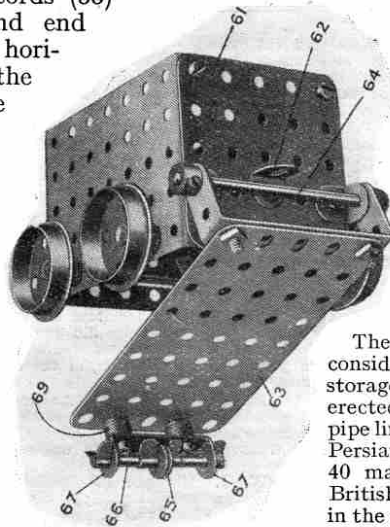

Fig. E

travel at the same time, but in order to ensure that they travel in opposite directions, so that they both move inwards or outwards together, the cords (56) are crossed before they pass over the Pulleys (60), while the cords (55) are left open.

As the truck approaches the outer end of its travel, it discharges its contents down the chute as previously mentioned. To enable this to take place, the bottom of the truck (63) is pivoted (as shown in Fig. E) on a 3" Rod (64). At the other end of the bottom Plate (63) is a $\frac{1}{2}$ " Pulley (65), carried on a $1\frac{1}{2}$ " Rod (66) mounted in a $1\frac{1}{2}$ " Double Angle Strip (67) secured to the base and spaced by five Washers (69).

In the centre of the rails (3) on the truck run-way a central Strip (68) is provided on which the $\frac{1}{2}$ " Pulley (65) runs. This Strip (68) is bent downward as it reaches the chute. Consequently, as the base of the truck reaches the chute, the wheel (65) rides down the bent end (68) and permits the bottom of the truck to open and the load to be discharged.

NEXT MONTH:

Another New Meccano Model TRACTOR

Advantages of Oil Fuel

The number of steamships burning oil fuel is already very large and it is increasing. Many up-to-date vessels are constructed to burn either coal or oil, this arrangement enabling their owners to take advantage of the state of the respective markets in the two fuels. As far back as 1904 the Admiralty were seriously considering the conversion of the Navy to oil fuel, and in 1912 Mr. Winston Churchill, then First Lord of the Admiralty, appointed a Royal Commission with Lord Fisher as president to consider the whole question of oil fuel and to advise the Government. After hearing evidence from all points of view, the Commission came to the conclusion that, assuming the necessary oil supplies could be assured, there would be no great risk in the conversion of the Navy from coal, and that whether there was risk or not the conversion would have to be undertaken. From that time onward the conversion proceeded rapidly, and to-day practically every ship in the Navy burns oil fuel.

The growing demand for oil fuel has necessitated considerable developments in all the principal docks. Huge storage tanks holding millions of gallons of oil have been erected at suitable points along the various docks, with pipe lines running to the points of bunkering. The Anglo-Persian Oil Co., for instance, have established more than 40 main bunkering installations on the shores of the British Isles, at the principal Continental ports, and also in the chief shipping centres of Asia, Africa and Australia. These installations, the number of which is continually being increased, comply with the two essential conditions of ample storage capacity and rapid delivery to ships.

*See illustration in last month's "M.M."

Sailing Without Sails

Discovery of 70 Years Ago Makes Rotor Ship Possible

RATHER more than 70 years ago Professor Magnus, a German, discovered that the propelling power of wind acting against rapidly-rotating cylinders was much greater than the power of the same wind when acting against a stationary surface, such as a sail. This discovery has been utilised recently in a most interesting manner by another German, Herr Anton Flettner, in what is known as the "Rotor Ship," a photograph of which we are able to reproduce here.

The Revolving Towers

The rotor ship is a vessel of 650 tons. Instead of the usual masts and sails, she is fitted with two towers, 50 ft. in height and 10 ft. in diameter, which look something like funnels with inverted saucers on the top. These towers are hollow cylinders extending to the bottom of the ship and revolving on pivots. Each cylinder is driven by a small motor of about 9 h.p. and can be run up to a speed of 120 revolutions per minute.

These revolving towers are really sails operating on sound scientific lines and taking advantage, not only of the driving pressure of the wind, but also of its suction. The suction behind a sail is actually more effective than the pushing force of the wind, but in the past this suction has been almost entirely ignored.

Controlling the Ship

Steering is effected by stopping the rotation of one of the towers, and the

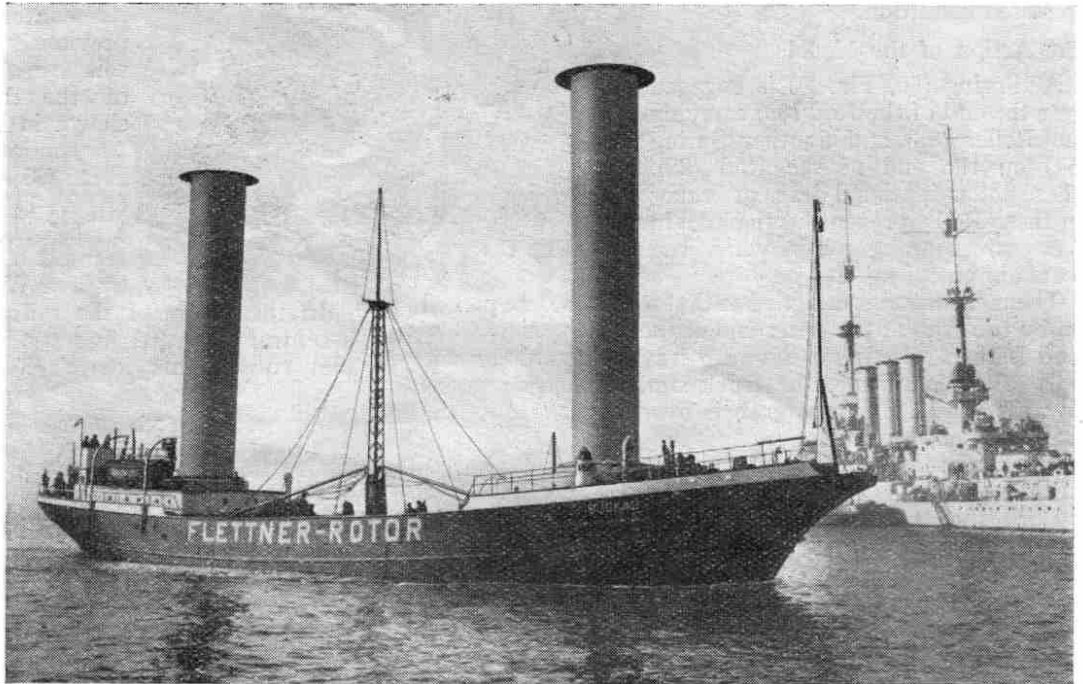

The Rotor Ship on a Trial Trip in Kiel Harbour

whole process is controlled by one man from the bridge of the vessel. This man has before him a dial indicating the speed at which the towers are turning, and by means of a control handle he is able to increase or decrease this speed or stop the rotation altogether. In this way one man performs the work of the crew required to handle a sailing ship of the ordinary type. The best record of the rotor ship so far is 8 knots with a wind blowing at the rate of from four to five miles per hour.

It is too soon yet to attempt to forecast the future of rotor-propelled ships, but it appears possible that they may have considerable value as cargo carriers. They will, of course, require to be fitted with some auxiliary motor power for use in calms and for working them into and out of harbour.

It is stated that a similar invention was patented some years ago by an Englishman, but no details are available at the moment.



BRIGHT IDEAS

These columns are reserved for dealing with suggestions sent in by Meccano users for new parts, new models, and new ways of making Meccano model-building attractive. We are always pleased to hear from any Meccano boy who has an idea which he considers will be useful in the Meccano system.

W. Wilson (Londonderry).—The inclusion of a smaller pinion than half-inch would not be practical, as it would depart from our half-inch standard.

L. Wedgewood (Newcastle).—Face plates, joined by double angle strips of the desired length, give a fairly good representation of a locomotive boiler.

S. Blake (Toronto).—Any gradient over $1\frac{1}{2}''$ in $12''$ is scarcely practicable with clockwork engines. Their light weight would be insufficient to ensure a grip on the rails. The present straight rails can be adapted to the above-mentioned gradient.

David Jones (Llanidloes).—The pipes above the buffers of trains are flexible tube couplings for the vacuum brakes. This item added to Hornby Trains would merely be ornamental and would serve no useful purpose.

R. Poincare (Lyons).—We think our regular spring, connected diagonally to two strips disposed at a right angle, would overcome your difficulty.

W. Menzies (Edinburgh).—The Meccano Shafting Standards will suit your purpose admirably. These standards are sold in two sizes, large and small (price 1/- and 8d. each respectively), and are obtainable from all Meccano dealers.

E. Capper (Northwich).—We already list a single crank shaft (No. 134). Connecting rods may be made from our standard rods with a coupling as connection.

J. Mason (Liverpool).—(1) To facilitate the recognition of the various parts we include illustrations in our price lists. (2) We should be interested to see a photograph, if you have one available, of the beam engine you have constructed.

J. Jardine (Adelaide, Australia).—(1) An interior toothed wheel would be too expensive to make and its advantages are somewhat doubtful. (2) We have the twisted or transverse strip already under consideration.

D. Grimwade—**W. J. Allardyce** (Cheltenham).—(1) We have recently introduced a pulley, 6" diameter similar in design to the 3" pulley. (2) We are considering the advisability of squaring the shoulder in the threaded pins for the purpose of obtaining a

firmer fastening. (3) We shall consider the matter of a worm wheel with a wider pitch.

E. Ray (Letchworth).—We are experimenting with a different type of propeller to the one we list.

I. N. Muir (Oshawa, Ont.).—Braced girders with bracketed ends may have uses in one or two instances, but in the great majority of cases they are not required. The part is more adaptable in its present form.

C. F. Marshall (Marlborough).—We quite appreciate the advantage of rods with pointed ends for minimising friction, but numerous difficulties would arise.

H. Harris (?).—Thanks for your clear sketch of suggested ball race for wheels of motor chassis. It appears to us to be somewhat unwieldy for this particular purpose. We shall examine the principle more closely and perhaps find a use for it in some other direction.

J. L. Tisshaw (Manor Park, E.).—Such a rod connection as you suggest is not practicable on account of the small diameter of the rod. In any case this principle would merely duplicate the functions of the coupling.

J. Schofield (London).—As an alternative to using a strip as a connecting rod, you could employ a rod with a coupling at either end, connection being made horizontally through the end hole in the coupling by means of a $\frac{3}{8}''$ bolt. One or two spacing washers on the bolt would ensure free action. This is an instance in which existing Meccano parts are adaptable where they obviate the introduction of special parts.

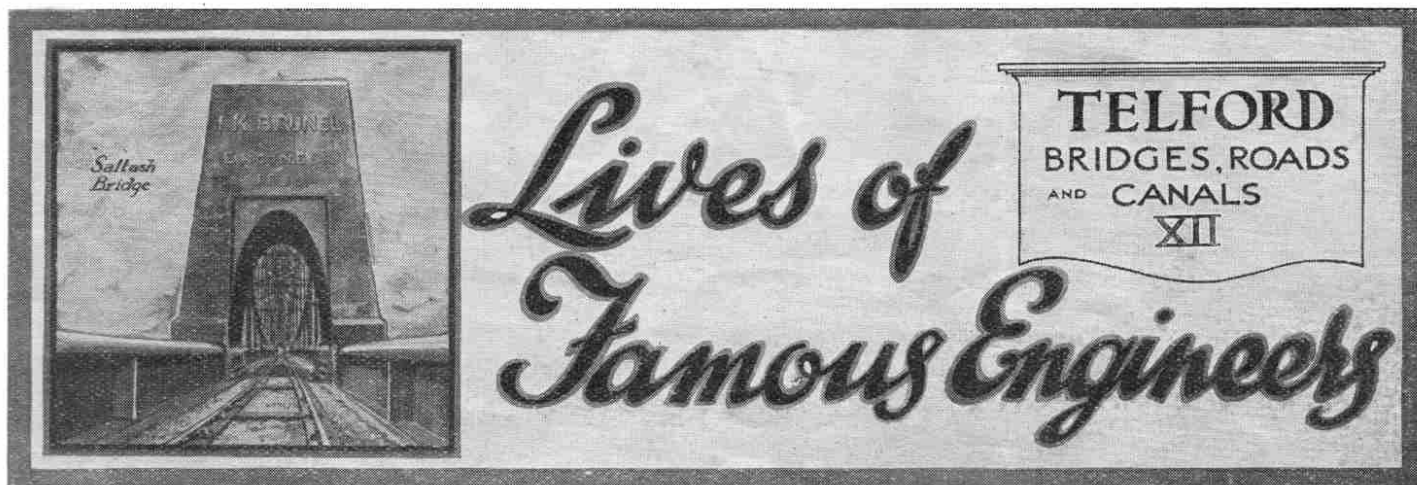

This month we conclude our story of the life of Telford with an account of his great work as a road maker and bridge builder. We show how he continued to carry out important engineering schemes almost up to his death, at the age of 77. Telford's career provides a wonderful lesson on the value of hard work, without which the greatest ability is of little use.

IN 1808, at the wish of the King of Sweden, Telford was consulted as to the best method of constructing the Gotha Canal from Lake Wenern to the Baltic Sea in order to complete communication with the North Sea. Telford visited Sweden, spent two months in surveying the district and prepared a report, which was immediately adopted.

Two years later he again visited Sweden to inspect the progress of the preliminary excavations. He supplied drawings for the various locks and bridges and, with the consent of the British Government, he provided the Swedish contractors with patterns of the latest tools and appliances used in canal construction. He also arranged for a number of expert English canal workers to go over to instruct the local workmen. The length of the canal was 55 miles and the total length of the navigation, including lakes, 120 miles. The locks were 120 ft. in length and 24 ft. in width, the width of the canal at the bottom being 42 ft., and the depth of water 10 ft. The Gotha Canal proved a great success, and in recognition of Telford's services the King of Sweden conferred upon him the Swedish order of knighthood and presented him with his portrait set in diamonds.

Improving Brindley's Canal

Telford next constructed or improved a number of canals in England. One of the most interesting of these works was the cutting of a new tunnel through Harecastle Hill to supplement the original tunnel on the Grand Trunk Canal built by

Brindley some 50 years earlier, and described in our issue of October last.

Brindley's tunnel had proved incapable of dealing with the greatly increased traffic. It only admitted the passage of one narrow boat at a time and all boats had to be propelled by the process called "legging"—that is to say, the men lay on the deck and forced the boat along by pressing with their feet against the sides or roof of the tunnel. This extraordinary process occupied about two hours, and on emerging from the tunnel the boatmen were utterly exhausted with their efforts. The Canal Company consulted Telford on the matter and he advised the construction of a new tunnel, parallel with the old one but on a much larger scale. The work was commenced in 1824 and was

completed in less than three years. When we remember that Brindley's smaller tunnel took 11 years to construct we realise the great improvement in engineering appliances that had taken place since his time.

The new tunnel was 2,926 yards in length, 16 ft. in height and 14 ft. in breadth. The "legging" process was abolished, and instead a tow path 4 ft. 9 in. in width was provided, along which horses hauled the boats in the ordinary way. The accuracy with which the tunnel was constructed is shown by the fact that it is so straight that its whole length may be seen through at one view, and although it was built by means of fifteen separate shafts sunk along the line it was to take, the joinings of the various sections of

brickwork are scarcely visible. Telford surveyed the tunnel a couple of years after its completion, and on this occasion he asked a boatman who was just bringing his boat through what he thought of it. "I only wish," replied the boatman, "that it reached all the way to Manchester!"

In December 1914 Telford's tunnel was brought up to-date by the introduction of an electric system of towage. It is also interesting to note that in 1848 a third tunnel was cut through this hill to carry the railway. This third tunnel is about seven yards above the level of the other two.

Telford also greatly improved another of Brindley's works, the Birmingham Canal, by doing away with many of the awkward bends, widening the waterway and cutting down the

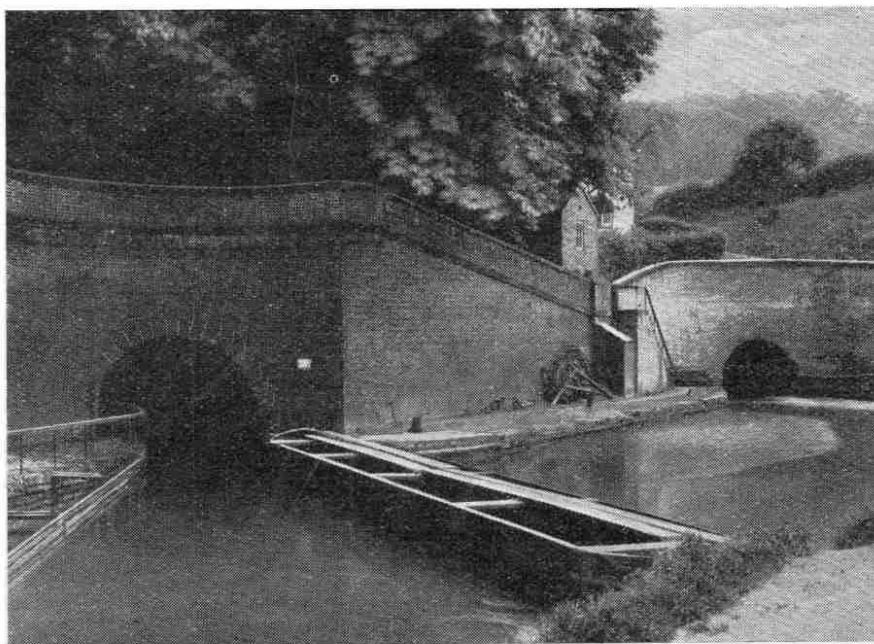
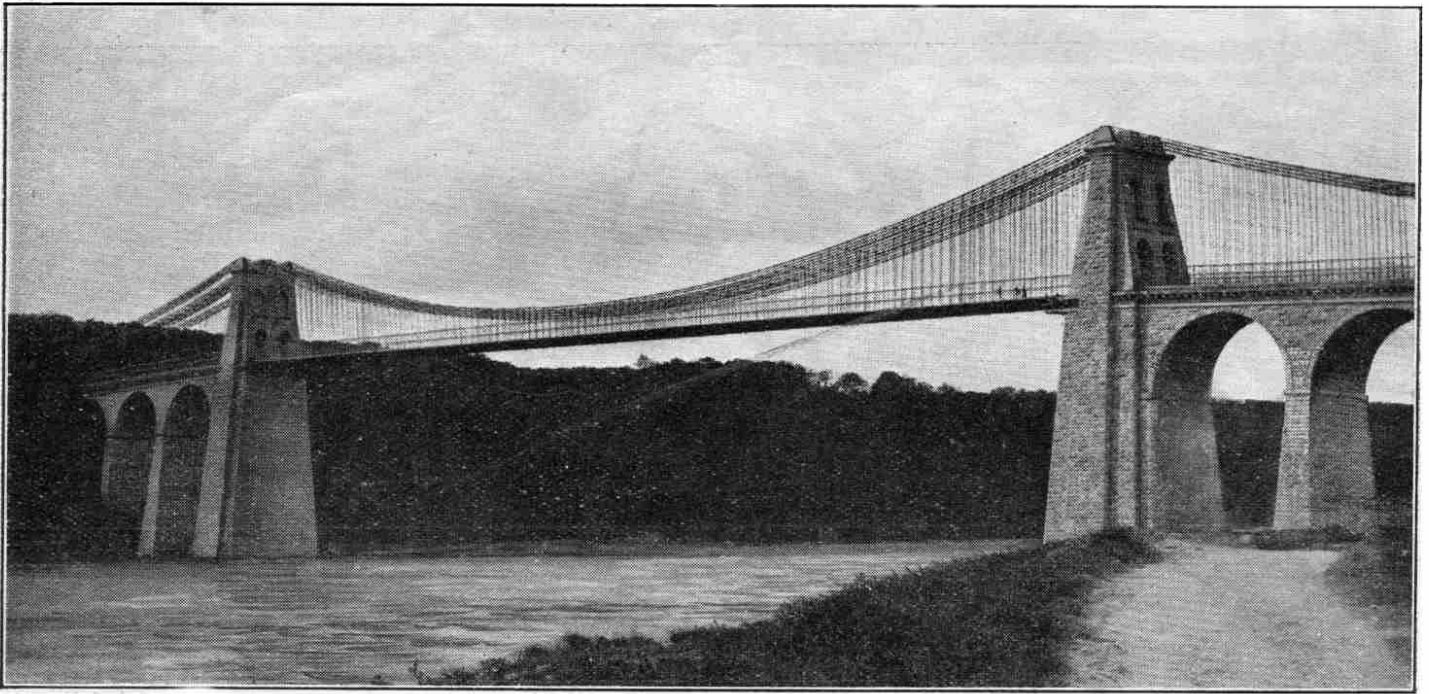

Photo courtesy]

Canal through Harecastle Hill.
Telford's Tunnel on left, Brindley's on right.

[L.M.S.R.]



The Menai Suspension Bridge

Lives of Famous Engineers

(continued from previous page)
 summit at Smethwick. Telford's last canal was the Birmingham and Liverpool Junction, which extended from the Birmingham Canal near Wolverhampton, via Market Drayton and Nantwich, and through Chester by the Ellesmere Canal to Ellesmere Port on the Mersey. This canal provided a second and shorter route between Birmingham and Liverpool.

Telford as Road-Maker

We must now turn to Telford's great work as a road-maker. At this period coaches were running between most of the chief towns of the country, but the longer journeys were difficult and slow on account of the extremely bad condition of the roads. This was especially the case with the highways connecting London with the chief towns of Scotland. In 1814 a Parliamentary Committee declared the road between Carlisle and Glasgow to be in such a bad state as to cause serious delay to the mails and danger to the lives of passengers. Some idea of the conditions may be gained from the fact that on one occasion a coach and horses actually fell through a certain bridge, this accident resulting in the death of the coachman and one passenger, while several other passengers were seriously injured. Local efforts to put the road in a fit condition having failed, it was decided to undertake its reconstruction as a work of national importance. Telford was placed in charge of operations and he constructed nearly 70 miles of new road of a quality not previously attained.

In this work Telford had two chief objects—to make the road as level as possible and to give it a surface capable of bearing without injury the heaviest weights likely to pass over it. He constructed the metal bed in two layers rising about four inches towards the centre of the road. The bottom layer was of stones seven inches in depth, set by hand with their broadest ends downward and cross-banded or jointed, no stone being more than three inches wide at the top. The

space between these stones was filled with smaller stones packed by hand so as to produce a firm and even surface. A drain leading to the outside ditch crossed beneath this layer every 100 yards. Upon this lower layer was laid a second layer, seven inches in depth, of hard stone broken small, and surmounted by a binding of gravel to the depth of about an inch. The result of this careful construction was a firm, hard, dry road, needing little in the way of repairs. The success of this road led to great activity in road repairing in various parts of the country, and Telford's services were in constant demand.

The Road to Holyhead

The most important road scheme carried out under Telford's immediate supervision was directed towards facilitating communication between London and Dublin by way of Holyhead. At that time this journey was a very serious undertaking involving considerable danger. On the Irish side there was nothing worthy of the name of a port, and after crossing the Irish Sea passengers were put ashore at Holyhead on the rough rocks, without any landing convenience! From there the road across Anglesey was merely a rough track. Accidents to coaches were of regular occurrence, and ultimately the London coachmen who had been brought to work this route refused to continue on account of the danger. On reaching the Menai Straits the unfortunate travellers had to cross in an open ferry boat, an unpleasant experience at the best of times and full of danger in bad weather, especially when the crossing was made at night. The next and final ordeal was the traversing of the Welsh roads, which were in a terrible condition and scarcely passable at all in winter.

With increasing traffic this state of affairs became intolerable and the Government at length took the matter in hand. The landings on both sides of the channel were improved, and in 1815 Telford was called upon to superintend the construction of a good coach road from Shrewsbury

to Holyhead. In this undertaking Telford followed the lines he had adopted in his Carlisle—Glasgow road. The mountainous character of the country made it extremely difficult to avoid steep gradients, but Telford grappled with the various obstacles so successfully that his road nowhere had a gradient of more than 1 in 20, whereas the old road in some places had gradients as steep as 1 in 6½. The most dangerous parts of the old road were dealt with first, and by 1819 the whole road was made safe and comparatively easy.

Select Committee's Tribute

Telford's splendid work in the construction of this road met with universal praise, and the Select Committee of the House of Commons reporting on the undertaking said:—"The professional execution of the new works upon this road greatly surpasses anything of the same kind in these countries. The science which has been displayed in giving the general line of the road a proper inclination through a country whose whole surface consists of a succession of rocks, bogs, ravines, rivers and precipices, reflects the greatest credit upon the engineer who has planned them; but perhaps a still greater degree of professional skill has been shown in the construction, or rather the building, of the road itself."

Bridging the Menai Straits

A good coach road was now provided all the way from Shrewsbury to Holyhead, but the crossing of the Menai Straits still had to be made in open boats, and after long consideration it was decided to employ Telford to construct a bridge across this dangerous ferry.

Such a bridge had been contemplated for many years. As early as 1776 a proposal was put forward for a great embankment with a bridge in the middle of it, and about nine years afterwards a scheme was proposed for a wooden bridge provided with drawbridges to allow the passage of shipping. Still later the famous engineer Rennie suggested a cast-iron bridge.

None of these schemes came to anything, however, and it was left for Telford to bring the project to completion. He put forward two proposals. The first was for a bridge at the Swilly Rock, to consist of three cast-iron arches of 260 ft. span, with a stone arch of 100 ft. span between each two iron arches for the purpose of resisting their lateral thrust. His second proposal, and the one that he himself favoured, was for a single cast-iron arch of 500 ft. span at Ynys-y-moch. Both plans were rejected, however, the second one largely on the ground that it would affect the navigation of the Straits.

Not long afterwards Telford was consulted as to the construction of a bridge over Runcorn Gap on the Mersey, and he recommended for the purpose a suspension bridge. He prepared a design and constructed a model of the central opening which successfully withstood the various strains that were applied to it. Although the scheme was never carried out, Telford's proposal drew public attention to the possibility of building bridges on the suspension principle.

Suspension Bridge Suggested

In 1818 Telford was instructed to make a further examination of the Straits. He again selected the Ynys-y-moch site and proposed a suspension bridge on the same lines as his Runcorn design. One great advantage of this scheme was that by spanning the whole channel between the low water lines and keeping the roadway 100 ft. above the highest spring tide level, no part of the navigable waterway would be obstructed. It was proposed that the distance between the main piers to carry the chains should be 550 ft. The main chains were to be sixteen in number, secured by masonry built over stone arches between each end of the supporting piers and the adjoining shore. Four of these arches were to be on the Anglesey side and three on the Carnarvon side. The roadway was to consist of two carriage-ways, each 12 ft. in width on each side of a 4 ft. footpath running along the centre of the mole.

Telford's plan was strongly supported by Rennie and other eminent engineers, and Parliamentary sanction for the scheme was obtained in 1819. Immediately this sanction was obtained Telford set to work. The preliminary operations were quickly carried out and early in 1820 building operations commenced. The three arches on the Carnarvonshire side and the four on the Anglesey side were undertaken first, and these were completed late in the autumn of 1824. The piers were 65 ft. in height from high water line to the springing of the arches, and the span of each was 52 ft.

While this work was in progress the two main piers, each 153 ft. in height, from which the main bridge chains were to be suspended, were also proceeded with. They were built with the utmost care in view of the enormous weight they would

have to carry. Over these piers were built the smaller arches to carry the roadway and upon these arches masonry was carried upward in tapering form to a height of 53 ft. above the level of the road.

The next step was to secure the land ends of the huge suspension chains, and this was accomplished in a very ingenious manner. The chains were taken underground down shafts about 20 yards in depth, then along a short connecting tunnel and up to the surface again through similar shafts. Thus, so long as the iron held, the chains could only come loose by tearing away a mass of solid rock 20 yards

means of blocks over the top of the Anglesey pier and from there to powerful capstans fixed on the Anglesey side. These ropes were manned by about 150 men who, when the signal was given, hauled steadily until the great chain was seen to be safely swinging in the air and the supporting raft was floating away. The most anxious moment was now passed, and a tremendous cheer broke from the enormous crowd that lined the shores on both sides of the Straits.

The remainder of the work was carried out quickly. In an hour and thirty-five minutes from the time that the hoisting

commenced, the chain was raised to its final position and securely fastened to the land portion that led to the Anglesey pier. Telford then ascended to the point of fastening and satisfied himself that a safe connection had been made, and the announcement of this fact was immediately followed by loud and prolonged cheering from the workmen, echoed in still greater volume by the spectators. Three of the workmen indeed were so excited that they scrambled from one side of the Straits to the other along the upper surface of the chain, which was only

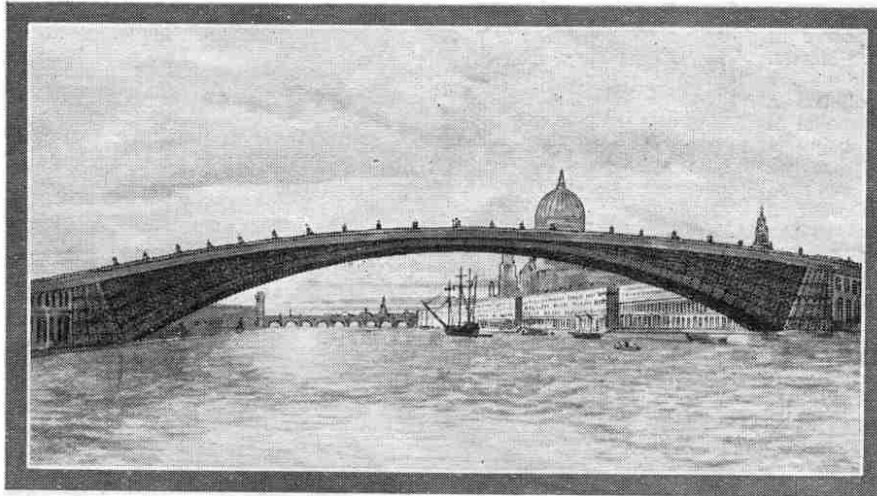

Telford's Proposed Single-Arched Bridge over the Thames

in depth. From their land anchorages the chains were led up to and over the top of the main supporting piers.

The chains were not actually attached to the supporting piers, but were carried over them on saddles or carriages of cast iron mounted on rollers so as to be free to move longitudinally upon the tops of the towers. The object of this arrangement was to allow for expansion or contraction with changes in temperature. Such changes affect bridges very considerably. An interesting example of this occurred during the construction of the suspension bridge over the gorge at Niagara Falls. In this case temperature changes had been allowed for by means of sliding mechanism, but in some way this mechanism became clogged with cement. The result was that the force of expansion due to a rise in temperature caused the massive supporting towers to be pushed out of position, and it was necessary to build entirely new towers.

Hoisting the Chains into Position

By the beginning of 1825 the suspension piers, land piers and arches and the land ends of the chains were all in position, and it now remained to suspend the main chains. Telford decided to carry this out by building the central portion of each chain on a raft 450 ft. in length and 6 ft. in width. This raft was to be floated into the proper position and then the chain lifted into place by means of capstans.

In April 1825 the raft bearing the first main chain was cast off from the Carnarvon side, towed by four boats into its position between the main piers and there moored. One end of the chain was then securely bolted to the end of the chain hanging from the Carnarvon pier, and the other end was attached by ropes passing by

nine inches in width!

The Bridge Completed

The construction of this bridge was a tremendous mental strain upon Telford. Many engineers had predicted its failure, and in spite of the minute care with which Telford supervised every detail of the work there was always the possibility of a flaw in the iron or the overlooking of some little detail that might cause disaster. For some time before the bridge was finally opened Telford's anxiety was so great that he could scarcely sleep, and when the result of the first day's experiment proved beyond doubt the strength and solidity of the bridge, Telford's friends who rushed to congratulate him found him on his knees engaged in prayer.

The remaining fifteen chains were suspended without any particular difficulty, and the final bolt of the last chain was fastened on the 9th July, 1825. On this occasion there was again an immense crowd along the shores of the Straits. A band, accommodated on a scaffolding built over the centre of the curved part of the chain, played the National Anthem amidst a storm of cheering, the workmen marched in procession along the bridge over a temporary platform, and a steamer passed beneath the chains and back again, thus re-opening the navigation of the Straits. The road platform, side railings and approach roads were rapidly completed and the bridge was formally opened for public traffic on the 30th January, 1826, when for the first time the London and Holyhead mail coach passed over it.

The total weight of iron used in the Menai bridge was 2,187 tons, in 33,265 pieces. The total length of the bridge was 1,710 ft., or nearly a third of a mile,

(Continued on page 30)

Our Dragline Competition

Results and Awards

THIS competition, which was announced in our August issue, followed a series of articles describing the heaviest Dragline in the world that appeared in our March and April issues. Messrs. Ruston & Hornsby Ltd., the makers of this great Dragline, offered a prize for the best Meccano model of their machine, the prize being a cheque for £5. To this prize we added two others—to be awarded to the second and third in order of merit—of Meccano products to the value of £3/3/- and £2/2/- respectively, to be chosen by the winners from the current Meccano catalogue.

Judging Competitions

The competition aroused considerable interest and there was a very large number of entries from all parts of the world. The majority were very excellent models, showing that the competitors had closely studied our article and the accompanying photographs. They showed also that the competitors thoroughly understood the constructive details of Draglines, and that they had grasped the principles on which they worked and the purposes for which they were used.

Although highly satisfactory from all points of view, the excellence of the models caused the judging of the entries to take longer than we anticipated, and we have not been able to announce the results of this contest until now.

The work entailed in judging a contest of this nature is very considerable, for every entry must be carefully examined and

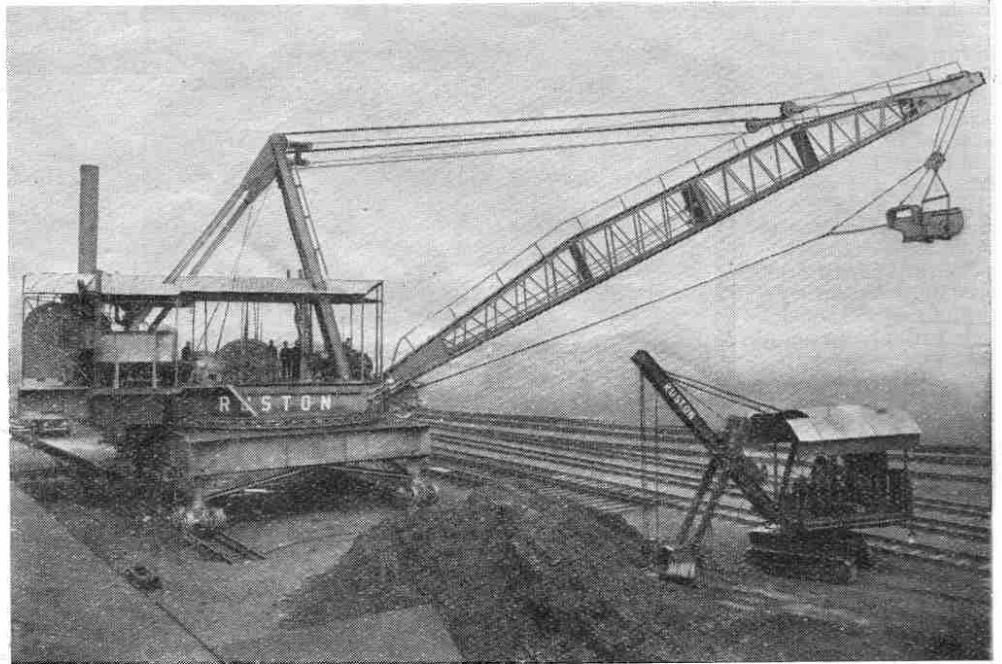

Photo courtesy]

[Messrs. Ruston & Hornsby Ltd.

The Largest Dragline in the World :

This was the original in this Model-Building Competition

the photographs or sketches closely investigated. When there are any points not clear, it is sometimes necessary for us to build up models ourselves to the competitor's specifications.

In judging Meccano models the two points that are given the greatest consideration are true engineering practice and closeness of design to the original. In this Dragline contest, for instance, one competitor lost points by showing a flight of steps leading from the ground to the rotating portion of the Dragline. This feature was not shown in the original structure nor was it a practicable addition, for it would result in the steps being completely sheered away the first time the Dragline was rotated on its base! Small points such as this are often overlooked by competitors, when, perhaps, at the last minute little details are added to improve the appearance of the model in the eyes of the competitor, or perhaps to use up a few odd parts.

The Prize Winners

We have pleasure in announcing that the First Prize of £5 has been awarded to J. H. Keightley, of Melbourne. The Second Prize, Meccano products to the value of three guineas, has been awarded to D. R. Heerama-neck, of Bombay, and the Third Prize, Meccano products to the value of two guineas, to M. Cavallini, of Rome.

Specially Commended

The following competitors have been highly commended by the judges and special certificates of merit have already been despatched to them.

Ainsworth, S. (Blackburn); Alexander, G. (Liverpool); Allnutt, P. L. (Australia); Auchinachie, A. G. (Kilwinning);

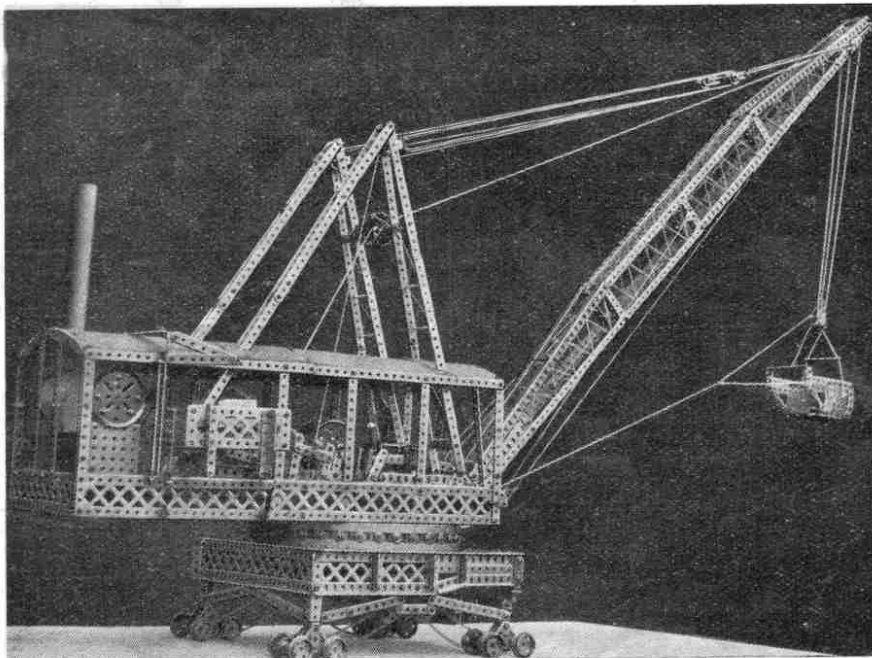

Awarded First Prize (£5) : J. D. Keightley, of Melbourne, Australia

Basanelli, E. (Italy); Baxendale, D. (Colwyn Bay); Begema, S. (Dutch East Indies); Bentley, A. (Bury); Blunt, P. (Woodville); Buchholtzer, C. (Roumania); Busoui, E. (Firenze); Chamber, W. (York); Chowdhury, A. N. R. (India); Coombes, M. (Ilminster); Cordwell, S. (Smethwick); Cowburn, W. K. (Balcombe); Davies, J. W. (Stourbridge); Dawler, S. (Wigan); Didsbury, S. (Lancaster); Field, T. B. (Forrest Row); Ford, R. M. (Northwood); Foster, J. L. (Cape Town); Gelsthorpe, C. (St. Grimsby); Harbard, G. (Slough); Hatcher, J. (Enfield); Henwood, G. (New Zealand); Hollyoak, L. (Coventry); Howell, R. L. (Knowle); Hurry, A. (Dunbar); Ireland, D. J. (London, W.13); Jones, E. (Nottingham).

enable those who wish to do so to follow its construction.

The Meccano Dragline

The general construction will be clear from the photograph. The details of the power plant and gearing are, briefly, these:—The speed of the motor driving the various working parts is reduced twice by means of two $\frac{1}{2}$ " Pinions and two 57-toothed Gear Wheels. On the shaft carrying the second reduction gear or main-driving shaft, is a 1" Gear Wheel, a $\frac{1}{2}$ " Pinion, and—at the extreme end of the shaft outside the housing—two $\frac{3}{4}$ " Sprocket Wheels.

The 1" Gear Wheel on this driving shaft engages with another 1" Gear Wheel, which carries on its shaft a Bevel Gear, a 57-toothed Gear Wheel, and another 1" Gear Wheel. This lay-shaft is so adjusted that the gears may be thrown into, or out of mesh as required. For example, to drive the model forward, the Bevel Gear is thrown into mesh

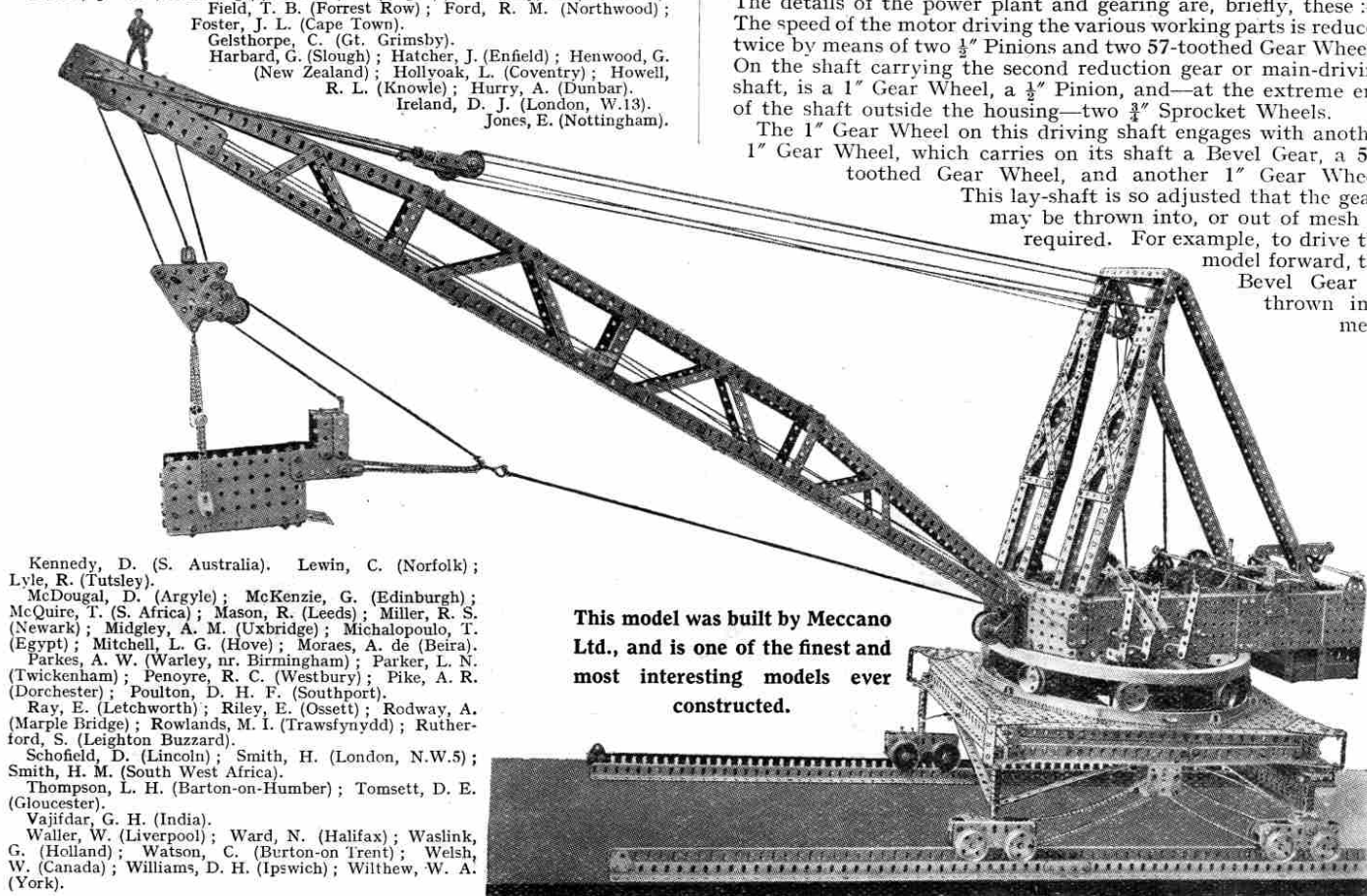

This model was built by Meccano Ltd., and is one of the finest and most interesting models ever constructed.

Kennedy, D. (S. Australia); Lewin, C. (Norfolk); Lyle, R. (Tutsley); McDougal, D. (Argyle); McKenzie, G. (Edinburgh); McQuire, T. (S. Africa); Mason, R. (Leeds); Miller, R. S. (Newark); Midgley, A. M. (Uxbridge); Michalopoulos, T. (Egypt); Mitchell, L. G. (Hove); Moraes, A. de (Beira); Parkes, A. W. (Warley, nr. Birmingham); Parker, L. N. (Twickenham); Penoyre, R. C. (Westbury); Pike, A. R. (Dorchester); Poulton, D. H. F. (Southport); Ray, E. (Letchworth); Riley, E. (Ossett); Rodway, A. (Marple Bridge); Rowlands, M. I. (Traffsnyydd); Rutherford, S. (Leighton Buzzard); Schofield, D. (Lincoln); Smith, H. (London, N.W.5); Smith, H. M. (South West Africa); Thompson, L. H. (Barton-on-Humber); Tomsett, D. E. (Gloucester); Vajifdar, G. H. (India); Waller, W. (Liverpool); Ward, N. (Halifax); Waslink, G. (Holland); Watson, C. (Burton-on-Trent); Welsh, W. (Canada); Williams, D. H. (Ipswich); Wilthew, W. A. (York).

A Splendid Model

The Dragline is such a splendid subject for a model that our Model-building department themselves constructed a model of it, and of this model we are able to publish a photograph. This special model—which, of course, was not eligible to compete for the prize—measures about 3 ft. in length and is complete in almost every essential detail, even down to the raising jacks for levelling the table on which the roller bearings support the jib and power house. A comparison of the model on this page with the illustration on the previous page, and with the detailed illustrations in our previous issues of March and April last, will show how faithfully the original has been copied in this model.

It should be here mentioned that no detailed instructions for building this Meccano model of the Dragline are available, but the following particulars will

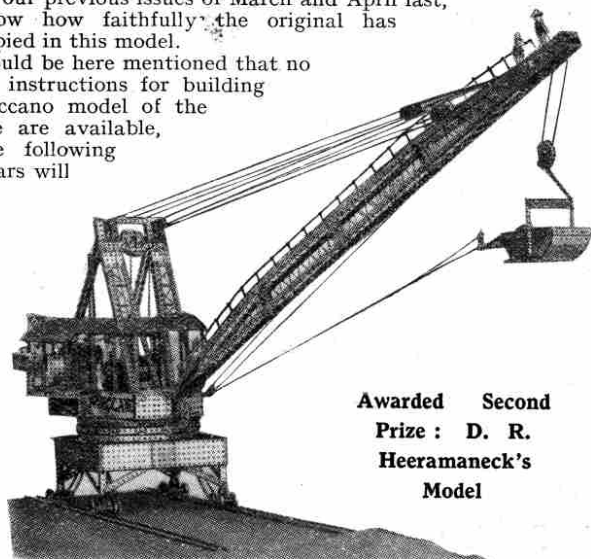

Awarded Second Prize: D. R. Heeramanek's Model

with another Bevel Gear. At the same time the 57-toothed Gear Wheel slips into mesh with the $\frac{1}{2}$ " Pinion on the main driving shaft. This is a third reduction of the motor, so that the model will not travel too fast along the rails.

The Bevel Gear, on meshing with the second Bevel Gear, turns a vertical Rod, on the bottom end of which is a $\frac{3}{4}$ " Sprocket Wheel, connected to a 3" Sprocket Wheel which is fastened to a Rod running down through the centre of the model, on the end of which is a Bevel Gear in permanent mesh with another, on a Rod, at each end of which is a $\frac{1}{2}$ " Pinion. This Pinion again is in mesh with two others on short Rods on each of which is a $\frac{3}{4}$ " Sprocket Wheel. These wheels are then connected by Sprocket Chain to the track wheels.

Operating the Mechanism

To rotate the drag arm and the housing throw across the lay shaft, which disengages the Bevel Wheels and the 57-toothed Gear Wheel with the $\frac{1}{2}$ " Pinion, and throws into mesh the 1" Gear Wheel with the 1" Gear Wheel on the main-driving shaft. At the same time the 1" Gear Wheel on the end of the lay shaft meshes with another 1" Gear Wheel on a short Rod. This Rod also carries a $\frac{1}{2}$ " Pinion, permanently in mesh with a 57-toothed Gear Wheel. On the same Rod is a Worm Wheel actuating a 57-toothed Gear Wheel on a vertical Rod, at the bottom of which is a 2" Sprocket Wheel in contact all the time with Sprocket Chain, itself so arranged around the circular track that it cannot move. The result is that as the Sprocket Wheel rotates, the drag-arm and housing are compelled to revolve. As the main-driving shaft is revolving all the time, so too are the two $\frac{3}{4}$ " Sprocket Wheels, on the end and outside the housing.

On the shaft of each of these is a $\frac{1}{2}$ " Pinion meshing with a 57-toothed Gear Wheel, each of which has another $\frac{1}{2}$ " Pinion on its shaft. These two Pinions work the three drums or Rollers that carry the cord for raising the drag-arm, for raising and lowering the drag, and for dragging the drag. Each of these Rollers is fitted with a 57-toothed Gear Wheel that may be thrown into mesh with the constantly-revolving Pinions by means of the levers at the side. To reverse the movement, reverse the motor.

HORNBY CLOCK WORK TRAINS

THE TRAINS
WITH THE
GUARANTEE



YOU can have any amount of fun playing with a Hornby Train. Shunting, coupling-up the rolling stock and making up trains will give you hours of pleasure. Hornby Trains are beautifully finished, strongly made, and will last for ever. One of their most valuable features is that all the parts are standardised, and any lost or damaged part may be replaced with a new one.

Every train is guaranteed, and you are therefore sure of satisfaction if you buy a Hornby.



No. 2 PULLMAN SET

No. 2 Pullman Set

The No. 2 Loco with Tender measures 17 in. in length. The Loco is fitted with superior mechanism and the accurately-cut gears ensure smooth running. Loco, Tender and Coaches are superb in appearance and finish, enamelled in colours and stoved at a high temperature to ensure durability. The Loco is fitted with reversing gear, brake and governor.

Gauge 0 in colours to represent the L.M.S. or L.N.E.R. Companies' rolling-stock. Each set contains Loco, Tender and two Coaches, with set of rails to form a circle of 4 ft. diameter. Price 60/-.

No. 1 Passenger Set

The Loco is fitted with reversing gear, brake and governor. Loco, Tender and Coaches are superb in appearance and finish, enamelled in colour and stoved at a high temperature to ensure durability. The doors of the Coaches open.

Gauge 0 in colours to represent the L.M.S. or L.N.E.R. Companies' rolling-stock. Each set contains Loco, Tender, two passenger coaches and set of rails consisting of two straights and curves to form a circle of 2 ft. diameter. Price 30/-



No. 1 PASSENGER SET

No. 1 Goods Set

Gauge 0 in colours to represent the L.M.S. or L.N.E.R. Companies' rolling-stock. Each Loco is fitted with reversing gear, brake and governor. Each set comprises Loco, Tender, one Wagon, and set of rails as in the No. 1 Passenger Set. Price 22/6

No. 1 Hornby Loco Price 15/-
" " Tender " 2/6

Hornby Passenger Coach Price 5/-
No. 1 Hornby Wagon " 2/6

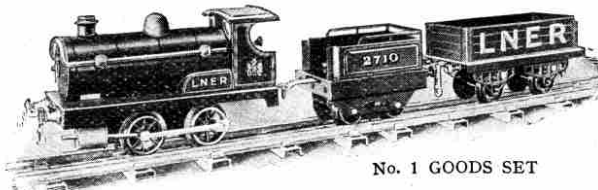

No. 1 GOODS SET

No. 2 Goods Set

Gauge 0 in colours to represent the L.M.S. or L.N.E.R. Companies' rolling stock. This set contains Loco, Tender and Rails as in the No. 2 Pullman Set, and two Wagons. Loco fitted with reversing gear, brake and governor. Price 37/6

No. 2 Hornby Loco ... Price 22/6
" " Tender " 3/6
Hornby Pullman or Dining Car ... Price 15/-
No. 2 Hornby Wagon " 2/6



No. 2 GOODS SET

Ask to see Sample Sets at your Toy Store
MECCANO LTD., BINNS ROAD, LIVERPOOL