

JULY 1925.

# MECCANO

## MAGAZINE

PRICE  
**3<sup>D</sup>**  
VOL. X  
Nº 7



*Famous Bridges (see page 322)*

# "Miss America"

## The World's best value in Steam Model Launches

### A BOY'S DELIGHT

Here's a tophole little launch which just buzzes through the water under her own steam. Thousands of boys are already having hours of delight with them on yacht pond or calm river. It is a three-guinea model for 12/6—beautifully finished, strong and well made.

**GOES 20 MINUTES  
AT ONE FILLING**

There is a real little engine and the new safety lamp raises a head of steam in very few minutes. A safety valve is fitted to the boiler and the oscillating cylinder turns the little twin bladed propeller to drive the boat 20 minutes at one filling.

**NOTHING LIKE IT FOR  
PRICE ANYWHERE**

"Miss America" is 2 ft. 6 ins. long, and has a 3½ ins. beam. She is finished off in three brilliant colours of enamel, and made to ride the water gracefully and easily. A tiller is provided so the boat can be steered, and a filler, lamp, and full instructions are supplied with each boat.

**12'6** Complete  
Postage abroad  
9d. extra.

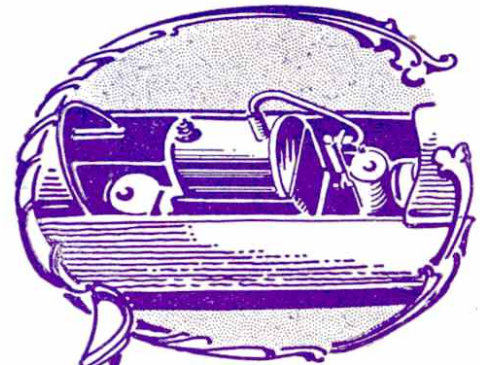

**Free to Meccano Readers**

A short pamphlet giving full details of the launch will be sent to any reader who sends a post-card for one to Department 960.

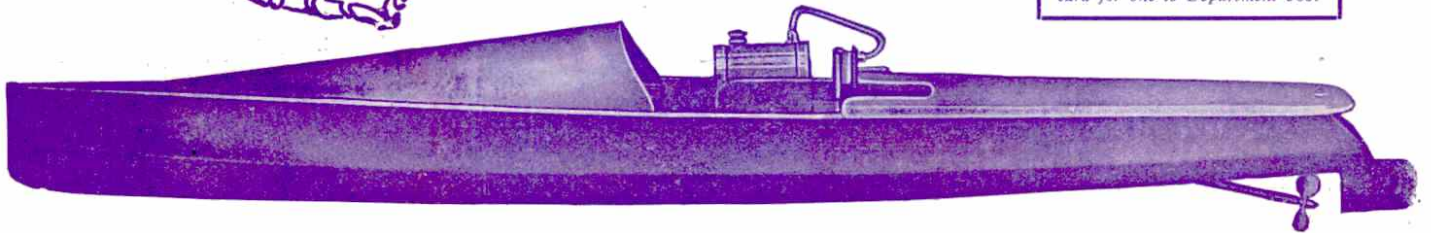

**WHERE  
YOU CAN  
BUY THEM**

**Hobbies Ltd. (Miss America Department), Dereham, Norfolk**

Or from Hobbies Branches at London, Glasgow, Manchester, Birmingham, Leeds, Southampton, Brighton or Sheffield. From most good stores and sports houses and the usual Hobbies Agencies. Also at 45, Colborne St., Toronto, Canada.

EDITORIAL OFFICE

Binns Road,

LIVERPOOL

Vol X, No. 7.



PUBLISHED

IN THE INTERESTS  
OF BOYS

July 1925

## With the Editor

### Five Generations

In writing about "Our Million Ancestors" on this page in the May "M.M." I mentioned how quickly the number of our ancestors adds up with every previous generation we take into account. In this connection I see that Sir James Barr, the famous specialist, recently stated in an interview, that in the tenth generation we each have 1,024 tenth grandparents.

On the same day, in another newspaper, I read that a baby boy has been born who is the latest of five living generations. He is the son of a farmer who lives on the wild moors near Slaiburn, in the heart of the Yorkshire hills. The boy has four grandparents, two great-grandparents, and one great-great-grandfather. In this family, therefore, there are five generations now living and the boy has nine living ancestors. This surely must be a record, but if any of my 50,000 readers can beat it, I should be glad to hear from them.

### Excavations at Abraham's Birthplace

Interesting discoveries have recently been made in Mesopotamia, on the site of Ur of the Chaldees, an ancient city where Abraham was born. For over fifty years excavating has gone on in this place, with numerous interruptions, from one cause or another. Since the War, however, the work has been carried on more regularly and with greater energy. Many wonderful discoveries have been made, including the foundation of a great tower dedicated to the Moon God and built over 4,000 years ago. A more recent temple, built 650 B.C. and dedicated to the wife of the Moon God, was restored by Nebuchadnezzar.

It was underneath the floor of this latter temple that some ancient records of great interest were found. In those days paper and even vellum was not used for writing, which is perhaps fortunate for had it been in use many ancient records could not have remained for us to read. Instead, clay tablets were used and the letters or hieroglyphics marked on them when soft with a stylus or sharp pointed instrument. Then the inscribed tablets were baked, so that they became similar to tiles. By these means the inscriptions on the tablets have been preserved through all the twenty-five centuries that have elapsed since they were inscribed.

### A Great Engineer of 4,000 Years Ago

The most important discovery yet made in this region of ancient Babylon, however, is that of five pieces of carved limestone. On being fitted together these form a slab of carved stone about 15 ft. x 5 ft. on which are pictures and records of King Ur-Engur, the builder of the great tower to the Moon God. The carvings on the stone show many scenes from the King's life and it is at once evident that King Ur-Engur was a great engineer. Among other exploits he is depicted superintending the digging of great canals to irrigate the ground, and building the great tower already mentioned. From the carvings it appears that the King did this because of a dream, in which the Moon God appeared to him and ordered him to erect the tower. The carved stone shows many other interesting scenes, including files of prisoners, and the soldiers of forty-two centuries ago beating their drums identically as they do to-day!

These discoveries are perhaps even more wonderful than those that have recently been made elsewhere, and which have previously been mentioned in these pages. I hope that the expedition now in Babylon will give us many more interesting items of research into the past, and as the ancient people of Ur were engineers of

no mean order we may look forward with particular interest to learning more of their achievements in this direction.

### An Index for the "M.M."

For some time past I have felt that the "M.M." had grown to such proportions as to make a paged list of contents useful, if not absolutely necessary. This month, therefore, I am introducing this feature, which will be found at the foot of the third column on page 376. In future, this list of the main contents will appear each month in the same position.

While on this subject I may mention that I am having an index to the year's issue prepared and this, together with a suitable title page, will be ready early in December. This will be good news to those numerous readers who use the special binding case supplied, or who have their "M.M.'s" bound at the end of the year.

### Result of "Inventors Essay" Contest

The "Inventors Essay" Contest, announced on this page in the March issue, drew an unexpectedly large number of entries, which showed that a good deal of hard work had been done by the entrants. One of the commonest weaknesses shown by competitors, however, was that of failing to grasp the really important things accomplished by each of the great men about whom they had to write. In many cases comparatively unimportant things were put forward prominently in connection with a certain man, whereas the one or two great things, for which he will be remembered for all time, were either passed lightly over or omitted altogether. In some cases, too, competitors showed carelessness in selecting different men from those intended. Thus, while some correctly wrote about Benjamin Franklin, others dealt with Sir John Franklin, although the latter was essentially an Arctic explorer and not an inventor or scientist. Some entrants were more cautious, however, as is illustrated by the fact that although Alexander Graham Bell, the inventor of the telephone, was undoubtedly the most famous of all inventors named Bell, one competitor found no less than three famous men of the name of Bell and wrote at length about each, so as to be on the safe side!

After considering the entries from every point of view, I decided to award the prize of a guinea to C. McCaig, of Willaston. Although this competitor's work was undoubtedly the best submitted, that of two other competitors showed considerable merit and I have therefore decided to award consolation prizes of special pocket wallets to W. E. Andrew (Grove Park, London, S.E.12) and E. H. Billing (Market Harborough).

### Our Special Railway Centenary Issue

As mentioned last month a special Centenary Number of the "M.M." will be published in September. Not only will it contain a special article giving a full description of the Centenary celebrations at Darlington, but it will be a special "railway number," in every sense of the word. There will be articles on different types of locomotives, instructions how to make a model railway station, description of the new series of 2-6-4 tank locos recently built for the Metropolitan Railway, an article on the fastest train in Britain, and an article from the pen of the Rt. Hon. J. H. Thomas, M.P., "Drivers Who Love Their Engines." Further particulars will be announced next month.

The number of copies of the special Centenary Number printed will be limited and all readers who have not already done so are advised to place an order at once with their Meccano dealer or newsagent for a copy to be reserved for them.

FAMOUS BRIDGES—No. 3

# BROOKLYN BRIDGE

## The First Large Suspension Bridge

**T**HE East River, separating New York from Brooklyn, is crossed by three of the greatest suspension bridges in existence—the Brooklyn, Manhattan, and the Williamsburgh Bridges, each of which has a fascinating story from an engineering point of view. Of the three, the Brooklyn Bridge, which is the subject of our cover this month, was the first to be built.

### A Pioneer of Wire-rope Making

At the time when the construction of the Brooklyn Bridge was first contemplated, the only means of crossing between New York and the mainland was by ferry boat. In the early eighties, however, the increased traffic between New York and Brooklyn necessitated the introduction of some other means of crossing the river.

Time after time suggestions for various types of bridges had been put forward, but all had been rejected because they were considered impracticable. The East River was both deep and wide and was always so busy with shipping that it was realised that it would be impossible to employ piers on which to rest the girders of any bridge. A single span of so great a width was at that time unheard of, and the construction of a bridge across the East River seemed to be an impossible proposition to put before any engineer.

At last, however, a suspension bridge was suggested by an engineer, who already had considerable experience in this type of structure. The man who launched this daring scheme to bridge the East River was John Augustus Roebling. He was born in 1806 at Mühlhausen in Prussia. He emigrated to the United States in 1831 and ten years later erected a wire-rope works at Pittsburg. He was one of the pioneers of wire-rope making, and to-day the firm he founded is one of the largest wire-rope makers in the world.

He was the first to use the suspension principle in America to support aqueducts for canals. His first suspension bridge, over the River Ohio at Cincinnati, had a length of 1,057 ft. and a height

of 103 ft. above the river. It was commenced in 1856 but the American Civil War stopped the work, and the bridge was not opened until 1867. In the meantime Roebling had completed a

series of experiments, and his fellow engineers of the day, who prophesied only failure and disaster for any bridge built on the suspension principle.

Roebling was a stubborn man, however, and he had full confidence in himself and finally his results themselves proved that his idea of making great bridges with wire was not only possible but also that it was by no means a complicated or difficult matter. Then, and then only, the theory that he had striven so hard to maintain was endorsed by boards of noted engineers and acclaimed by the public. He had had to fight his battles single handed, but in the end his confidence in himself was justified and he came out of the ordeal "on top."

Roebling's death was a terrible tragedy, all the more so for it came just as he had reached the summit of his fame. It occurred in 1869, while the great engineer was inspecting the site for one of the towers. The docking of his boat was bungled by the crew with the result that one of Roebling's feet was crushed between the quay-side and the boat, and although the accident was comparatively slight, complications arose that proved fatal.

Roebling did not live to see the wonderful structure his imagination had created, but it has been truly said that his name is woven into the very

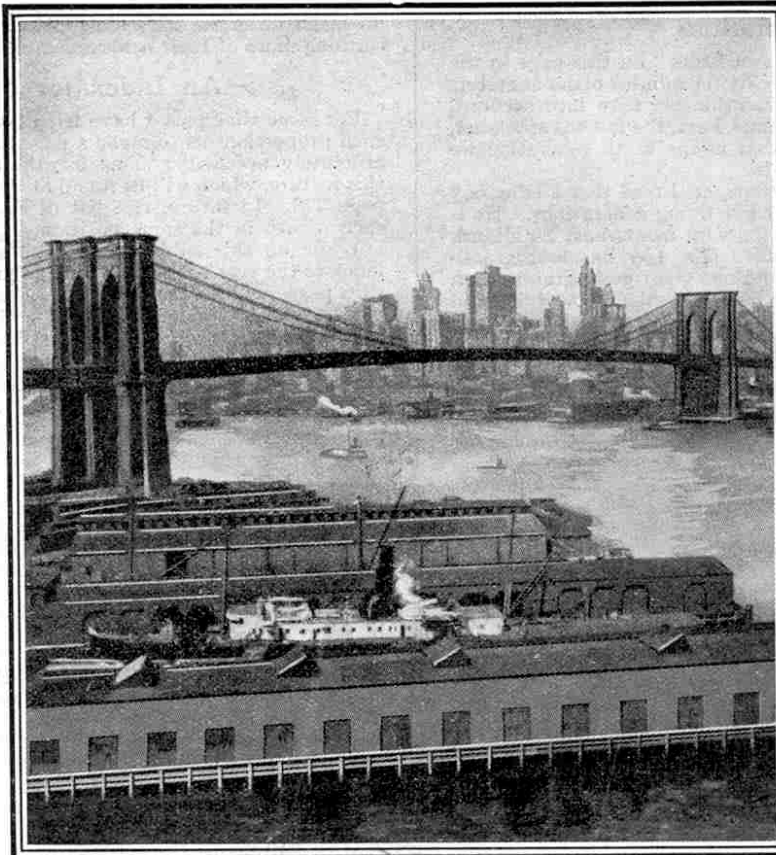

Photo]

[S.I.B.]

### The Brooklyn Bridge across the East River

wire rope bridge across the Niagara Falls, and another at Pittsburg across the Alleghany River.

### Roebling's Tragic Death

In his early days Roebling's experience in regard to wire rope bridges was similar to the experience of George Stephenson in regard to railways. Every hand seemed to be against him. His methods and plans were condemned by the leading

steel of the cables.

### His Son Continues the Work

It was a great triumph for Roebling when his plans for the Brooklyn Bridge were accepted in 1867. In May of the same year he was appointed engineer and authorised to proceed with the work. Although he died whilst the bridge was under construction, the work was not allowed to stop, for his son, Washington Augustus, determined to carry out his father's plans.

The actual work did not commence until 1870, but from that time onward until the bridge was completed there was no rest. Washington Roebling lived on the bridge, and under his supervision the massive masonry towers were gradually erected. Old buildings,

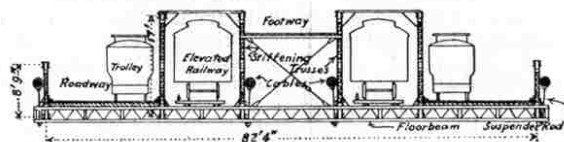

Fig 1. Cross-section of Brooklyn Bridge showing the two roadways, elevated footway, two electric car tracks and two elevated railways

landmarks of ancient New York, were pulled down and the ground cleared for the approaches. Over six years was required for the construction of the approaches and masonry piers and when at last the towers were completed, there remained the gap across the river to be spanned.

This was accomplished by a boat taking a  $\frac{3}{4}$  in. wire rope from the Brooklyn side to the New York shore, where it was passed over the tower and allowed to drop to the level of the river. Then, at a moment when the channel was free from shipping, the free end was carried across and drawn tight. A second rope was similarly suspended and having been joined to the first, was run over huge pulleys at either end, so that the two together formed an endless belt. To this was fixed a travelling platform, which was moved from one side of the river to the other by steam power.

**Contraction and Expansion**

These travelling ropes having been fixed, the spinning of the great cables commenced. The wire in each skein of these cables is nearly 200 miles in length and it is not surprising to find that seven years were required to complete the spinning of the cables.

One of the greatest difficulties encountered in this work was the contraction and expansion of the wires, caused by the variation in temperature of the atmosphere. It was very necessary that the wires should all be secured in uniform weather, for every degree of difference in the temperature caused a corresponding deflection in the slack of the cables of  $\frac{1}{8}$  inch.

At last, however, the great cables were in position and then the roadway itself was built. In 1883, the great day came when the President and the Governor and many other officials attended the opening ceremony, and the work, commenced 13 years before, had its realisation in this, the greatest bridge of its time.

**Dimensions of the Bridge**

The Bridge has a total length of 5,989 ft. or rather over a mile and a furlong. The central span between the two towers over which the suspension cables hang, is 1,959 ft. in length. The two shore spans from the towers to the anchor-

ages are 930 ft. in length and the approach viaduct on the New York side is 1,562  $\frac{1}{2}$  ft. in length and on the Brooklyn side 971 ft.

The suspension towers, which are massively built of masonry and stand on

The cables have a dip of 128 ft. in the centre of the large span and they rest on moveable saddles at the top of the towers (see Fig. 2). These saddles allow for slight movements of expansion and contraction in the cables, due to changes of temperature and alterations in load.

The cables are anchored at each end by massive masonry built on the shore, and supplementary cables, extending fan-like on each side of the towers, assist in supporting the shore spans and the portion of the long span roadway nearest the towers. They also brace the roadway and reduce its deflection under heavy loads.

**The Seven Divisions**

The roadway of the Bridge is 82 ft. 4 in. in width and is separated into seven divisions.

The centre track forms a footway and is 15  $\frac{1}{2}$  ft. in width and is raised 12 ft. above the level of the bridge. On each side of the footway are the rails of an elevated railway and on each side of these tracks are roadways 19 ft. in width, each of which has a trolley car track and a road for vehicles.

The Bridge thus carries two roadways, two trolley-car tracks, two railway tracks, and an elevated footway.

Opened in 1883, the Bridge remained by far the largest span in the world for seven years. It was deprived of its proud position in 1890 by the Forth Bridge, two spans of which exceed the large span of the Brooklyn bridge by 115 ft.

The Brooklyn Bridge, as is the case with most suspension bridges, is a graceful structure. It cost about £3,100,000 or about three times the original estimate.

**Effects of Modern Traffic**

When the bridge was built it was not expected that it would be required to carry the heavy railway rolling stock and electric cars of to-day, and consequently it was not constructed to withstand so great a strain of modern traffic.

Thus it is not surprising that in 1901 several of the short rods suspending the trusses from the cables were found to have snapped. It was then decided that the bridge needed strengthening in all its details.

This work was successfully carried out and the bridge to-day is as strong as ever and likely to remain in use for many years, if no accident occurs to it.



Reproduced by permission from

["Engineering for our Boys"]

The Suspension Bridge, from the Brooklyn Shore, with New York "Sky-Scrapers" in the distance

two piers built on the solid rock, rise to a height of 272 ft. They extend for 78 ft. below high water level so that they measure 350 ft. from the foundation to the top.

There is a clear headway of 135 ft. between the centre of the bridge and the river, and of 118 ft. near the piers at high water, so that vessels can freely pass beneath.

**Details of the Suspension Cables**

The four cables each contain 5,296 galvanised steel wires, placed side by side and untwisted. The cables were formed in this manner in preference to the usual method of twisting the wires together, as unbent and untwisted wire has a greater resistance than wire that is twisted. The wires are laid as close together as possible and arranged in nineteen strands, each of which is bound up with thick wire. Each cable has a diameter of 15  $\frac{1}{2}$  in. and a breaking strain of 12,000 tons.

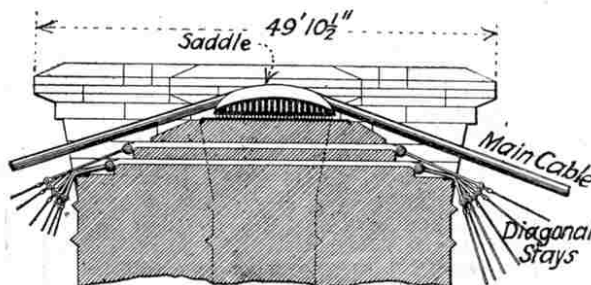
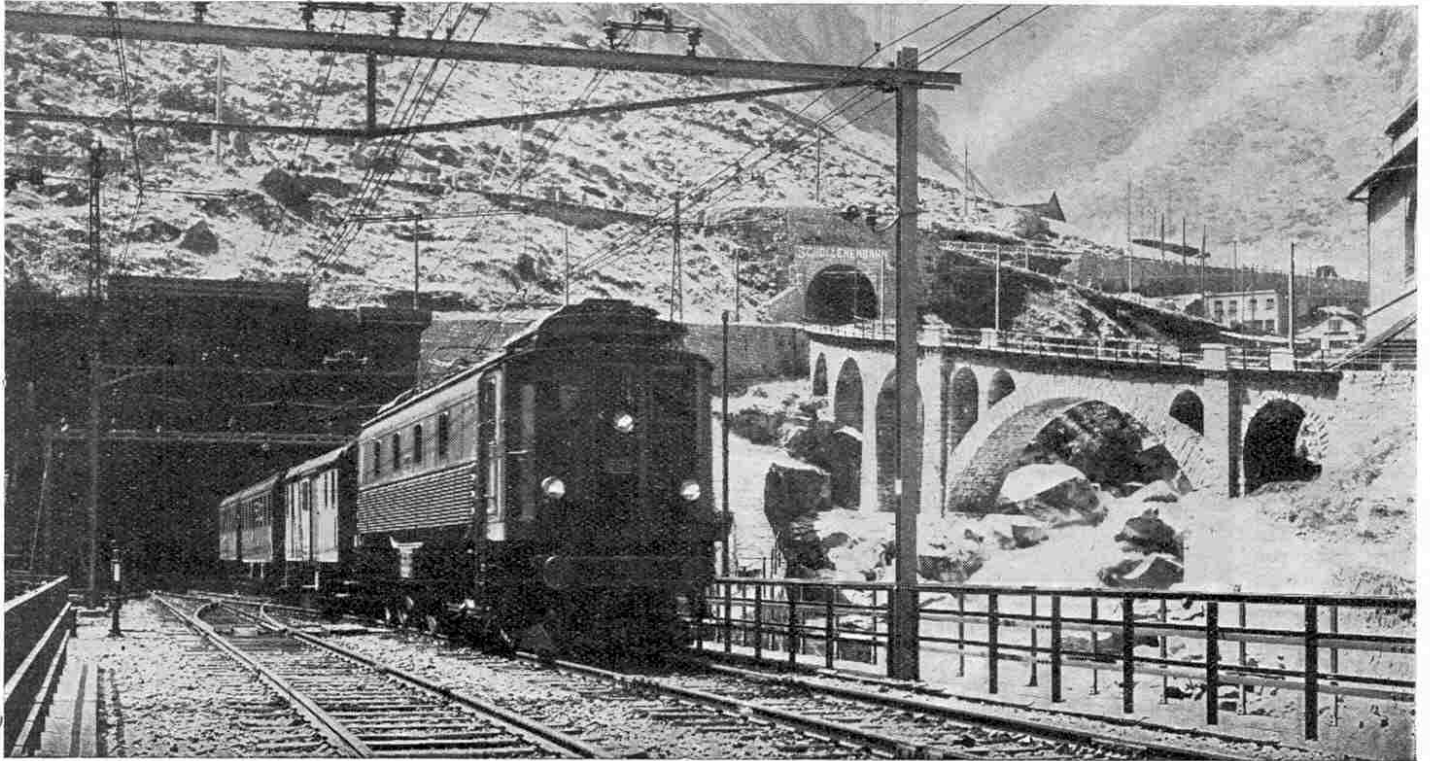

Fig. 2. Section of the top of one of the towers, showing saddle over which the main cable passes\* (\*Figs. 1 and 2 are reproduced, by permission of the publishers, from the Editor's book "Engineering for Boys")

# SWISS, FRENCH AND ENGLISH RAILWAYS COMPARED

By H. E. Underwood



[Photo]

Northern Entrance to the St. Gothard Tunnel, at Göschenen

[Swiss Federal Railways]

AS is the case with the inhabitants, the railways of the various countries of the world all have certain distinguishing features, and it is always interesting to compare foreign locomotives, rolling-stock and methods of working with those of our own railways. The following article deals with the more interesting and important points of difference between British railways and those of France and Switzerland.

## Railway Organisation

First of all, there is the difference in the organisation of the respective railways. In Great Britain and France the lines are owned by various private companies, but in Switzerland the railways for the most part are owned by the State. For this reason they are called the Swiss Federal Railways, which name includes practically all the main lines and a large number of the branch lines also. On the other hand,

the Swiss mountain lines—"funiculars" as some of them are called—are owned by various companies, and they form an interesting class quite apart from the ordinary railways. Mountain railways were briefly described in last month's "M.M." and we have another article in preparation.

In France there are six railway systems—Nord, from Paris to Calais and Belgium; Est, Paris to Germany and Basel; P.L.M. (Paris—Lyons—Méditerranée), Paris to Lyons, Marseilles, the Riviera, Italy and Switzerland; Paris—Orleans, Paris to Bordeaux and Nantes; Etat, Paris to Bordeaux, Brest and Dieppe; and Midi, lines at the foot of the Pyrenees, centred round Bordeaux and Toulouse.

Of these lines only one, the Etat, is owned by the State, and all of them except the Midi have one or more terminal stations in Paris. (Incidentally it may be mentioned that the locos and rolling-stock of the Hornby Trains in France are lettered to correspond with either the P.L.M., Nord or Etat lines).

## The Track

Turning now to the technical and mechanical differences between the railways of the three countries, we will deal first with the track itself.

In England and on the Etat, Orleans, and Midi railways of France, double-headed rails are fitted in chairs and held in

position by wooden blocks. In all other countries a rail of Vignole type is secured to the sleeper by means of a spike driven on each side, bolts being used instead of spikes in the case of metal sleepers.

The main lines generally have two tracks in France and in Switzerland, although this is less frequently the case in the latter. Local lines in both countries are always single-track. Four-track lines, which are so common on main lines in England, do not exist in Switzerland. In France they are to be found only on a few main lines for a short distance out of Paris. The standard gauge of the Swiss and French Railways is 1.435 metres, slightly over 4 ft. 9 in., as compared with the British gauge of 4 ft. 8½ ins.

## Stations

Stations in France and Switzerland differ in many respects from those in

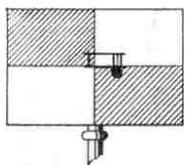

Home

French Signals

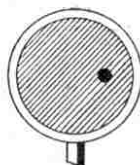

Distant

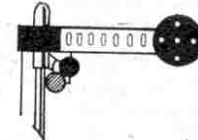

Home

Swiss Signals

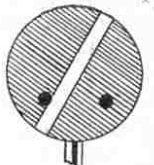

Distant

England, the most noticeable difference being in regard to the platform. In France and Switzerland, and in fact in nearly every country in the world except England, the platform consists of a simple pavement raised only a few inches above the level of the track. Such a thing as stepping directly from the platform into the carriage is a luxury known only in this country and on certain electrified lines in the United States. In nearly all other countries boarding a train or leaving it is a matter of climbing up or down, as the case may be!

Another point to be noted is that all Swiss stations are "open"—that is to say, entrance is free, the tickets being examined in the trains. In England and France, and in many other countries also, the stations are closed and tickets are punched or collected at the station entrance or exit. In such a case, entrance to the stations is confined to passengers, the booking hall being situated outside the control gate. In many cases, as in this country, friends seeing passengers off, or meeting trains, are allowed on the platform on production of a "platform ticket," which is obtainable for a small sum (one penny in this country) either at the booking office or from an automatic machine near the station entrance.

Swiss stations are generally built to conform to the style of their surroundings. In the mountain districts they are mostly designed on the lines of the neighbouring "chalets." In the cities, however, they are planned on lines in keeping with the other public buildings, and compare favourably in architectural beauty with the stations of any other country. The stations of Lausanne, Bienne, Basel, Lucerne, and Thoune are specially fine buildings.

In France the station buildings, with the exception of those in and around Paris, are as a rule unsatisfactory and frequently not too clean.

**Signalling Methods**

The signalling methods adopted on the various railways are as interesting as they are important.

In Switzerland the system does not differ a great deal from that in use in England. The "home" signals are of the semaphore type, but for "distant" signals green discs are used, which face the track to indicate "danger" and are turned face upward for "line clear." At night two green lights are shown for "danger" and two white lights for "line clear." The "home" signals show one red or one green light respectively for danger or safety. There are also specially-shaped signals, coloured blue, for controlling shunting movements.

French signalling is more complicated, but judging from the number of accidents on French railways it does not appear to be any more satisfactory than the English or Swiss systems. On French lines a distinction is made between signals for block-

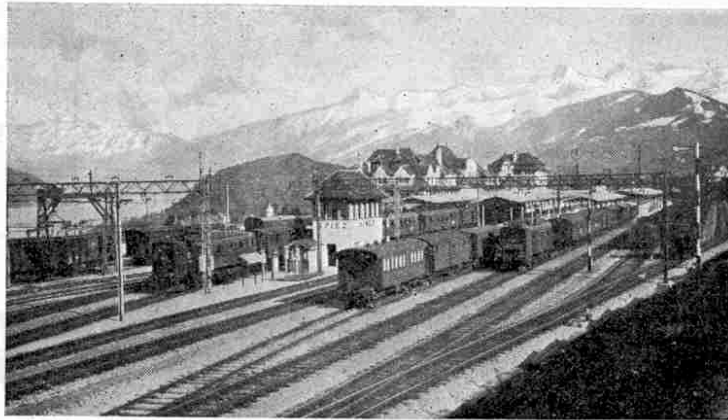

Photo

**Spiez Station, an important Junction**

[S. Anstetter, Thoune]

An electric locomotive of the Lötschberg Railway is seen on the left, near the signal box, and a signal, seen from the back, to the right.

track. There are, of course, other types of signals in France, mostly discs coloured green, blue or yellow, but those just described are the most important.



Photo

**Kandersteg Station in Winter**

[G. Schnetter, Thoune]

ment of work. To show how greatly the adoption of improved machinery had speeded up the work it may be mentioned that

sectioning and those for what is called "station protection." The first class of signals take the form of semaphores rather similar to English "home" signals. These are used only between stations for block-sections. The other signals are placed at all points requiring special protection—junctions, stations, etc.—and they are used also as "starting" signals. They are known as "carrés," the name being derived from their peculiar form, which is that of a flat square plate divided into four equal parts, which are coloured alternately red and white. The "distant" signal is a disc as in Switzerland, but the French signal indicates "line clear" when the face is parallel to the track.

**Tunnels and Bridges**

As is only to be expected in a mountainous country, tunnels and bridges occur very frequently on Swiss lines, and are often on a larger scale than those of England or France. The most noted are the three great Alpine tunnels—the Simplon (12½ miles in length), the St. Gothard (9½ miles) and the Loetschberg (9 miles). Other tunnels over five miles in length are the Ricken tunnel between Wattwil and Uznach (near the Lake of Zurich), the Moutier-Granges tunnel on the Bienne-Basel line, and the Hauenstein lower tunnel between Olten and Basel.

**The St. Gothard Tunnel**

The construction of the St. Gothard Tunnel was commenced in September 1872, driving proceeding from each end. Progress was made at the rate of 304 yards per month at each end when using rock drills. The chief difficulty in boring occurred where a variation in the condition of the strata to be traversed caused the drill to diverge sideways to softer rock and thus jam itself in the hole. The headings were joined on 29th February 1880, seven years and five months from the commencement of work. To show how greatly the adoption of improved machinery had speeded up the work it may be mentioned that the average daily advance of the two headings was six yards as compared with 2½ yards at the Mont Cenis Tunnel, to which reference will be made later. A considerable amount of water was encountered, whereas scarcely any water at all was met with in the Mont Cenis Tunnel.

The St. Gothard Tunnel was found to be 8½ yards shorter than had been calculated. The centre lines of the northern and southern sections of the tunnel, although prolonged for more than four miles from each extremity, differed in direction only by 13 in. at their junction, while the error in level was



Photo

**St. Gall Station**

[Swiss Federal Railways]

(Continued on page 348)

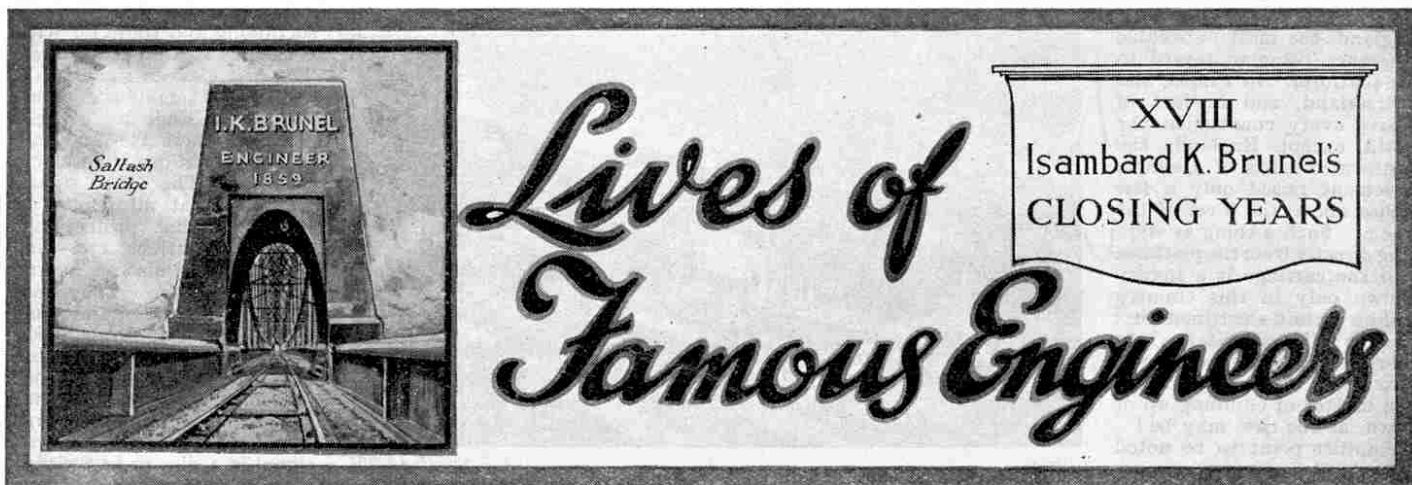

IN our account of the famous "Battle of the Gauges" we showed how Brunel's views were directly opposed to those of the two Stephensons. A similar state of affairs existed also in a remarkable railway project with which Brunel became associated and which proved to be an utter failure. This scheme was for the working of the South Devon Railway on the "Atmospheric System."

The idea of producing motion by means of atmospheric pressure is said to have originated with Papin, the French philosopher, more than two centuries ago. Little was done in the matter until 1810, however, when a Mr. Medhurst published a pamphlet with the object of proving the possibility of carrying goods and letters by this means. About fourteen years later a Mr. Vallence, of Brighton, took out a patent for a method of projecting passengers in special carriages through a large tube exhausted of its air, and in 1835 an American named Pinkus took up the same idea.

The scheme attracted a good deal of public attention and an association was formed—largely through the efforts of Dr. Lardner and Mr. Samuel Clegg—to carry it into effect. The sum of £18,000 was raised and a model apparatus was constructed and exhibited in London.

In 1840 Mr. Clegg and a Mr. Samuda patented a complete plan for an atmospheric system and tested its working on an unfinished section of the West London Railway. This experiment met with so much success that the directors of the Dublin and Kingstown Railway adopted the system for the line between Kingstown and Dalkey, and it was also adopted by the London and Croydon Railway.

The method employed on these railways was as follows. A cast iron tube, 15 in. in diameter, was laid down between the two rails of the track. At intervals of about three miles along the line were erected stationary engines driving powerful air pumps, by means of which air could be exhausted from the tube, thus creating a partial vacuum. Inside the tube at one end was placed a closely fitting piston connected to the carriages, and when the air was exhausted from the tube the pressure of the outer air forced this piston along the tube towards the air pumps, drawing the carriages with it.

#### Brunel Recommends Atmospheric System

About 1843 the directors of the Chester and Holyhead Railway requested Robert Stephenson to report on the advisability of

adopting the atmospheric system on that line. Stephenson based his report on experiments carried out on the Dalkey line. He stated that he was strongly averse to the adoption of the method on the grounds that, although it was capable of being developed into a practical working system, yet atmospheric traction must be much more costly than locomotive traction on lines with ordinary gradients, and more costly than rope traction on steep gradients.

About the same time Brunel became interested in the atmospheric system

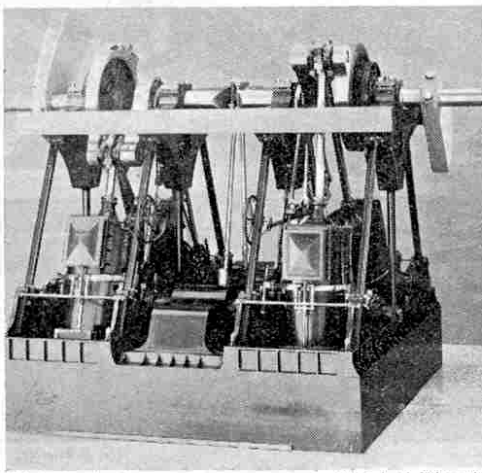

Photo courtesy] [Board of Education  
Model of the Paddle Engines of the "Great Eastern"

and after careful consideration he arrived at a directly opposite conclusion from that of Robert Stephenson. Brunel regarded the Dalkey experiment as being entirely satisfactory, and argued that a system of machinery which, even at the first attempt, had worked without interruption and constantly for many months, must be considered practically to be free from any mechanical objection.

In 1844 Brunel recommended the directors of the South Devon Railway to adopt the atmospheric system. The chief characteristic of this railway was that, while it traversed very heavy country, its principal changes of level were concentrated in four long and steep inclines. These inclines were intended to be operated by auxiliary power, and Brunel thought that the atmospheric system was the most suitable for this purpose. The directors of the railway resolved to act on Brunel's advice and work was commenced.

#### A Costly Failure

After many delays due to various causes a section of the line was completed and passenger trains commenced to run daily. To some extent the anticipated results were realised. The motion of the trains was smooth and agreeable and in one instance a speed of 68 miles an hour was recorded for a train of 28 tons. Serious difficulties quickly began to develop, however, and it was found that the cost of traction was nearly nine times as much as had been calculated, and was between two-and-a-half and three times what it would have been with locomotive traction. Brunel did his utmost to make the railway a success but without avail, and ultimately, on his recommendation, the directors abandoned the system.

The costly failure of the atmospheric system fully justified George Stephenson's prediction made after he had examined the model apparatus exhibited in London. "It won't do," he declared emphatically. "It is only the fixed engines and ropes over again in another form, and to tell you the truth I don't think this rope of wind will answer so well as the rope of wire did."

#### Dock and Pier Works

In addition to his work in connection with railways and steamships, Brunel found time to carry out various dock and pier schemes. His first important work of this kind was at Monkwearmouth, at the mouth of the river Wear opposite to Sunderland. For many years the question of making suitable docks to cope with the growing traffic had been under consideration and various designs had been proposed by different engineers, but no practical steps were taken.

In 1831 designs for suitable docks were submitted simultaneously by Brunel and another engineer. Brunel's docks were to have been on the north side of the river with an area of 25 acres. Neither of these designs was approved by Parliament, but soon afterwards a private company was formed with the object of constructing a dock on a plan designed by Brunel, but on a very much smaller scale than his original scheme, the area of this dock being only about six acres with a tidal basin of about one-and-a-half acres.

The town of Sunderland opposed the proposals of the company, but the latter succeeded in obtaining a royal charter for the construction of the dock, and subsequently an Act of Parliament giving them



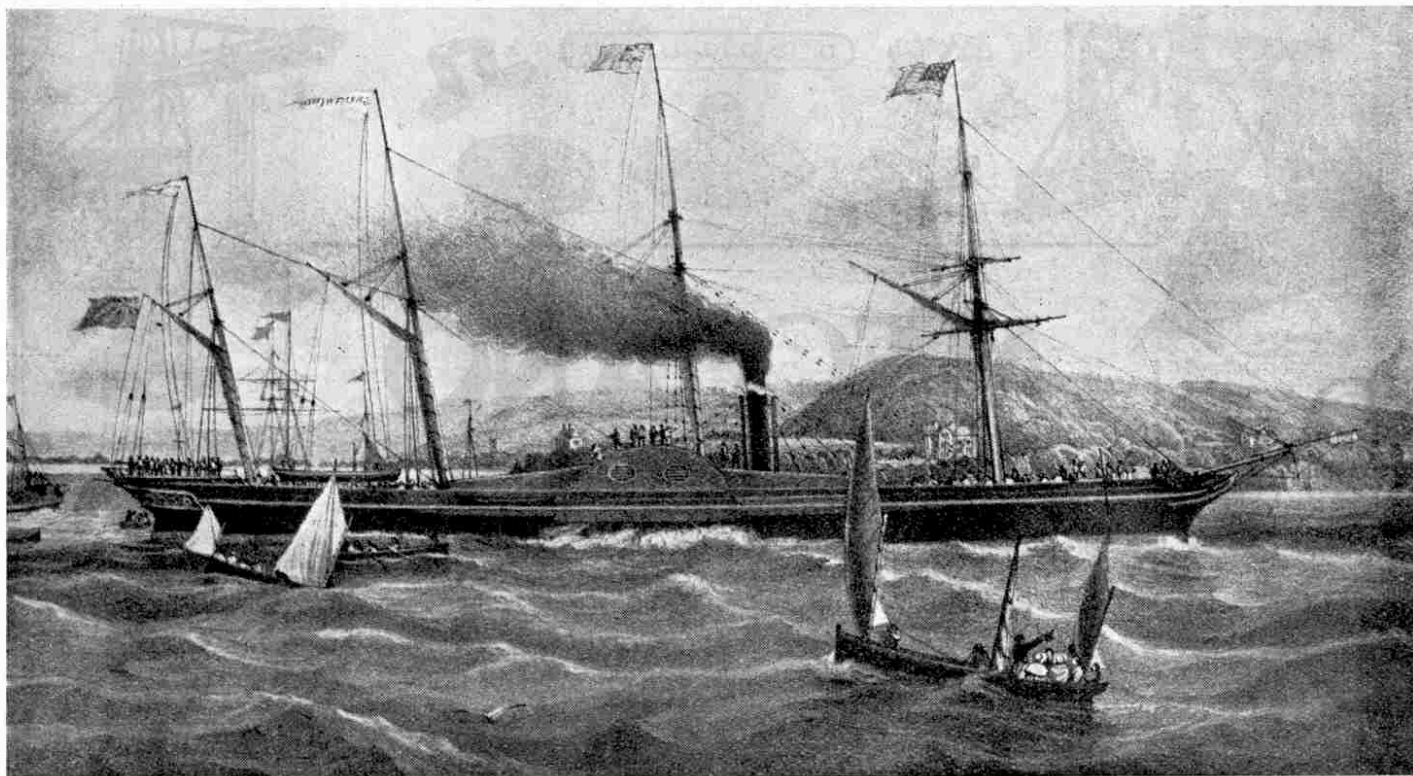

Photo courtesy]

[Board of Education

### The "Great Western"

power to make the entrance from the dock to the river. The dock was duly constructed and eventually became the property of the North Eastern Railway. An interesting feature about this dock is that the gates were built of timber, this being the only occasion on which Brunel did not use wrought iron.

#### Improvements at Bristol

In 1804 the portion of the river Avon flowing through the city of Bristol was enclosed, the water in it being thus retained at a constant level. This portion of the river, called the Floating Harbour or Float, was about two miles long and 100 yards broad. At its lower end it was connected to the river by a half-tide basin, called the Cumberland Basin, with two locks. As time went on, mud accumulated to such an extent in the Floating Harbour that the position became serious, and in 1832 the directors of the dock company consulted Brunel on the matter. He recommended various measures, some of which were acted upon, and some improvement was effected. One of his proposals for this purpose was to increase the amount of water passing through the Floating Harbour so as to prevent deposits settling.

Brunel also enlarged one of the locks between the Cumberland Basin and the river in order to permit of the passage of large vessels. The necessity for this had become strikingly evident when Brunel's ship the "Great Britain" was built, for in order to enable the ship to pass from the basin to the river a portion of the lock masonry had to be removed. The chief point of interest in Brunel's new lock lay in the fact that it was the first in which wrought iron gates were introduced, these gates being rendered buoyant by large air chambers formed in their lower portions.

Brunel was afterwards engaged on extensive dock and harbour work at

Plymouth, Briton Ferry near the mouth of the river Neath, and at Brentford on the Thames. He also gave a great deal of attention to the improvement of large guns and he designed a floating gun-carriage for the attack on Cronstadt in the Russian War of 1854. In the following year he designed and superintended the construction of hospital buildings at Renkioi on the Dardanelles.

#### Brunel's Career

Brunel's career affords a remarkable example of a combination of genius, energy and industry. When he was appointed engineer to a company he at once assumed the position of sole adviser to the company in everything relating to the construction and mechanical working of the undertaking concerned. He would not allow any one to be associated with him in the supreme control, and immediately he felt that the directors were losing any of their confidence in him he took immediate steps to resign his post at whatever sacrifice. On the other hand, so long as he felt that he had the whole-hearted support of the directors he devoted himself absolutely to their interests, never allowing considerations of convenience or even health to interfere with any work he felt would be to the benefit of the company. He was accustomed to place entire confidence in his assistants as long as he felt that they were carrying out their work in the proper manner, and he was always ready to shield his subordinates from interference by others. When anything did go wrong he was always eager to give the offender another chance.

#### General character

A good estimate of Brunel's general character may be obtained from the following extracts from a letter of one of his personal friends:—

"No one, I believe, ever saw him out of temper or heard him utter an ill-

natured word. He often said that spite and ill-nature were the most expensive luxuries in life; and his advice, then often sought, was given with that clearness and decision, and that absence of all prejudice, which characterised his opinions in after-life. All his friends of his own age were attached to him in no ordinary degree, and they watched every step in his career with pride and interest. In fact, he was a joyous, open-hearted, considerate friend, willing to contribute to the pleasure and enjoyment of those about him.

"His professional friends . . . and his private friends at all times well knew the genius, the intense energy, and indefatigable industry with which every principle and detail of his profession was mastered; and both knew and valued the high moral tone which pervaded every act of his life."

Although Brunel was in the forefront of almost all the great engineering controversies and contests of his time, he always maintained friendly relations with his fellow engineers. On this point the following short extract from one of Brunel's private journals is of interest. These words were written in 1846, at the height of the "Battle of the Gauges," in which Brunel and the Stephensons were opposed: "I am just returned from spending an evening with R. Stephenson. It is very delightful, in the midst of our incessant personal professional contests, carried to the extreme limit of fair opposition, to meet him on a perfectly friendly footing, and discuss engineering points."

#### Closing Days

There is no doubt that the gauge controversy and the fierce contest that followed it, together with the failure of the atmospheric system on the South Devon Railway, caused Brunel great anxiety and sorrow. The difficulties that occurred in the launch of the "Great

(Continued on page 361)

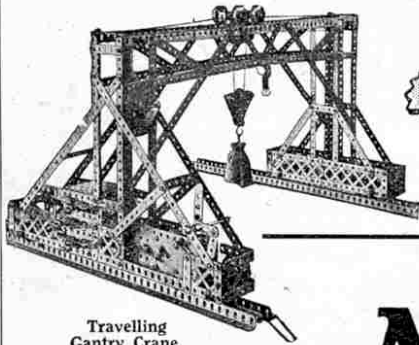

Travelling Gantry Crane

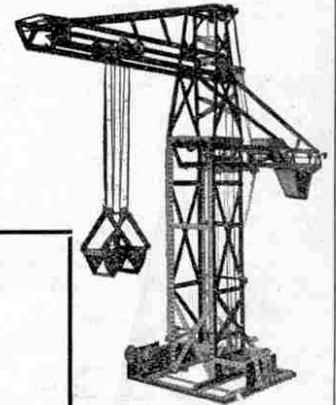

High-Speed Ship-Coaler

# MECCANO

ENGINEERING FOR BOYS

Meccano this year is heaps more fun than it has ever been before. Many new parts have been added recently, and this, of course, means new and better models.

There is no limit to the number of models any boy can build with a Meccano Outfit. The hundreds' shown in the Instruction Manuals are just suggestions and no boy ever stops when he has built them—he goes on building new models that he invents himself.

That's why Meccano is such splendid fun. The Crane you build to-day is a Tower to-morrow, a Motor Chassis the next day and so on. You can build a new model every day for years, if you wish! They will be real models, too, all sturdy and strong because they are built of steel. Meccano parts are exactly similar to the parts used by real engineers, only smaller. That's why Meccano Cranes lift and swing heavy loads, Meccano clocks keep perfect time, Meccano motor-cars run, and Meccano Looms weave real fabrics.

Meccano models are easy to build—you only require a spanner and screw-driver and these are provided in every Outfit.

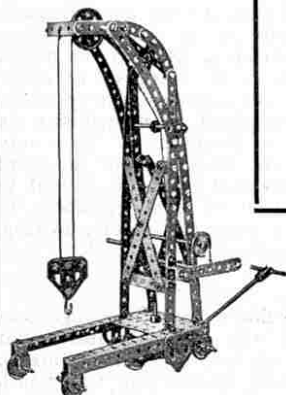
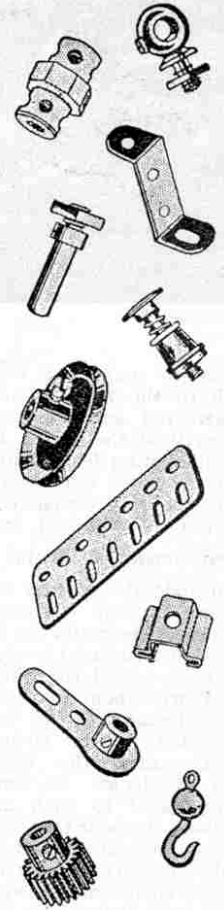
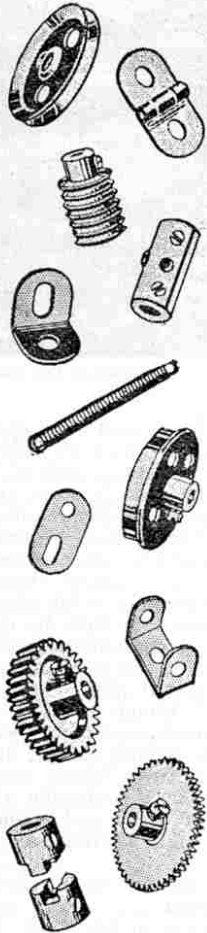

Platform Crane

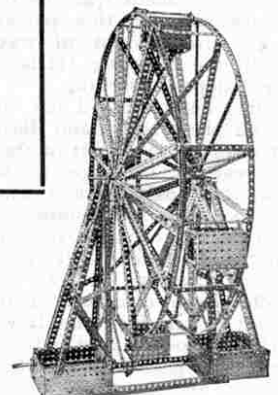

Big Wheel

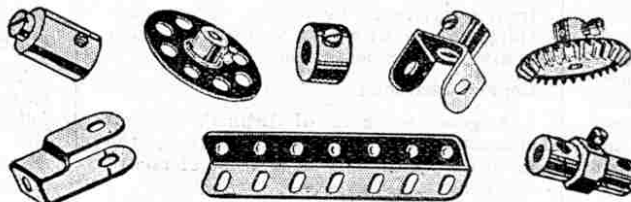

COMPLETE OUTFITS	
No. 00	3/6
No. 0	5/-
No. 1	8/6
No. 2	15/-
No. 3	22/6
No. 4	40/-
No. 5 (in well-made carton)	55/-
No. 5 (in superior oak cabinet with lock and key)	85/-
No. 6 (in well-made carton)	105/-
No. 6 (in superior oak cabinet with lock and key)	140/-
No. 7 (in superior oak cabinet with lock and key)	370/-

ACCESSORY OUTFITS	
No. 00a	1/6
No. 0a	4/-
No. 1a	7/6
No. 2a	8/6
No. 3a	18/6
No. 4a	15/-
No. 5a (in well-made carton)	50/-
No. 5a (in superior oak cabinet with lock and key)	80/-
No. 6a (in superior oak cabinet with lock and key)	210/-
Electrical Outfit	42/-

# A NEW MECCANO MODEL

## Model No. 627. Automatic Weighing Crane

**T**HIS is a model of a crane that, by means of a simple and ingenious contrivance, automatically registers the weight of the load which it is in the act of lifting.

The advantages of such an arrangement in actual practice are many and must be obvious. For example, a great deal of time is saved in loading goods wagons, ships, lorries, etc., where without a weighing crane much of the goods would have to be weighed on a separate machine, consequently incurring additional labour and increased expense in handling. Again, the crane operator can tell at any time from a glance at the load indicator, the extent of the stress to which the crane is being submitted and is thus able to keep within a certain safe margin of the capacity limit of the crane.

### Constructing the Model

- This is a simple and very interesting model to build, and our illustration shows very clearly most of the constructional details. The pedestal upon which it is mounted runs upon rails built up from Angle Girders, which, of course, may be extended to any desired length.

The wheel base consists of four Flanged Wheels (24), mounted in bearings (23) formed from 2½" Strips connected to the girders (20) by Angle Brackets. One of these Flanged Wheels is connected by gears to a hand-wheel (Fig. C), the operation of which imparts the traversing movement to the model along the rails. The upright columns (21) are connected at the top by 5½" Girders, and at the wheel base, where they are slightly splayed-out, by 9½" Girders. The construction of the strengthening struts is clearly shown.

The crane rotates on ball bearings (19) carried on an upper platform consisting of

two 5½" Flanged Plates, bolted between the upper 5½" Angle Girders.

The lower fixed race of the ball bearings is formed by bolting a Wheel Flange and 3" Pulley in the channel of the platform, and thus formed the Meccano Steel Balls are inserted. A further 3" Pulley Wheel is bolted to the under-side of the crane, secured in this through the 3" Axle Rod wheel passes freely Pulley fixed to the platform.

A 57-toothed Gear Wheel carried on this Rod is engaged by a Worm on the Crank Handle seen just in form in

below the platform. The large illustration shows the Load Indicator.

### The Load Indicator

The load is raised or lowered by the operation of the Crank Handle (1), upon which is wound a lifting cord (2, Fig. B), passing round a 1" Pulley (3) and over another 1" Pulley (4) at the jib head (Fig. D) to the loaded Hook (5).

This Pulley (4) is mounted in two Cranks (6) carried by means of a Coupling from the 3½" Rod (7) which is slideable in two Double Brackets (8).

A Sprocket Chain (9) is connected to a Collar mounted on the Rod (7) and passing round a 1½" Sprocket Wheel (10) and under the 1" Sprocket Wheel (11, Fig. B), is connected to a Spring (12) secured to a 3½" Rod (13).

Thus, when a load is being raised, the increased tension on the hoisting cord (2) tends to pull down the Pulley (4); the movement consequently imparted to the Chain (9) extends the Spring (12) and in doing so rotates the Sprocket Wheel (11).

The movement of this Sprocket Wheel is magnified to one three times as great

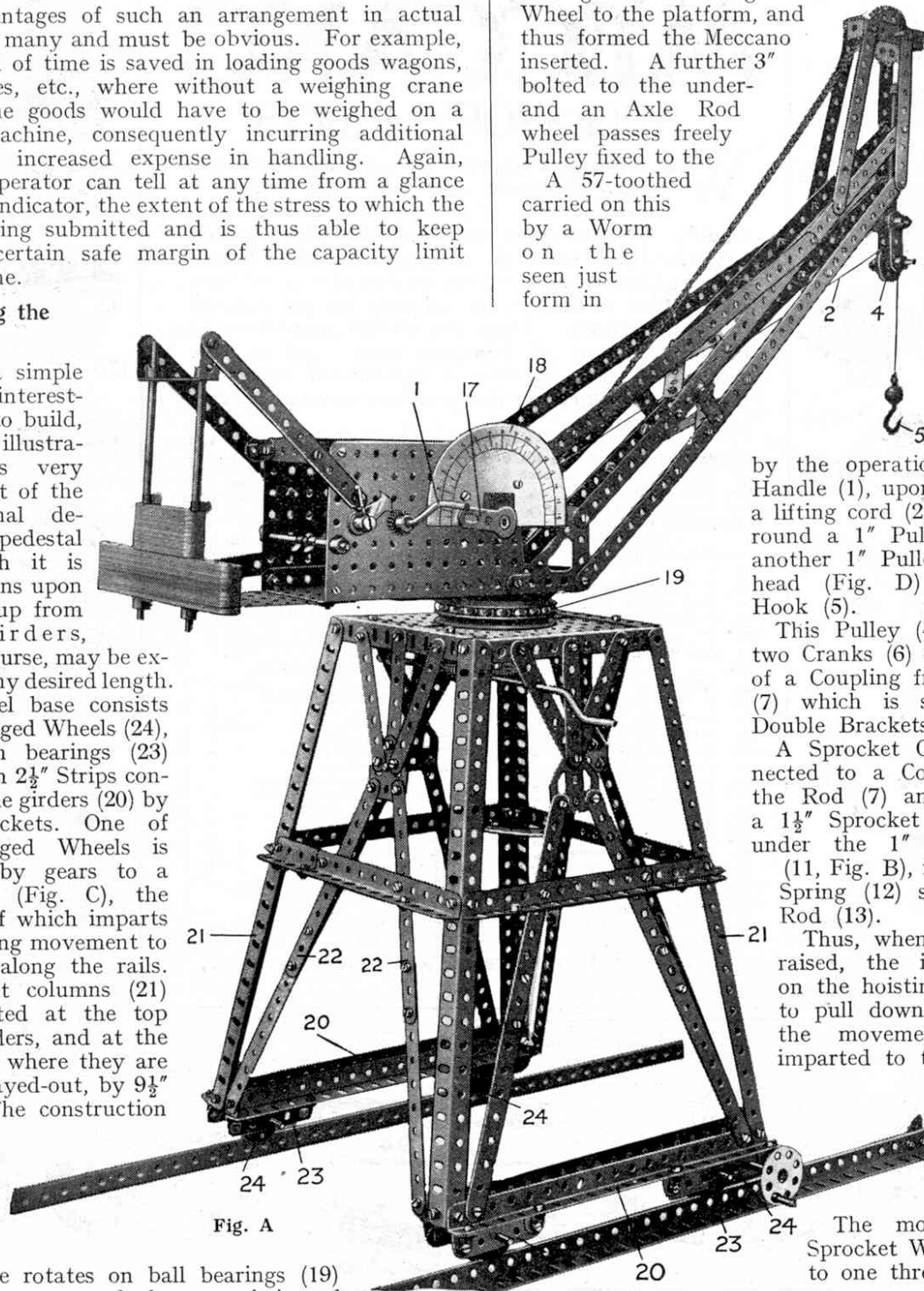
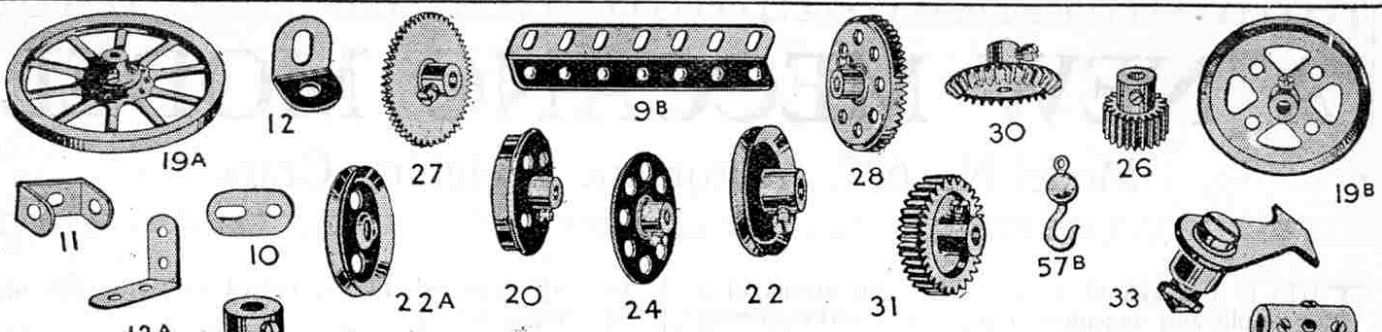

Fig. A

(Continued on page 331)



# MECCANO

## ACCESSORY PARTS

WE illustrate a selection of accessory parts that every Meccano boy will find useful in building the larger and more interesting models. Many of these parts have been only recently introduced, and although we know that they have a universal use (were it otherwise they would not have been added to the system) we may not yet know all their applications. There are endless possibilities in the employment of Meccano parts; indeed, we wonder if there is now a mechanical movement known to engineering that any boy cannot duplicate with Meccano.

	s. d.		s. d.
10. Flat Brackets ...	1/2 doz. 0 2	94. Sprocket Chain per length	0 6
11. Double Brackets ...	each 0 1	96. Sprocket Wheels, 1"	each 0 3
12a. Angle Brackets, 1" x 1"	0 1	101. Halds, for Looms ...	doz. 0 9
19a. Wheels, 3", with setscrew	0 8	108. Architraves ...	each 0 2
20. Flanged Wheels ...	0 6	109. Face Plates, 2 1/2" diam.	0 4
		113. Girder Frames ...	0 2
		114. Hinges ...	per pair 0 4
19b. 3" dia., with set screw	each 0 8	115. Threaded Pins ...	each 0 2
22. 1" " "	0 4	116. Fork Pieces ...	0 3
22a. 1" " without set screw	0 2	118. Hub Discs, 5 1/2" diam.	1 3
24. Bush Wheels ...	0 6	119. Channel Segments (8 to circle), 1 1/2" diam.	0 4
25. 1/2" Pinion Wheels ...	0 6	120. Buffers ...	0 2
26. 1/2" " "	0 4	120a. Spring Buffers ...	per pair 0 8
27. Gear Wheels, 50 teeth	0 9	123. Cone Pulleys ...	each 1 3
27a. 57	0 9	124. Revsd. Angle Brackets, 1"	0 10
28. 1 1/2" Contrate Wheels ...	0 9	125. Revsd. Angle Brackets, 1/2"	0 6
29. 1/2" " "	0 6	126. Trunnions ...	each 0 3
30. Bevel Gears ...	0 10	126a. Flat Trunnions ...	0 2
31. 1" Gear Wheels, 38 teeth	1 0	127. Simple Bell Cranks ...	0 3
32. Worm Wheels ...	0 6	128. Boss Bell Cranks ...	0 4
33. Pawls (complete) ...	0 4	129. Rack Segments, 3" diam.	0 6
43. Springs ...	0 2	130. Triple Throw Eccentrics ...	1 3
44. Cranked Bent Strips ...	0 1	131. Dredger Buckets ...	0 2
45. Double Bent Strips ...	0 1	132. Flywheels, 2 1/2" diam.	2 3
50. Eye Pieces ...	0 2	133. Corner Brackets ...	0 3
57b. Hooks (loaded) ...	0 5	136. Handrail Supports ...	0 3
59. Collars and Set Screws	0 2	137. Wheel Flanges ...	0 4
62. Cranks ...	0 3	138. Ship's Funnels ...	0 4
63. Couplings ...	0 6	139. Flanged Brackets, Right,	0 2
63a. Octagonal Couplings	0 8	139a. Left	0 2
63b. Strip Couplings ...	0 8	140. Universal Couplings	0 9
63c. Threaded Couplings ...	0 6	144. Dog Clutch ...	0 6
64. Threaded Bosses ...	0 2		

You may obtain Meccano Parts from your Dealer

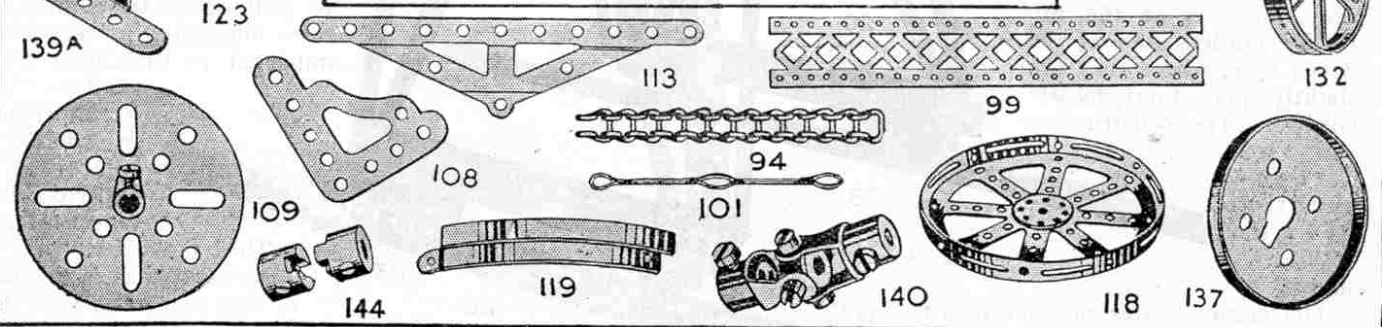
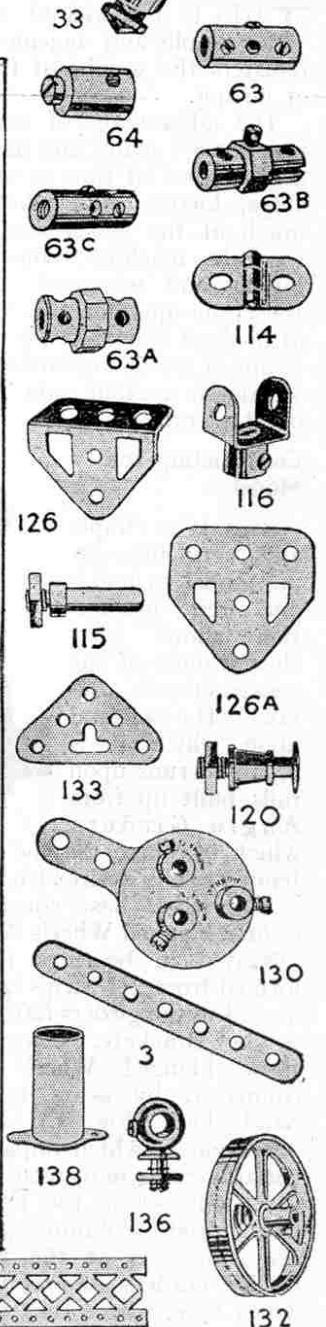

**Automatic Weighing Crane**—(continued from page 329)

by means of the 57-toothed Gear Wheel (14) and the 19-toothed Pinion (15). On the same Rod as the latter a Crank (17) is secured, which sweeps round the graduated dial (18), so registering the movements of the Chain (9).

**Marking the Dial**

The dial may be quite easily constructed by cutting out a semi-circular piece of cardboard and marking it in suitable degrees in order to indicate the weight of the load that is being lifted.

In the first place, with a view to ascertaining the correct position for the graduated divisions on the dial, a few experiments should be carried out with some known weights, and the respective positions of the pointer in regard to certain loads must be carefully recorded.

A friction brake is provided to control the hoisting cord. As may be seen from Fig. B, this brake consists of the usual lever and cord engaging a 1" Pulley mounted on the end of the Crank Handle (1).

It should be noted that the

Balls (19) in the Crane bearings have been only recently added to the Meccano system, and have not yet been included in the No. 6 Outfit, but they may be obtained separately. The model works well, of course, if the Jib is mounted on an ordinary swivel bearing, but its operation is greatly improved and better realism effected by the use of the ball bearings.

A counter-balance, consisting of a number of 5½" and 2½" Strips, is mounted at the rear of the jib, with the object of relieving the strain imposing upon the swivel-bearing.

*NEXT MONTH* :—  
**HAMMER-HEAD CRANE**

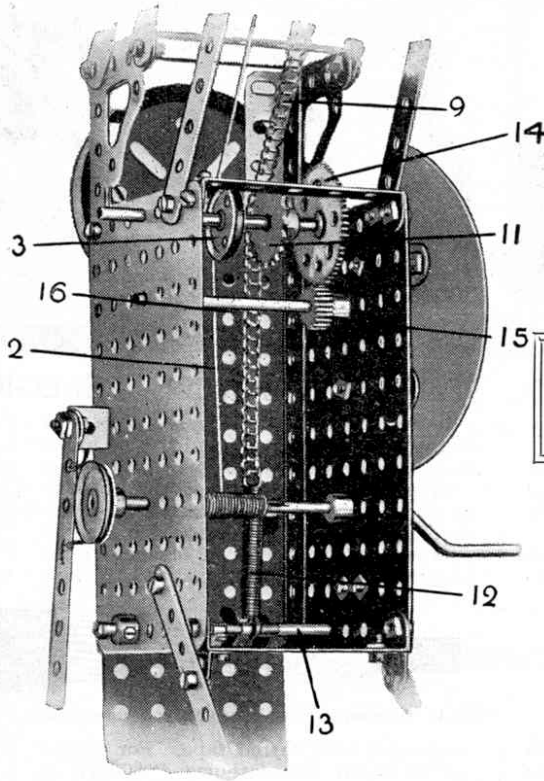

Fig. B

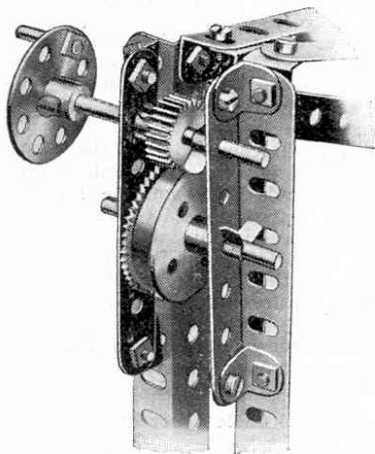

Fig. C

Parts required :								
8	of No.	1	2	of No.	19	4	of No.	48A
50	"	2	2	"	19B	3	"	52
2	"	2A	4	"	20	2	"	52A
10	"	3	1	"	22	1	"	57B
12	"	4	2	"	22A	15	"	59
36	"	5	1	"	24	3	"	62
2	"	6	1	"	25	2	"	63
2	"	6A	2	"	26	1	"	70
8	"	8	1	"	27	2	"	77
4	"	8A	2	"	27A	27"	"	94
12	"	9	1	"	32	1	"	95A
5	"	11	1	"	33	1	"	96
30	"	12	9	"	35	2	"	108
2	"	14	198	"	37	2	"	115
5	"	16	7	"	38	21	"	117
2	"	16A	1	"	40	3	"	125
4	"	17	1	"	43	4	"	126A
3	"	18A	1	"	46	1	"	137

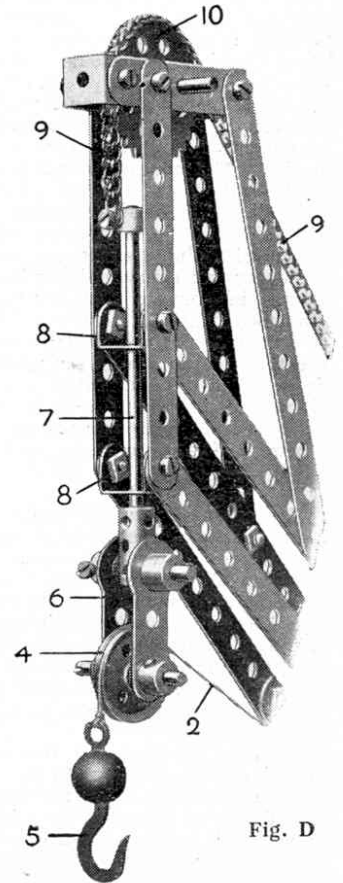

Fig. D

**How Cranes Help Trade**

Port Elizabeth, a seaport town some 400 miles east of Cape Town, is the second city in the colony and is situated on Algoa Bay, about 7 miles south of the mouth of the Zwartkop River. It is built along the base and up the rocky slopes of hills that rise to a height of 200 ft. above the bay.

The Port entirely owes its prosperity to its harbour and it has become the centre for the trade of the whole of the

interior of the country lying to the south of the great Zambesi. Previously there were no convenient landing places and so it was impossible for ships to load or unload. Some improvements in this respect were made in 1881 when the old pier was extended to a total length of 900 ft. and a second pier 800 ft. in length was constructed. Since that date even more extensive works have been carried out, and the harbour is now one of the finest in South Africa.

It is interesting to think of the indirect

part that Titan cranes have thus played in developing the trade of this wonderful colony—the cranes build the harbour, the harbour enables ships to load and unload, and the town becomes a leading port and the centre of trade for a wide and prosperous area. This is only one instance, of course, of how cranes help the engineer in his work, the execution of which would be quite impossible without them. No wonder, then, that cranes of all types are perhaps the most popular models among Meccano boys.



# Electricity

## XVII. THE SUBMARINE TELEGRAPH

THE story of submarine telegraphy affords a remarkable example of what may be accomplished by the efforts of a small band of enthusiastic workers fired with a determination to succeed in spite of all obstacles.

By the time that the land telegraph had become commercially practicable, engineers were already considering the possibility of linking continent to continent by means of submarine cables. The most important problem to be solved was that of insulating the cable. With overhead land cables insulation is effected without much difficulty by the use of porcelain insulators at every point where the line comes in contact with anything. With undersea cables, however, the entire length of the line must be insulated from electrical contact with the water in which it lies, because sea water is a good conductor of electricity and, in conjunction with the sea bed, is used as the return "wire" of the circuit.

### Early Experiments

The first person definitely known to have sent a current through an insulated wire under water was Colonel Pasley of the Royal Engineers at Chatham. In 1838 he was able to blow up the wreck of the "Royal George" at Spithead by means of an explosive fired electrically. In this instance the electrical impulse was transmitted along a wire insulated with tarred rope and covered with yarn soaked in pitch.

In 1840 Faraday and Werner Siemens, working independently, showed that gutta-percha appeared to be the most suitable substance for covering the wire core of a cable, as it was a very efficient insulator, absolutely waterproof, and also pliable and not liable to crack. Since that time scarcely any other material has been used as the primary insulator for undersea cables.

### Structure of a Cable

The conducting core of a cable consists of a number of strands of pure copper wire round a central wire of the same metal. The stranded form was suggested by Lord Kelvin in 1854 on the ground that its greater flexibility would make it less likely to damage the insulation when it was bent.

Around the central conductor are coated several thicknesses of gutta-percha and this coating is afterwards covered with

jute, yarn or hemp to form a soft bed for the sheath. This consists of galvanised iron or steel wires, each of which is first covered with a layer of tape and a compound consisting of gutta-percha, rosin and Stockholm tar. For the shore end of the cable the layer of hemp and the sheath are repeated and finally the whole

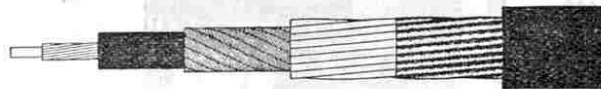

Fig. 1. Diagram showing Wrappings of Deep-sea Cable

is covered with tarred tape. For depths up to about 300 fathoms (1,800 ft.) it has been found necessary to further cover the whole with a layer of thin brass tape to protect the cable from a submarine boring animal known as "Teredo navalis," which regards gutta-percha as a great delicacy! Fig. 2 is a sectional drawing of the deep-sea type of cable, shown actual size.

### First Submarine Telegraph Company

On 16th June, 1845, two bric-a-brac shopkeepers, the brothers Jacob and John Watkins Brett, were sufficiently bold and confident to register the first submarine telegraph company in the world. Their object was to secure telegraphic communication between England and France by means of a cable laid across

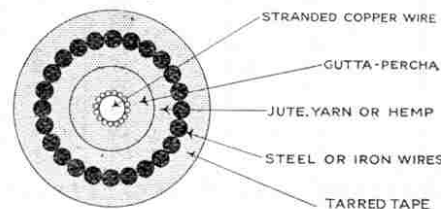

Fig. 2. Section of Deep-sea Cable

the Straits of Dover. They applied for Parliamentary permission for this undertaking, but they found that the then Prime Minister, Sir Robert Peel, had no confidence in their proposals. The only result of this application was to set in motion an apparently endless correspondence with various Government departments, and this lasted for some four years. The Bretts stuck to their point, however, and in 1849 they succeeded in obtaining the consent of both the English and French authorities for the laying of a cross-Channel cable.

The cable consisted of a single copper wire covered with a layer of gutta-percha half-an-inch thick. Leaden weights were attached to the cable at intervals of 100 yards, the fixing of each weight necessitating the stoppage of the cable-laying vessel, a very small tug curiously named "Goliath." The cable was safely laid and for one day it worked successfully. It then failed and all efforts to transmit further signals proved fruitless. Shortly afterwards a considerable length of the cable was brought up by a Boulogne fisherman in his trawl.

Short as was the life of this cable, the experiment proved that telegraphic communication between England and France was possible, but abuse and ridicule were showered on the enterprise, its opponents giving a very remarkable exhibition of ignorance. It is said that some people really believed that the cable was operated in the style of the old-fashioned house bell, and that signals were given by pulling the wire!

On 19th December, 1850, the French Government granted to Jacob Brett a concession and the Submarine Telegraph Company was formed. Great difficulty was experienced in obtaining the necessary money from the public, however, on account of the failure of the previous scheme. Matters were looking very hopeless, for only £300 had been subscribed, but the scheme was saved by T. R. Cramp-ton, a well-known railway engineer, who came forward with £15,000.

### Cross-Channel Cable Succeeds

A new cable was made, and at the suggestion of a Mr. Kuper, a colliery engineer, it was enclosed in a protective sheathing of iron wires. On 25th September 1851 the cable was laid from the South Foreland to about a mile from the opposite coast, and then, to the dismay of the engineers, it was found that the cable was too short to reach land. An extra length of cable was ordered immediately and was successfully spliced on to the first length and brought to shore. On 13th November, 1851, a public message was sent through this cable, this being the first public communication ever transmitted through a submarine line. The cable proved commercially successful and had a very long life.

The success of this cross-Channel cable led to the laying of a number of cables in various parts of Europe. In 1853, after

two unsuccessful attempts, a cable was laid between Port Patrick in Scotland and Donaghadee in Ireland under the supervision of Charles Tilston Bright, who was then, at the age of 20, engineer to the Magnetic Telegraph Company.

#### Atlantic Scheme Proposed

About this time the possibility of a cable across the Atlantic was arousing considerable discussion in telegraphic circles. Bright was convinced that telegraphic communication between Ireland and America was entirely practicable, and he used his utmost efforts to bring about the laying of an Atlantic cable. In America Cyrus West Field, a wealthy business man of exceptionally keen brain

and extraordinary physical energy, had become interested in the idea of an Atlantic cable, and through his efforts the New York, Newfoundland and London Telegraph Company was formed with a capital of one-and-a-half million dollars. After arranging all landing rights on the American side, Field and J. W. Brett, who had now become his chief engineer, came to London to discuss matters with Bright. The result of this meeting was the formation in this country in December 1856 of the Atlantic Telegraph Company, the capital for which was raised almost entirely in England by the public issue of 350 shares of £1,000 each.

The formation of this company produced a great storm of ridicule, mostly based upon ignorance. It is very strange, however, that so eminent a scientist as Professor Airy, then Astronomer Royal, should have stated seriously that it was a mathematical impossibility to submerge a cable safely to such depths, and that even if this could be done, messages could not be sent through such an enormous length of cable.

#### Making the Cable

The directors of the Atlantic Telegraph Company set to work immediately with the greatest energy. The proposed route for the cable was surveyed by taking soundings at intervals of about 100 miles and bringing up samples of the sea floor for examination. Meanwhile the construction of the cable was proceeded with, partly at Greenwich and partly at Birkenhead. The length of copper wire used in making the conductor was 20,500 miles, while the outer sheathing consisted of 367,500 miles of iron wire. The total length of wire used was sufficient to go round the whole earth 13 times! The cable was completed in June 1857 and was stowed away on two warships, the

"*Agamemnon*" and the "*Niagara*," lent by the British and the United States Governments respectively.

#### Two Attempts Fail

So far all had gone well, but serious troubles began with the laying of the cable. The shore end was landed in Valentia Bay and paying-out commenced.

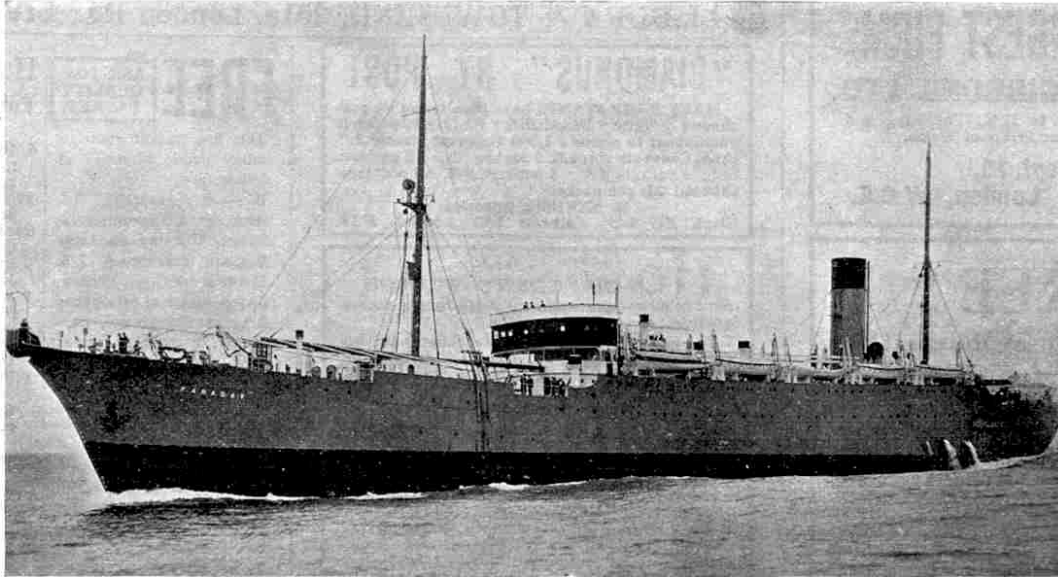

Photo courtesy]

The "*Faraday*," a modern cable-laying ship

#### Success—and Disaster

On 5th August 1858 the first telegraph message passed between England and America, consisting of an exchange of greetings between Queen Victoria and the President of the United States. Another important message transmitted prevented the sailing from Canada of two

British regiments that had been ordered to India during the Mutiny. In the meantime the Mutiny had been suppressed and these regiments were not required, and the despatch of the message saved a sum of about £50,000.

Every thing seemed to point to great prosperity on the part of the cable company, but after a short time the signals began to grow weaker and weaker, and at last, after some 700 messages had been transmitted, the cable failed entirely. This failure was a bitter disappointment to the engineers and electricians who had brought the cable into being and it was also a great blow to the general public.

The next point was to ascertain the cause of the failure, and after many consultations of experts it was unanimously agreed that the cable had been damaged by the use of too heavy currents. The setback received was so great that some years elapsed before another attempt could be made, but the idea was never abandoned and during this period the problems involved were studied minutely by experts. During this waiting period the energy of the American, Field, had full play. It is said that Field made no less than 64 crossings of the Atlantic on business connected with the cable, and considering that he suffered intensely from sea-sickness on every trip, we may form some idea of his pluck and endurance!

#### Another Attempt Abandoned

In 1865 preparations were made for another attempt. This time it was decided to use only one vessel for laying the cable, and the "*Great Eastern*" was chosen for the task. In July 1865 the "*Great Eastern*" set sail from Valentia, escorted by two British warships. After some 80 miles had been paid out, a fault occurred and, after drawing up some miles of the cable, it was found that a piece of iron wire had pierced the coating. The cable was repaired and paying-out continued successfully until over 700 miles had been laid, when another fault was reached and this also was found to be due to a piece of iron piercing through the covering of the cable. It seemed impossible that two such pieces of iron

(Continued on page 361)

[Messrs. Siemens Bros. & Co. Ltd.]

# Stamps for Sale

**ASK FOR**  
**THE BEST APPROVALS**  
 AND FINE FREE LISTS  
 FROM  
**THE BIGGEST FIRM**  
**STANLEY GIBBONS LTD.**  
 By Appointment to H.M. The King and  
 H.R.H. The Prince of Wales.  
 (Dept. 15.)  
**391, Strand, London, W.C.2.**

**FREE!**

**Grand Set of 7 Bolivia 1894**

1c. to 100c. complete, together with fine combined Perforation Gauge and Rule to all collectors sending 3d. (stamps) for my Grand "Epirus" Packet of 40 fine picked varieties including Epirus (Flag), Georgia, Iceland, Jamaica 1/- 1905 (Judicial), Russia (scarce 1 rbl.), N.S.W., Union of S.A., NZ. (Map and K.G. 2d.), Hungary, etc., etc., and asking to see my Bargain Approvals.

**WEMBLEY STAMP ON EVERY LETTER.**

**PHILIP J. DYKE**

**122, Gladstone Road, London, S.W. 19**

**IRISH FREE STATE**

We hold one of the most extensive stocks of these interesting issues and shall be pleased to receive enquiries.

3rd (fully illustrated) edition now on sale. "The Postage Stamps of the Irish Free State." A descriptive priced catalogue, 1/8 post free. P. W. WARE (Dept. M.), 69, Queen's Road, Clifton, Bristol.

**FREE! FREE!! FREE!!!**

Grand Packet Pictorials absolutely free to applicants for approvals.

Write to-day and you will be delighted. Beginners Album holds 2,000 stamps, 1/3 post free.

**L. C. JONES, 61, West Street, Bourne, Lincs.**

**CRESTS.** Splendid Collections.

Cricket Teams, British Regiments, British Ships, English Bishops, Famous Men, Lords, Dukes, etc., Colleges and Public Schools.  
 12, 9d.; 25, 1/4; 50, 2/6; 100, 4/9  
 Oxford and Cambridge, 12, 9d.; 25, 1/4; 72, 3/9  
 Scotch Clans, 12, 9d.; 25, 1/4; 40, 2/6  
 Saxon and English Kings, 12, 9d.; 24, 1/4  
 ALL DIFFERENT. Postage 1½d. extra.  
**Vivian Stewart, Dorincourt, Woodham Rise, Woking.**

**1,111 Try the Cheapest and Best 1,111**

Method of adding to your collection.

When you buy PACKETS you buy DUPLICATES. I will send you a book of 1,111 different stamps from which you may select any 100 for 3/-. BUY ONLY THOSE YOU REQUIRE.

**1,111** H. HARDY, 285, Archway Road, London, N.6. **1,111**

**£5 WORTH OF STAMPS FOR 5/-**  
 This Sale parcel contains over 750 different. Containing fine lot Mint Colonials:—From Antigua, Bahamas, British Honduras, Guiana, 1890 1c. on 2 Dols, Cayman, Dominica, Gi braltar, Gilbert and Ellice, Gold Coast, Jamaica, Kenya, Malta, Montserrat, Palestine, St. Kitts-Nevis, Trinidad, Turks and other used and unused stamps. Lot catalogued over £5 for 5/- post free. Abroad 6d. extra.  
**HILLIER, Stamp Mart, HORSMONDEN, KENT.**

**TWEEZERS, TITLES OF COUNTRIES, AND PEELABLE HINGES**

**COLLECTOR'S ACCESSORIES & THE "GREAT" (62) PACKET**

**FREE!!**

A splendid advertising offer containing: 62 all different stamps from Algeria, scarce old Holland, Duchy of Luxembourg, Ukraine Republic, Cuba, rare old G.B. German occupation of Belgium, 40 scarce all different unused interesting Scandinavia, pictorial Air-post Stamp, British Colonials, etc. Also a most useful pair of Nickel Tweezers, a fine tabulated list (Abyssinia-Victoria) of Countries, ready gummed, and a packet of finest Stamp Mounts. Request approvals and send Postcard only.

**LISBURN & TOWNSEND, 201a, London Rd., LIVERPOOL**

**"DIAMONDS" BY POST**

**MANY RARE STAMPS** have been found by purchasers of THE "DIAMOND" PACKET, which is guaranteed to contain 1,000 Unsorted Stamps 1/3 (from Convents abroad). 2 packets, 2/5; 3 packets, 3/8; 4 packets, 4/6; 5 packets, 5/6. All post free. (Abroad 3d. per packet).

**O. NERUSH, Importer**  
 /Dept. E), 2-22, Cathcart Hill, London, N.19.

**110 DIFFERENT STAMPS**

Sent to all genuine approval applicants enclosing postage.

Let me know whether you collect British Colonials, Foreign or General. Only fine copies sent. Selections of mixed stamps from 1d. upwards.

**ESCOTT C. BLAND,**  
 16, Mansfield Road, Parkstone, Dorset.

**FREE THE ELM PACKET 75 DIFFERENT**

Including splendid sets of 10 French Colonials, 10 Portuguese Colonials, also Persia (Lion), Deccan, China (ship), New South Wales (arms), Chili (Columbus), scarce Poland, Air Mails, many Colonials and scarce unused. Absolutely Free to genuine collectors requesting Approvals.

**J. BURTON,**  
 3, Elm Bank, Walton Breck Road, Liverpool.

**FREE** ASK FOR QUALITY PACKET.

This fine packet contains only good stamps as follows:—

Western Australia 1d. swan, set of 9 Scandinavia, Spain, Ukraine on large Russian catalogue 7/6. Hyderabad, Deccan, Greece pictorial catalogue 1/6. Austria horse, Germany 20 million marks, New Caledonia, Unused Portugal, New South Wales, Roumania; Set showing Miners, Blacksmiths, and Farmers. Sent absolutely free and post paid to all genuine collectors asking to see our approval books. Send a post card for the best packet ever given away.

**R. WILKINSON,**  
 Provincial Buildings, COLWYN BAY.

**Half Price Outfit**  
 For Stamp Collectors

1 Illustrated Album to hold 5,000 stamps ... 3 0  
 100 Different Foreign Stamps ... 6  
 50 Different British Colonials ... 9  
 1,000 English Stamp Mounts ... 6  
 1 Powerful Pocket Magnifier, with beautiful Shell Case 1 3  
 1 Metal Watermark Detector ... 4  
 1 Perforation Gauge 1  
 1 Ruled Duplicate Book to hold 500 stamps ... 6

Total usual price... 6 11

As an advertisement the entire outfit is offered for

**3/6** (Postage 6d. extra.)

**"1000" PACKET**

**A Wonderful Offer for**

The "1,000" Packet contains 500 excellently assorted stamps. A COMPLETE SHEET of 100 UNUSED (very useful for exchanging), a neat booklet (12 pages) for holding duplicates, 25 British Colonials, usually sold at 1/4d.—1d. each, including new and obsolete issues. 375 Magic "Strip" Mounts which are three times as quick as the old-fashioned single ones.

My Price List of stamp bargains: In addition FREE Sets will be sent to those who send names and addresses of stamp collecting friends.

**WATKINS (M. Dept.), GRANVILLE ROAD, BARNET, HERTS.**

**112 PACKET FREE**

containing Argentine cat. 3d., Dutch East Indies, Venezuela, China, Munich Exhibition, set German workmen, Crete revolution cat. 4d., Ceylon in new colour, Hyderabad (official), Brazil, Rhinisch Rühr (a scarce stamp), Roumania (portrait), long set of German numerals (fine large stamps), Ukraine, Poland, Large Pictorial German, the scarce 2.50 Mks., many war, revolution and armistice issues, over 60 unused, British Colonials, etc., etc., making a grand total of 112 different fine stamps. Sent free and post paid to all collectors requesting my famed approvals. Without approvals price is 1/-. Send a postcard now. Mention "Meccano."

**R. ALCOCK, 13a, Clarence St., CHELTENHAM.**

Breaking fine private collection of old Colonials. Selections on approval to advanced collectors, at

**Huge Discount of under 8d. in 1/- off Gibbons.**

Cat. Prices. References or deposit please. Collector, 23, Canning Road, East Croydon.

**OPPORTUNITY NOT TO BE MISSED**

Bargains for all. Giving up approval business. Whole stock to be cleared in packets of 250 unpicked. Price 1/- post order. Worth up to 10/-.

**SCOTT, 154, Wellesley Road, ILFORD.**

Would you like a

**GIBBONS 1925 CATALOGUE FREE P**

Pub. price 10/-.

Send for a Copy of our 12 PAGE PRICE LIST OF SETS AND PACKETS OF PORTUGAL AND COLONIES

ALL applicants will receive 9 MOZAMBIQUE CO. PICTORIALS FREE, but if 1½d. is enclosed for postage, and you ask to see our approval booklets, we shall send instead a

**FREE GIFT OF 15 MINT MOZAMBIQUE CO. PICTORIALS (Cat. S.G. 2/4).**

All purchasers of 1/- and upwards have the chance of winning the above catalogue.

**H. & G. H. JOPLING, 44, RISCA ROAD, NEWPORT (MON.)**

**The Latest Testimonial**

Client says, "Very pleased with everything."

Good value for money.

Are "You" getting good value?

Nyassa, 1901. Mint set 10 (animals) ... 1/3  
 Turkey, all diff. Mint 14 (pictorials) ... 1/6  
 150 all diff. Mint and used. Fine ... 8d.  
 500 all diff. Mint and used. Fine ... 1/9  
 Send for my famous 1d., 1/4d., 1d. approvals. Splendid value.

**W. H. TAYLOR, 26, Meadows Road, Sale, Chester.**

**BOUNTIFUL PACKET No. 5**

contains 2 triangular Austrian express; set 3 Kenya and Uganda; 4 Carinthia plebsicite; India, 1 rup.; Kedah; Japan, Coronation; Madagascar 25c. pictor.; large Malta (mint); Somaliland (Protect.); 15 Germany; 15 diff. Norway and 5 Malay (tiger). Price 8d. post free. Bargain No. 8.—50 diff. Sweden 6d., or 25 diff. 3d.

**W. E. WILLIAMSON,**  
 55, Nunhead Grove, London, S.E.15.

**FINEST AND CHEAPEST APPROVAL SERVICE IN THE TRADE**

Hundreds of stamps rarely met with in selections of cheap stamps are included in my approval books which are popular with collectors all over the world.

Give my service a trial and find out what real satisfaction means.

**THOS. G. RICHARDS (Dept. M.M.),**  
 5, Guilford Street, London, W.C.1.



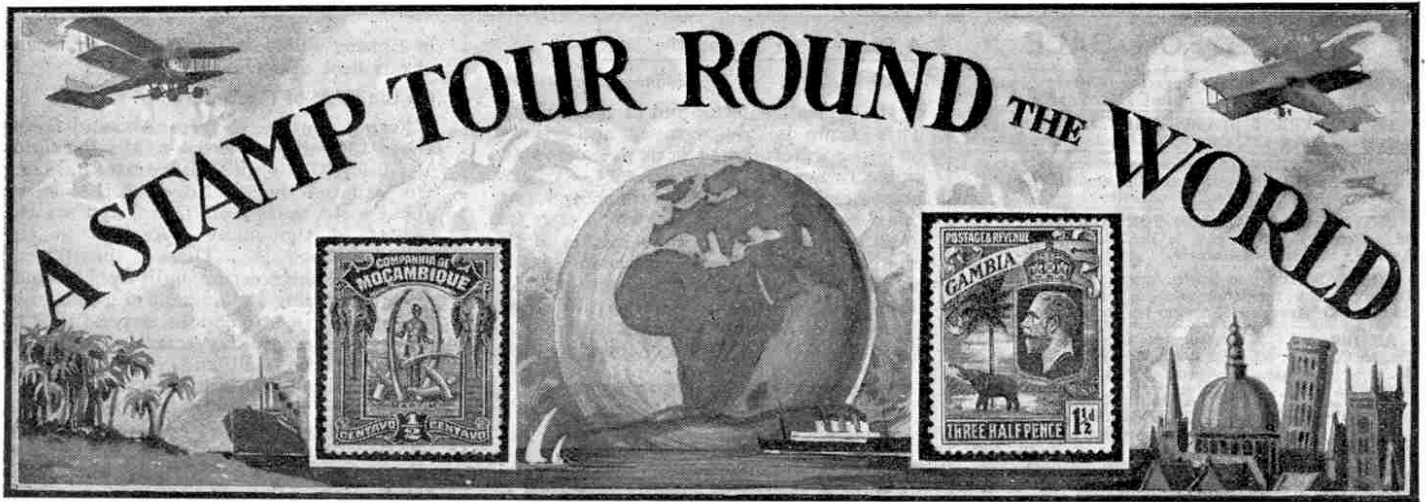

**XI. THE MEDITERRANEAN**

OUR ship having arrived safely at Casablanca, we make use of our aeroplanes and fly in a southerly direction over Morocco to Marrakesh, sometimes inaccurately called Morocco City.

This town lies on a large plain, and although in the past it has been a very important city (it was founded in 1062 by Yusef bin Tashfin), it is now in a state of decay. As an example of this it may be mentioned that in places the city wall, a structure from 25 to 30 ft. in height, has collapsed so much that pedestrians and often horsemen are able to pass through the gaps so produced.

A concrete of red earth and stone, known as *labiya*, is the popular building material in this town and the tower of the Kutubia Mosque is the only stone building in the city. This tower is pictured on the 35c. value of the 1917 and 1923 issues of French Morocco and is similar to the Borj el Hasan tower at Rabat, which we shall visit shortly. Both towers were built by the early Moors and, it is believed, both were designed by the same architect, a man named Jabir.

**Fez, Volubilis, and Rabat**

Flying now due north-east for about 230 miles, we come to Fez, the chief city, although not the capital of the country. It is beautifully situated in a valley on a small river and from a distance appears to be a most attractive place. Owing to its position on sloping ground, Fez has better drainage than most Moorish cities, but the streets are very narrow and dark while, owing to the general dampness, the town is very unhealthy.

The Karuein Mosque, one of the eighteen doors of which is shown on the 10c. is celebrated as being the largest mosque in Africa. The roof is supported by 366 pillars of stone and owing to the large area of the building appears to be very low. It is said that the mosque possesses 1,700 lights requiring three and a half hundredweight of oil for one filling!

Leaving Fez we now turn westwards and passing over the ruins of Volubilis, (2 to 10 frs. values), we come to Chella or Shella near Rabat on the Atlantic seaboard. At Shella are the ruins of Sala, a Roman colony, consisting of a mausoleum

of the Beni Marin dynasty (30c., illustrated here).

Continuing we arrive at Rabat, the capital of the country. The city was founded in 1184 by Yak'ub el Mansur and occupies a rocky plateau surrounded by massive but decaying walls. A prominent feature is the Borj el Hasan, already mentioned in connection with Marrakesh. It is depicted on the 1c. value of the series and consists of a square tower 145 ft. in height which has never been finished.

**Tunisia—A Roman Aqueduct**

From Rabat we fly south-westwards to Casablanca and regain our liner in which we set sail for the Straits of Gibraltar. After passing through this famous gateway of the Mediterranean we continue along the north coast of Africa until the seaport of Tunis is reached.

Outside this town is found the beautiful aqueduct erected by the Roman emperor Hadrian and extending from Zaghwan to Carthage. The ruins consist of hundreds of large stone arches, magnificent remains testifying to the skill of the Roman engineers. Tunisia is, in fact, as rich in Roman remains as Italy itself.

A view of Hadrian's aqueduct was shown in the higher values (35 to 75c., illustrated here) of the 1906 issue of Tunis and in the same issue (1 to 5c.) is shown a mosque at Kairouan. The name of this town is variously spelled Kairouan, Kerouan and Kairawan.

It is the "sacred" city of Tunis and is 80 miles south of the capital. The city contains some very fine examples of Saracenic art and although the streets have now been paved it remains very Oriental in appearance. This could hardly be otherwise for the houses are built round a central courtyard in the typical eastern fashion and only present blank walls to the streets.

**The Key of the Mediterranean**

Rejoining our ship we next pay a visit to Malta—that magnificent island in the centre of the Mediterranean that is so important to the welfare of the British Empire.

On 1st January 1901, Malta issued a stamp with a face value of 1d. (illustrated) showing a view

*(Continued on next page)*



## STAMPS FOR SALE

**FREE.** 50 Different Hungarian Postage, 1½d.—Howell, 20, Trilby Road, Forest Hill, London.

**100 DIFFERENT STAMPS FREE.** Send for ¼d. approvals.—Cox, 135, Cambridge Road, Seven Kings.

**STAMP APPROVALS.** Fine selections at lowest prices. About 1,000 foreign at ¼d., Colonials from ½d.—Wyk, Bolehill, Flixton, Manchester.

**BRITISH COLONIAL AND FOREIGN STAMPS** at 8d. in the 1/- discount.—J. McCallum, 56, Trefoil Avenue, Shawlands, Glasgow.

**FREE.** 30 Different South American, many mint. To applicants for approvals.—S. J. Huckle, 53, Birkenhead Avenue, Kingston-on-Thames.

**All Different.** 50 Portuguese Colonies, 6d.; 50 French Colonies, 8d.; 50 Roumania, 9d.; 50 Czecho, 6d.; 50 Bulgaria, 1/- Postage extra.—D. Hulse, Silverdale Road, Wolstanton.

**"THE PHILATELIC MAGAZINE,"** 46, Victoria St., London, S.W.1. Best stamp newspaper. Order from your newsagent. 3d. fortnightly, or send 4d. for specimen and bonus form worth 2/6. Album catalogue free.

**BRITISH COLONIALS,** 200 different, 3/9; 500, 15/-; 1000, 55/-; or a selection sent on approval at ¼d. each. Colonial Mixture including high values, 3/- per 1000.—Theobald, 54, Antill Road, London, N.15.

**Six Revolutionary Crete, 1905 (Cat. 1/8)** Free to "Big Discount" approval applicants.—H. Scott Johnson, C.P.A. Room, C. 49, Felden St., S.W.6.

**FREE!**

Fine collection of 100 different Foreign Stamps. Send 1½d. postage (Abroad 6d. P.O.) and ask to see Approvals.

W. A. WHITE, 18, Stourbridge Road, LYE, Worcestershire.

**100 DIFFERENT STAMPS** used and unused, including 25 British Colonials, 6d. post free. 100 Mounts and Perforation Gauge free with each packet.  
W. Gosling, 93, Wherstead Road, Ipswich.

**APPROVAL SHEETS Colonial and Foreign.** Take any 1/- worth for 6d. Take any 7/6 worth for 2/6  
" " 2/6 1/- " 20/- " 5/-  
Free packet including war and mint to first twenty applicants mentioning "Meccano Magazine."  
Miss M. Saunders, 16, Kent Road, East Molesey, Surrey.

**7/6 for 1/-**

Genuine collectors' duplicates in assorted parcels, all different, none damaged. Catalogue value £1 for 2/6, or Catalogue value 7/6 for 1/-, postage extra. Record value.

SMITH, 8, Fitzalan Road, Finchley, Church End.

## MINT BRITISH EMPIRE

WEMBLEY, 1925, 1d. and 1½d., adhesives; per pair 3d. Do. Per dozen pairs ... .. 2/9

NEWFOUNDLAND, 1923 Pictorials; 1c. green, 1d.; 2c. carmine, 2d.; 3c. brown, 2½d.; 4c. deep purple, 3d.; 5c. ultramarine, 4d.; 6c. slate, 5d.; 8c. bright purple 5½d.  
Postage extra. Ask for Price List.

ALEC. KRISTICH (N.R.P. 279),  
82, MARCHMONT STREET, LONDON, W.C.1.

## ANYTHING TO SELL?

**This Space** is set to 1 inch single column and costs 10/- per month.

This sum is the 32nd of £16, the price of a whole page advertisement. A half-inch advertisement costs only 5/- per month. At least 50,000 copies are distributed each month all over the world. You can therefore reach this exclusive public for less than 2½d. per thousand.

A WONDERFUL LITTLE HAND CAMERA.

## The "MONARCH"

Takes Perfect Photos, 2½in. x 1½in. Latest Improvements. Complete with Lens, Shutter and View Finder. All Accessories. Best quality Plate, Developing and Fixing Chemicals, Sensitized Paper, Printing Frame and full simple directions. Each Camera Guaranteed to take Good Photos. All purchasers delighted with splendid results. Send at once. Supply is limited. Price only 2/6 complete.  
F. Ratson (M), Copple House, Fazakerley, Liverpool.

## A Stamp Tour Round the World—

(Continued from page 335)

of the capital, Valetta, and of the harbour. This stamp is line-engraved and printed on paper watermarked with the customary single Crown CA, perforated 14. Valetta possesses massive fortifications and harbour works on account of which it is the great coaling and exchange station of the Mediterranean. The main island is 91 sq. miles in area and has Gozo (20 sq. miles) on the north-west with Comino (1 sq. mile) between. These with one or two uninhabited rocks complete the



group known under the general name of Malta. The nearest European coast is Sicily about 60 miles away, while Africa is 180 miles distant.

From Malta we continue eastward along the Mediterranean to Alexandria, the chief port of Egypt, situated 12 miles west of an ancient, but now dry, mouth of the river Nile.

### Egypt's Beautiful Views

Egypt issued a very fine series of stamps in January 1914, showing views of various famous spots in Egypt. The stamps were engraved and printed by De la Rue and Co. but later Messrs. Harrison and Sons took over the printing. The paper has a chalky surface, watermark star and crescent, perforated 14.

No change was made in the stamps when the British Protectorate was declared on 18th December 1914 and Hussein Kamil became sultan.

In October 1915, the 3 m. value of the 1914 issue was surcharged "2 Milliemmes" in English and Arabic. Sultan Ahmed Fuad (now King Fuad I.) succeeded Hussein Kamil in October 1919, and two years later the series was reprinted by Harrison and Sons on paper with a new watermark known as triple crescent and star. An interesting point about these stamps is that the numeral indicating the value is in what we should term English figures in the left-hand corners of the stamps and in Arabic figures in the right-hand corners, while the words "Egypt Postage" also appear in Arabic.

### Ras Et-Tin Palace, Alexandria

The 3 milliemmes value shows the huge Ras et-Tin palace, built by Mehemet Ali, overlooking the harbour in the rue Ras et-Tin in the Arab quarter of Alexandria. This is on the cape of the same name and is westward of the central portion of the city. The words Ras et-Tin mean "Cape of Figs." For over a thousand years Alexandria was the capital of Egypt, although this position is now held by Cairo, with which Alexandria is connected by rail, telegraph, and telephone. The streets in the central portion of the port are paved with blocks of lava and lit at night by electricity.

At Alexandria we leave our liner for the last time, for the remainder of our tour in Africa and the whole of our tour

in Europe will be accomplished by means of our fleet of aeroplanes.

### On the Edge of the Desert

Flying south-east from Alexandria for about 130 miles we arrive at the Pyramids of Giza (1914, 4 mls., illustrated). They are situated on the edge of the desert about eight miles from Cairo, and are the largest of the many pyramids in the neighbourhood. These magnificent triumphs of engineering, built by thousands of slaves during the ancient civilisation of Egypt with a stupendous expenditure of energy, remain to-day scarcely altered to testify to the skill and perseverance of the early inhabitants of this land.

Here also is the celebrated Great Sphinx of Giza, often referred to merely as The Sphinx (1914, 5 mls., illustrated), and also all stamps from 1867 to 1906. It is 189 ft. in length and is carved from the solid rock into the shape of a lion's body with a human head. It faces eastward looking over the Nile valley and from the inscriptions in the shrine between its paws it appears to have represented the sun-god Harmachis. It is believed that this sphinx was sculptured to guard the entrance to the Nile valley.

**NEXT MONTH:—**

**EGYPT, ERITREA and DJIBOUTI**

## Stamps that Cannot be Bought Singly

The United States have issued two new stamps and these have the distinction that no one can buy one! They are to be used for certain classes of mail and are of ½ cent. and 1½ cent. value. The former bears a head of Nathan Hale, the American captain, who was hanged as a spy by the British at New York in 1776. Of this remarkable man it is remembered that his last words were "I only regret that I have but one life to lose for my country!" The 1½c. stamp bears the same portrait of President Harding that appeared on the Harding memorial stamp.

Curiously enough it is impossible to buy single specimens of either of these stamps, as there are no half-cent. coins in circulation.

## Air-Mail Stamps

One of the latest "fashions" in stamp collecting is the collection of air-mail stamps, and already some of the early stamps have reached high prices. For instance, when the late Mr. Harry Hawker attempted to win the £10,000 prize for flying across the Atlantic in May 1919, he carried a special bag of letters, which was afterwards rescued. They are marketed now at from £40 to £60 each. When, a month later, the late Sir John Alcock and Sir A. W. Brown made the first direct Transatlantic aeroplane flight, winning the "Daily Mail" £10,000 prize, they carried 3 lbs. mail. The envelopes are now worth £35 apiece.

The Martinsyde machine which had to abandon the Atlantic flight carried a bag containing about 60 letters. A few of these were overprinted "Aerial Atlantic Mail—J.A.R." the initials of the Postmaster-General of Newfoundland. They are priced at £100 each to-day.

In August 1910 at Blackpool, Mr. C. Grahame-White carried a mail-bag by aeroplane for a distance of 7 miles. The envelopes are now priced at £12.

# The Conquest of the Air

## V. A Light Aeroplane with Interchangeable Wings



Courtesy]

The Parnall "Pixie III."

[Messrs. G. Parnall & Co.

It has been stated that before many years have passed light aeroplanes will be as common as bicycles, and that business men will fly to work, alighting on specially-made roofs in the cities, and close to their offices. Whether this state of things will come to pass remains to be seen. One thing is certain, however, and this is that if their fathers fly to the office, Meccano boys will insist on flying to school! Going to school in such circumstances will indeed be a pleasure, especially if boys are allowed to spend their holidays in the air!

The day of the light aeroplane is certainly quickly approaching, and it only remains for some industrial genius to come along and give us 'planes at a price within the reach of all.

In our March and April issues we gave particulars of an interesting little machine and this month we are able to describe yet another light aeroplane that will be the envy of every reader whose ambition is to possess his own 'plane. This aeroplane (illustrated above) is the Parnall "Pixie," the total weight of which is only 530 lbs., or less than 5 cwts., including fuel and oil.

### Top Speed 105 miles per hour

The Parnall "Pixie" was really designed as a single seater light aeroplane for the sportsman who already has some flying experience, although he may not be a fully expert pilot. Fitted with large-surface wings, the "Pixie" is capable of a top speed of approximately 90 m.p.h., a speed quite high enough for those who have not had a great deal of experience.

Normally the "Pixie" can land at just over 30 m.p.h. but when small wings are fitted and the machine is flown by an experienced pilot, the landing speed is increased to about 45 m.p.h. with a top speed of 105 m.p.h.

The following are the principal details of the "Pixie III." Overall length: 20 ft. 6 in. Height (as monoplane): 6 ft. Height (as biplane): 7 ft. 9 in. Span of top plane: 26 ft. Span of bottom plane: 32 ft. 6 in. Tail plane span: 8 ft. 4 in. Track: 4 ft. 4 in. Main plane area (monoplane): 138 sq. ft. Main plane area (biplane): 242 sq. ft. Diameter of propeller: 4 ft. 9 in. Air speed: 75 m.p.h.

The "Pixie" is of the semi-cantilever type, the wings being attached to the bottom rails of the fuselage, and braced to the top rails by adjustable streamline struts. This arrangement possesses many advantages including the fact that the pilot sits above the wings and has an excellent view all round and for landing.

### Position of Seats

This position for the wings also allows the crew to be practically on the centre of gravity of the machine. Since in an aeroplane of this class the crew's weight represents more than one third of the total, the reduction of the moment of inertia due to this position is important and results in improved response to the controls.

Then again, the low position of the wings gives a cushioning effect when alighting, thus reducing the landing speed. As the tail plane is situated well above the main planes, it is kept out of the main plane "burbles" at slow speeds.

It is interesting to note that both wing incidence and dihedral angle may be set with accuracy by means of the adjustable bracing struts, thus avoiding the difficulty in the accurate adjustment of the wings, a disadvantage always found with the true cantilever types.

The fuselage is built of spruce longerons and diagonal struts and fixed together with three-ply gussets. It is completely covered at the forward end with a metal plate, which acts as a shield between the engine and the cockpit. Metal fittings are used at all points of attachment of the engine mounting, wings, tail unit, and under carriage.

The roomy cockpits are equipped with air speed indicator, cross level, aneroid, engine revolution indicator, petrol level gauge, oil sight feed and engine switch.

### Wing Construction

The main planes are of timber construction and—as in the case of the fuselage—steel fittings are used at all points of attachment.

The wing design is unusual. From the fuselage to a little distance beyond the attachment of the bracing struts the chord is constant and the spars parallel. Beyond this point the front spar carries on straight and the back spar rakes forward sharply to meet the front spar at the wing tip. The aileron spar is hinged to the outer portion of the rear spar, thus giving the aileron a raked forward appearance.

This arrangement renders the wings extremely stiff in torsion which makes for effective aileron control. In this connection it may be mentioned that bad

(Continued on page 348)

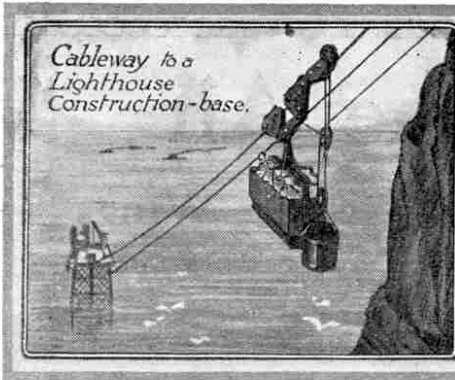

# Engineering News

## of the Month

### New Bridge at Berwick

An improvement to the Great North Road will be effected by a new bridge to be built at Berwick, between the old bridge and the Royal Border Bridge. It is claimed that this will have the longest spans of ferro-concrete in this country, 235 ft., 248 ft. and 167 ft.

### World's Largest Warship

The United States aeroplane carrier "Lexington" when completed will be the largest warship in the world, eclipsing in size even the British battle cruiser, H.M.S. "Hood." The "Lexington" will be 900 ft. in length and 106 ft. in width and will be driven by quadruple screws at a speed of 35 knots. Power from four turbo-generators, capable of developing 180,000 h.p., will supply eight electric motors, two driving each propeller.

The vessel will be very fully equipped with a repair shop for wings and fuselage, an optical repair shop, instrument shop, pigeon loft, and complete photographic laboratory, and will carry a crew of 178 officers and 1,498 men.

In appearance the "Lexington" will be something of a freak, all her deck structures being built on the port side to allow for a clear space of two acres for the landing and launching of aeroplanes. The hull is so constructed that it is almost shell and bomb proof, while the ship's great speed should enable it to keep well clear of any enemy vessels.

### The Flettner Rotor Ship

In connection with our article on the Flettner Rotor Ship, which appeared in the January issue, it is interesting to note that the German Naval Administration has placed an order with the Weser Concern for the first large Rotor cargo ship, the vessel to be of 3,000 tons.

The order has been placed, in conjunction with the Hamburg firm of Rbt. M. Sloman Junr., and in agreement with the German Shipowners Union, in order that a good practical test may be made of the Flettner design. Regulations for the navigation of rotor ships have now been issued by the German Authorities.

### Oil Cracking Plant for Baku

For the conversion of mazout into benzine an oil cracking plant is to be erected at Baku by Messrs. Vickers, in conjunction with the Soviet Government. This is believed to be the first time that such a plant has been erected there.

### The Niagara Cantilever Bridge

Now that the new steel arch bridge over Niagara is in service, the demolition of

the old cantilever bridge is going on rapidly. The bridge is being cut away by means of acetylene torches, and this is far the biggest job of its kind ever undertaken in this manner. The work was commenced over midstream, and timber falseworks have been erected on each side of the river to take the weight of the cantilever arms as the bridge is removed.

The demolition of the bridge, which has been in continual operation since 1883, will occupy the whole of the summer.

### A Birmingham Canal

A deputation, consisting of representatives from Birmingham, Manchester, Liverpool, Stoke-on-Trent, Smethwick, Wolverhampton, West Bromwich and Walsall, recently waited on the Minister of Transport with a view to obtaining financial assistance from the Government for the construction of a canal from Birmingham to the sea. The proposed canal, which would accommodate barges up to 100 tons, would cost altogether over £6,500,000, and would be 82 miles in length, its course being through Wolverhampton to the Potteries and on to the Weaver navigation. It is estimated that by means of the new canal the whole journey would take only 34½ hours.

### New Reservoir

A new reservoir, capable of holding nearly 300 million gallons of water, is at present being constructed near Huddersfield by Messrs. Lehane, Mackenzie & Shand on behalf of the Batley Corporation. The reservoir, together with the pipe lines to Batley, will cost altogether £500,000 and will take 5 years to complete. Work has now been in progress for some time and the blasting of the main trench was commenced when the first charge was fired at the official opening ceremony in May last.

### World's Largest Power Plant for New York

The New York Edison Company announce that they are to construct in Manhattan a new generating station costing \$50,000,000, with a capacity of 700,000 kilowatts, or 1,000,000 h.p. The new station will be capable of lighting 3,000,000 houses of six rooms each, and its capacity covers the lighting of the whole of the State of New York, excluding New York City. The station will be erected on the water front of Manhattan, so that it will be able to unload coal direct from steamers at the rate of 500 tons an hour.

800,000 gallons of water per minute will be pumped into the station from the East River, being returned almost immediately, so that every 24 hours the amount of water pumped in and out of the station will be 1,152,000,000 gallons!

The power will be generated by means of nine gigantic turbo-generators, each capable of developing 60,000 kilowatts, together with additional machinery bringing the total capacity of the station to 700,000 kilowatts. The General Electric Company of Schenectady have already been awarded a contract for the first two of these generators, each of which will weigh 1,182,500 pounds, and we hope to describe these in a future issue of the "M.M."

### Huge Circular Saws

A timber company in Everett, Washington, has recently installed the two largest circular saws in the world, each being 110 inches in diameter, containing 190 teeth, and weighing 675 lbs. With these saws 48 in. logs can be cut at the rate of 112 cuts per hour.

### Mammoth Floating Dock's Voyage

The ex-German floating dock, measuring upwards of 700 ft., which is to be used for docking the battleships of the Mediterranean Fleet, has left Sheerness on its long tow to Malta.

Six naval tugs are towing the great structure, and the dock is escorted by the destroyer Thanet.

### Repairing Giant Lock Gates

The task of removing and repairing six giant lock gates weighing 160 tons each has just been successfully completed by the L.M.S. Railway at Grangemouth Docks, Firth of Forth.

These great gates, which control the entrance to the docks from the sea, were removed, repaired, and replaced without interfering with the ordinary working of the docks. For the initial task of removal the power of the sea itself was used by the engineers.

The gates, which are hollow, and are filled with water to give weight to them, were emptied and made watertight. The rising tide then floated them off their bearings. They were taken in tow and placed in a graving dock.

After being cleaned and repaired they were towed back to the docks, placed over the bearings at high tide, and with the ebb they sank slowly into position.

### Waterloo Bridge Bomb

A short time ago, during excavation work at the base of one of the new iron piers of Waterloo Bridge, an unexploded German aerial bomb was retrieved from the mud. The bomb had obviously been dropped from an enemy aeroplane during the war. Had it fallen a matter of twenty feet further westward there would have been no controversy over the propriety and necessity of rebuilding Waterloo Bridge!