

Meccano Trick Cyclist

FEATURED here is an amusing model which shows that even a few Meccano Electricit parts can greatly increase the scope of standard parts. By using only a Commutator, a 1½ in. radius Wiper Arm and an Insulating Fishplate, it has been possible to animate this cyclist, so that he 'pedals' his way round the central stand. The platform on the top of this stand, incidentally, is for the battery powering the Emebo Motor, which actually drives the model. Construction is as follows:

The Cycle

The frame consists of two similarly constructed sides each built up from two 3½ in. Narrow Strips 1 and 2, two 3 in. Narrow Strips 3 and a 2½ in. Narrow Strip 4. Strips 1 and 2 are connected at the front by a Fishplate 5, at the same time bolting two ½ in. by ½ in. Double Brackets 6 and 7 in place. These Double Brackets, along with Double Brackets 8, 9 and 10, hold each side of the frame together. A 1½ in. Rod is journalled in the frame, as shown, being held in place by a 1 in. fixed Pulley 11 at one side and a Collar 12 at the other.

Another 1½ in. Rod is mounted in Double Brackets 6 and 7 and is held in position by a Short Coupling 13 above Bracket 6 and by a Large Fork Piece 14 beneath Bracket 7. Both the Coupling and the Fork Piece are spaced from the Brackets by three Washers. A further 1½ in. Rod, carrying a Coupling 15 at

Close-up view of the cycle and cyclist

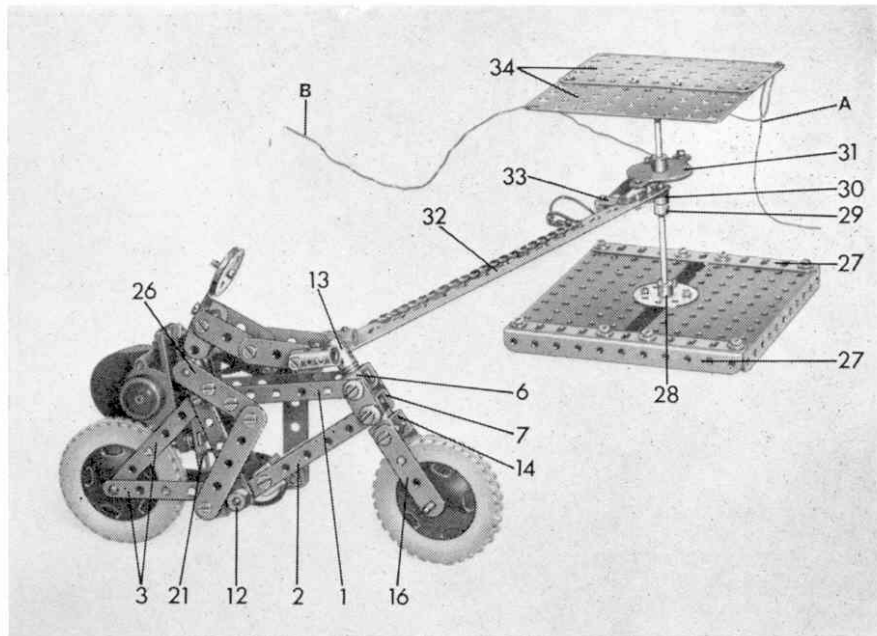
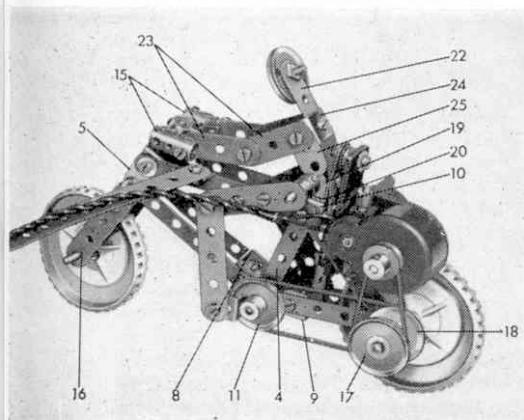

This intriguing model in Meccano is self-propelled

each end, is secured in the upper transverse bore of the Short Coupling, while the lugs of the Fork Piece are extended by 2 in. Strips 16, to complete the front fork.

Both wheels are represented by 2½ in. Road Wheels, the front mounted on a 1½ in. Rod, and the rear on a 2 in. Rod which also carries two 1 in. Pulleys with boss 17 and 18.

The Cyclist

A Double Bracket 19 and an Angle Bracket 20 are bolted to Double Bracket 10, then a 3½ in. Strip 21 and a 2½ in. Strip 22, curved slightly, are fixed to the other lug of Angle Bracket 20. At its other end, Strip 21 is fixed to Double Bracket 9. Each arm is formed from two 1½ in. Strips 23, attached to Strip 22 by another Double Bracket 24, at the same time bolting Fishplates 25 in position. Strips 23 are connected to Couplings 15 by ½ in. Bolts.

Journalled in the lugs of Double Bracket 19 is a 2 in. Rod, held in place by a Crank at the right-hand side and a Collar and a Crank at the left-hand side. Both Cranks are extended by 2 in. Strips 26 to each of which a 2½ in. Strip is lock-nutted. The other ends of Strips 26 are lock-nutted to Angle Brackets, one of which is fixed to the boss of Pulley 11 and the other to Collar 12. A 1 in. loose Pulley on a ½ in. Bolt represents the head.

The Motor

An Emebo Motor is fixed by ½ in. Bolts to Strip 21, but is spaced from it by three Washers on the shank of each Bolt. A ½ in. Pulley on the Motor shaft is connected to Pulley 17 by a 2½ in. Driving Band and Pulley 18 is connected to Pulley 11 by a 6 in. Driving Band.

Two 5½ in. by 2½ in Flanged Plates are

connected by two 5½ in. Angle Girders 27 and an 8-hole Bush Wheel 28. A 5½ in. Rod carrying a Collar 29, a Crank 30 and a Commutator 31, is fixed tightly in the boss of the Bush Wheel. The Collar and Commutator are fixed on the Rod, but the Crank is free to turn.

Crank 30 is extended by a 12½ in. Strip 32, to which an Insulating Fishplate 33 is bolted. A 2½ in. Wiper Arm is secured through the other hole of this Fishplate and is arranged so that it is in constant contact with the Commutator. Strip 32 is fixed to left-hand Strip 1 by an Angle Bracket. Two 4½ in. by 2½ in. Flat Plates 34 are bolted to another 8-hole Bush Wheel which is fixed to the top of the 5½ in. Rod.

Wiring Connections

A lead A is taken from one terminal of the battery and is earthed by connecting it to one of the bolts fixing Plates 34 to the Bush Wheel. The other battery lead B is taken from the Bolt holding the Wiper Arm, is run along Strip 32, and is connected to one terminal of the Motor. A lead from the other terminal of the Motor is earthed by connecting it to a bolt held in Strip 32.

Parts required

1 of No. 1;	1 of No. 22a;	1 of No. 116;
1 of No. 3;	2 of No. 24;	1 of No. 186;
3 of No. 5;	61 of No. 37a;	1 of No. 188a;
4 of No. 6;	50 of No. 37b;	2 of No. 187;
4 of No. 6a;	33 of No. 38;	2 of No. 235;
2 of No. 9;	2 of No. 52;	4 of No. 235a;
4 of No. 10;	2 of No. 53a;	4 of No. 235b;
7 of No. 11;	3 of No. 59;	1 of No. 513;
4 of No. 12;	3 of No. 62;	1 of No. 532;
1 of No. 15;	2 of No. 63;	1 of No. 551;
2 of No. 17;	1 of No. 63d;	1 of No. 558;
4 of No. 18a;	3 of No. 111a;	1 Emebo
3 of No. 22;	3 of No. 111c;	Electric Motor

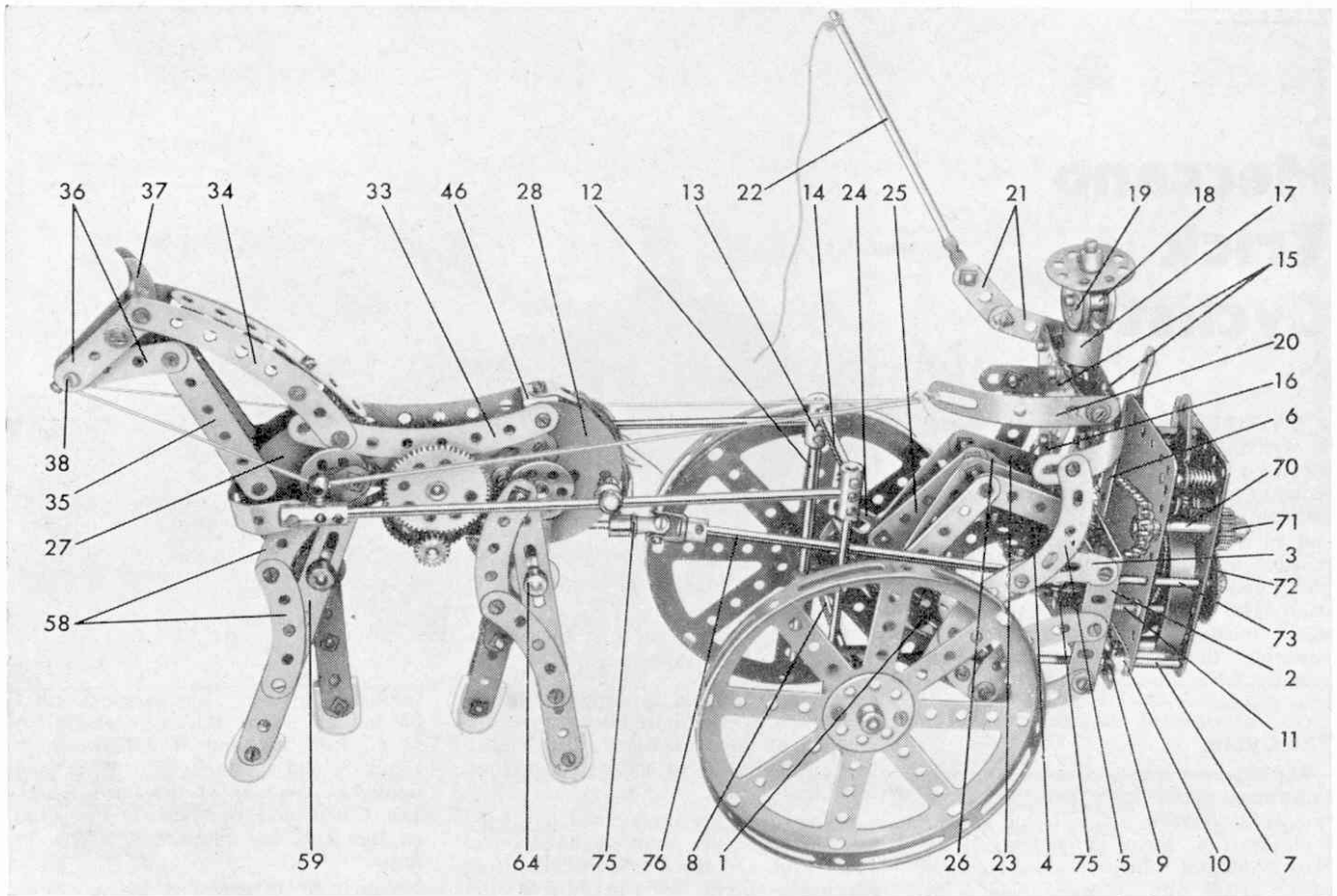

The unique model of a Horse and Chariot. For full building instructions read this article.

BUILD A HORSE AND CHARIOT

NOVEL animated Meccano models have always been a particular favourite of mine. The Horse and Chariot I describe here is, I think, unique, in that the Chariot is actually pulled along by the walking movement of the horse. A No. 1 Clockwork Motor fixed to the rear of the Chariot provides the power for the model.

Everybody claims that you cannot put the cart before the horse but, for building instruction purposes, I have done just that. If you study the photographs you will see that two legs have been removed in two of them. This has been done in order to simplify description.

The Chariot

Two 3½ in. by 2½ in. Flanged Plates 1 and 2 are connected at each side by two Curved Strips and a 3 in. Stepped Curved Strip 3, this last extended by a Fishplate. A seat is provided by a compound 3½ in. by 1½ in. flexible plate 4, built up from two 2½ in. by 1½ in. Flexible Plates fixed to Curved Strips 3 by Angle Brackets, at the same time bolting 2½ in. Curved Strips 5 in place. Strips 5 are joined by two Formed Slotted Strips

which are connected to Plate 2 by a 4½ in. Strip 6.

Mounted in Plate 2, as shown, are two 5½ in. Rods 7, each carrying a Coupling at its forward end and a Collar behind the Plate. A 6½ in. Rod 8 is journalled in the transverse bores of these Couplings, being free to turn, but held in position by Collars. A 3½ in. Strip 9 is slipped on to Rods 7 and is held against the Collars by a Crank 10 on each Rod. Also mounted on the Rods is a No. 1 Clockwork Motor which is bolted to Cranks 10. In addition, the Motor is fixed direct to Plate 2 by two 1½ in. Bolts 11.

Fixed in the forward transverse bore of each Coupling is a 4½ in. Rod 12 which also carries a Coupling 13 at its upper end. Couplings 13 are connected by a 3 in. Rod 14. Hub Discs, bolted to 8-hole Bush Wheels secured on Rod 8, represent the Chariot wheels.

The Charioteer

Two 2½ in. Triangular Plates 15 are bolted, one each, to two Flat Trunnions 16, then both constructions are connected by five Double Brackets, one placed at

each corner, and the last in the centre of the upper sides of the Triangular Plates. Three Washers are placed on a 1½ in. Bolt, which is then pushed upwards through the last-mentioned Double Bracket. A Chimney Adaptor 17 is added, and the Bolt is screwed into one side of the boss of a 1 in. Pulley 18. A 1 in. loose Pulley 19 is fixed to Pulley 18 by a ¾ in. Bolt, a Washer being used as a spacer, and a hat is supplied by an 8-hole Bush Wheel held by another ¾ in. Bolt screwed into the other side of the boss of Pulley 18, a Collar separating the Bush Wheel from the boss.

The left arm is represented by a Formed Slotted Strip 20, while the right arm is built up from two 1½ in. Strips 21, extended by a Rod and Strip Connector. Fixed in this is a 5 in. Rod 22, to which a short length of Cord is tied, to serve as a whip.

Each leg is formed from a 2 in. Strip 23, bolted to the respective Double Bracket, to which a 2½ in. Strip is attached by a ¾ in. Bolt. A Fishplate 24 and another 2½ in. Strip 25 are bolted to the other end of the first 2½ in. Strip. Fastened to Strip 25 by two Nuts on the

already-mentioned $\frac{3}{8}$ in. Bolt is a $1\frac{1}{2}$ in. Strip 26.

The horse

Both sides of the body, neck and head, are similarly built. Two Semi-Circular Plates 27 and 28, each extended by a Flat Trunnion 29 and 30 (this last extended by a $2\frac{1}{2}$ in. Strip 31), are connected by a $2\frac{1}{2}$ in. Strip 32 and a 4 in. Stepped Curved Strip 33, the latter extended by another 4 in. Stepped Curved Strip 34. A 3 in. Strip 35 is bolted to Plate 27 and this is connected by two 2 in. Strips 36 to Curved Strip 34, at the same time fixing a Pawl without boss 37 in position. The sides and head are connected by a $\frac{1}{2}$ in. Bolt 38, on which a Collar is mounted, a $\frac{3}{4}$ in. Bolt on which a Threaded Boss 39 is mounted, and a Double Bracket 40, to which a $3\frac{1}{2}$ in. Strip is bolted.

A Flat Trunnion 41 is fixed direct to left-hand Strip 32, while another Flat Trunnion 42 is secured to right-hand Strip 32, but is spaced from it by a Collar on each $\frac{1}{2}$ in. Bolt. The two sides are now connected by four Double Brackets 43, 44, 45 and 46.

Journalled in Semi-Circular Plates 28 is a $1\frac{1}{2}$ in. Rod that carries a 1 in. Bush Wheel 47 (Elektrikit Part No. 518) at each end, and a 57-teeth Gear Wheel 48 in the middle. This Gear is in constant mesh with another 57-teeth Gear 49 on another $1\frac{1}{2}$ in. Rod, held in place by a further 57-teeth Gear 50. Gear 50, in turn, is in mesh with a $\frac{1}{2}$ in. Pinion 51 on a 2 in. Rod, mounted in the apex holes of Trunnions 41 and 42. Also fitted on this rod are five Washers, a Coupling 52 and a $1\frac{1}{2}$ in. Contrate Wheel 53. In mesh with Contrate 53 is a $\frac{1}{2}$ in. Pinion 54 on a 3 in. Rod 55 which is free to turn in Coupling 52 and Double Bracket 45, being held in position by a Collar 55. Two Washers separate Pinion 54 and Coupling 52.

Gear Wheel 49 is in constant mesh with yet another 57-teeth Gear 56 on a $1\frac{1}{2}$ in. Rod, journalled in Semi-Circular Plates 27. Another two 1 in. Bush Wheels 57 hold this Rod in place.

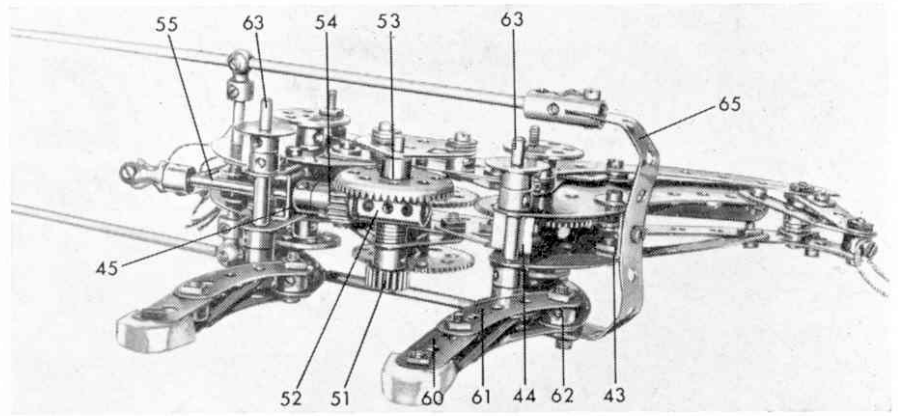

An underneath view of the Horse.

Four legs are built up, the two left being identical, as also are the two right. Two $2\frac{1}{2}$ in. Curved Strips 58 are joined together as shown, and bolted to a $5\frac{1}{2}$ in. slotted Perforated Strip 59. A 2 in. slotted Perforated Strip 60 and another $2\frac{1}{2}$ in. Curved Strip 61 are, in turn, joined together and connected to slotted Strip 59 and Curved Strip 58, but are spaced from them by a Collar 62 on the shank of each $\frac{1}{2}$ in. Bolt. A piece of rubber eraser, shaped as shown, is bolted between the ends of slotted Strips 59 and 60. All four legs are similarly built except that both the left and right pairs have slotted Strips 60 and Curved Strips 61 on the inside.

Two $2\frac{1}{2}$ in. Rods 63 are mounted, one in Strips 31 and the other in the bottom holes of Semi-Circular Plates 27, both being held by two Collars at each end. A $\frac{3}{8}$ in. Washer is placed on the ends of both Rods and the respective legs fitted by means of the upper slotted holes in slotted Strips 59, Collars 64 holding them in place. At their tops, the legs are lock-nutted to 1 in. Bush Wheels 47 and 57, but care must be taken with the 'timing'. The bolt fixing the left foreleg to the Bush Wheel must be at 3 o'clock when that holding the left hind leg is at 9 o'clock. At the same time, the bolt holding the right foreleg must also be

at 3 o'clock when that holding the right hind leg is at 9 o'clock. A tail is provided by several short lengths of Cord tied to an Obtuse Angle Bracket bolted to Double Bracket 46.

The Harness

A $4\frac{1}{2}$ in. Strip 65, carrying a Strip Coupling at each end, is bent to shape and bolted to Double Bracket 43. Screwed into the centre transverse tapped bores of the Strip Couplings is a Handrail Support 66. Lengths of Cord are then taken from a bolt in the horse's 'nose' through the Handrail Supports and tied to Formed Slotted Strip 20, to serve as reins. A 2 in. Rod, held by two Collars 67, and carrying a Handrail Coupling 68, at each end, is mounted in Plates 28. The horse is now harnessed to the chariot by two 8 in. Rods 69, secured in the Slotted Coupling, Handrail Couplings 68 and Couplings 13.

All that now remains to be done is the gearing down of the Motor and the coupling-up of the drive to the horse. A $\frac{3}{4}$ in. Sprocket Wheel on the Motor output shaft is connected by Chain to a 1 in. Sprocket Wheel on a 2 in. Rod 70, journalled in the Motor side plates and held by a $\frac{3}{4}$ in. Pinion 71. This Pinion is in mesh with a 50-teeth Gear 72 on a 2 in. Rod 73 that protrudes through Flanged Plate 2. Rods 73 and 55 are connected, via two Universal Couplings 74 and 75, by a $5\frac{1}{2}$ in. Rod 76.

The Horse viewed from above.

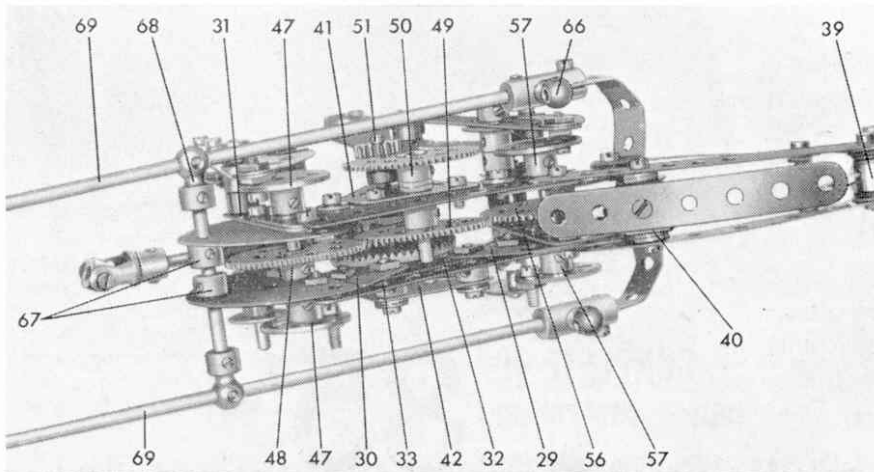

Spanner

Parts required	1 of No. 25	1 of No. 96
2 of No. 2a	2 of No. 26	1 of No. 96a
2 of No. 3	1 of No. 27	5 of No. 111
2 of No. 4	4 of No. 27a	11 of No. 111a
8 of No. 5	1 of No. 28	12 of No. 111c
6 of No. 6	119 of No. 37a	3 of No. 111d
4 of No. 6a	82 of No. 37b	2 of No. 118
4 of No. 10	51 of No. 38	8 of No. 126a
10 of No. 11	4 of No. 38d	2 of No. 136
4 of No. 12	1 of No. 40	2 of No. 136a
1 of No. 12c	2 of No. 53	2 of No. 140
2 of No. 13a	4 of No. 55	2 of No. 147c
1 of No. 14	4 of No. 55a	1 of No. 164
3 of No. 14a	31 of No. 59	2 of No. 188
1 of No. 15	2 of No. 62	1 of No. 212
2 of No. 15a	5 of No. 63	4 of No. 214
3 of No. 16a	2 of No. 63b	3 of No. 215
2 of No. 16b	2 of No. 72	4 of No. 518
3 of No. 17	2 of No. 89a	1 No. 1 Clock-work Motor
3 of No. 18a	4 of No. 89b	
1 of No. 22	12 of No. 90	4 pieces rubber eraser
1 of No. 22a	6 of No. 90a	
3 of No. 24	1 of No. 94	