

New Meccano Model

Mechanical Shovel

OUR new model this month is a realistic mechanical shovel fitted with creeper tracks and powered by a Meccano E20R type Electric Motor. All the movements of the model are power driven, and steering is carried out by disengaging the drive to the appropriate track.

Construction should begin with the undercarriage, which is assembled by bolting a $5\frac{1}{2}$ " Flat Girder 1 (Fig. 2) to each flange of a $3\frac{1}{2}$ " x $2\frac{1}{4}$ " Flanged Plate 2. Other $5\frac{1}{2}$ " Flat Girders are then attached to $1\frac{1}{2}$ " x $\frac{1}{2}$ " Double Angle Strips bolted to the Flat Girders 1, and the driving Sprockets are fixed on 2" Rods mounted in the Flat Girders. The Sprockets are linked by Sprocket Chain, which represents the tracks, and a $\frac{1}{4}$ " Sprocket on one of the 2" Rods on each side is also connected by Chain to a similar Sprocket on a 2" Rod 3. Each of the Rods 3 carries a $\frac{1}{2}$ " Pinion 4, and these can be meshed with $\frac{1}{2}$ " Pinions 5 fixed on a sliding Rod mounted in the Flat Girders 1. Pinions 5 are positioned so that when the Rod is in its central position each of them is in mesh with one of the Pinions 4, but by sliding the Rod one set of Pinions is disengaged.

Movement of the sliding Rod is controlled by a Pivot Bolt fixed in a Coupling 6. This Bolt engages between a Collar and one of the Pinions 5, and the Coupling is carried on a Rod mounted in a $2\frac{1}{2}$ " x $\frac{1}{2}$ " Double Angle Strip attached to Flanged Plate 2. A Motor Tyre fixed on a 1" Pulley maintains a light friction on the Rod, and a Crank forms the operating handle.

One of the Pinions 5 is in constant mesh with a

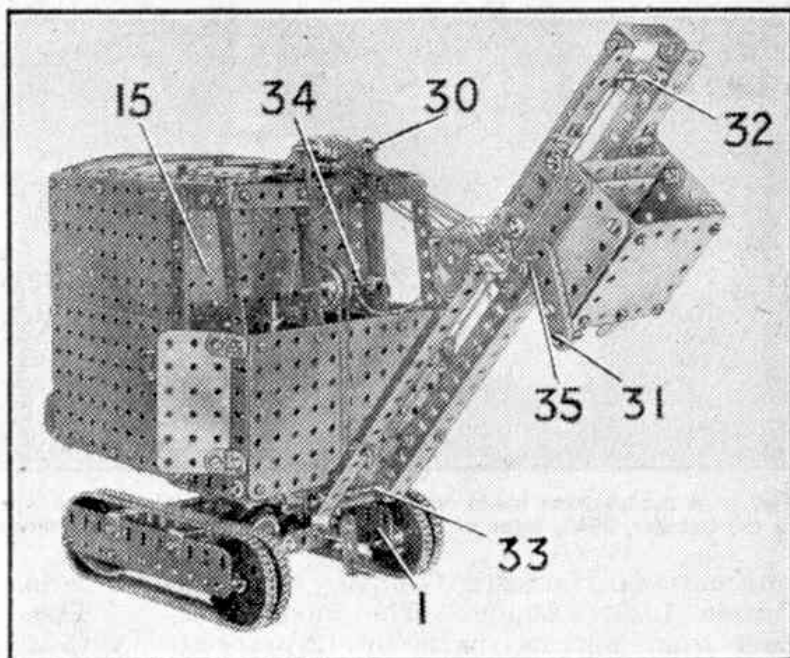

Fig. 1. This fine working model of a mechanical shovel has creeper tracks and is driven by an Electric Motor.

$\frac{1}{2}$ " Pinion 7, fixed on a Rod that carries also a $\frac{1}{2}$ " Pinion 8. Pinion 8 can be meshed with a $\frac{1}{4}$ " Contrate 9, but by sliding the Rod the two gears are disengaged, the disengagement being controlled by a Pivot Bolt fixed in a Coupling 10. The Pivot Bolt engages between a Collar and the $\frac{1}{4}$ " Pinion 8, and the Coupling is fixed on a Rod mounted in a $2\frac{1}{2}$ " x $\frac{1}{2}$ " Double Angle Strip bolted to the Flanged Plate 2. The control arrangements for this Rod are similar to those for the Rod carrying Coupling 6.

The Toothed Disc of a Ball Race is fixed to four Double Brackets bolted to the Flanged Plate 2. The Flanged Disc of the Ball Race is attached to the cab, and the Contrate 9 is fixed on a 5" Rod passed through the centre of the complete Ball Race. A Collar is used to hold the Rod in position.

The base of the superstructure is formed from two $7\frac{1}{2}$ " Angle Girders joined by $5\frac{1}{2}$ " Angle Girders 11, 12 and 13, and by a $5\frac{1}{2}$ " Curved Strip 14. The Flanged Disc of the Ball Race is attached to Angle Girders 12, and the E20R Electric Motor is bolted to one of these and also to Angle Girder 13. The sides of the cab are assembled from Flat Plates bolted to a framework of Strips and Angle Girders. A partition 15 consisting of a $5\frac{1}{2}$ " x $2\frac{1}{4}$ ", a $4\frac{1}{2}$ " x $2\frac{1}{4}$ " and a 3 " x $1\frac{1}{2}$ " Flat Plate, is attached to a $5\frac{1}{2}$ " x $\frac{1}{2}$ " Double Angle Strip bolted to the sides, and a similar Double

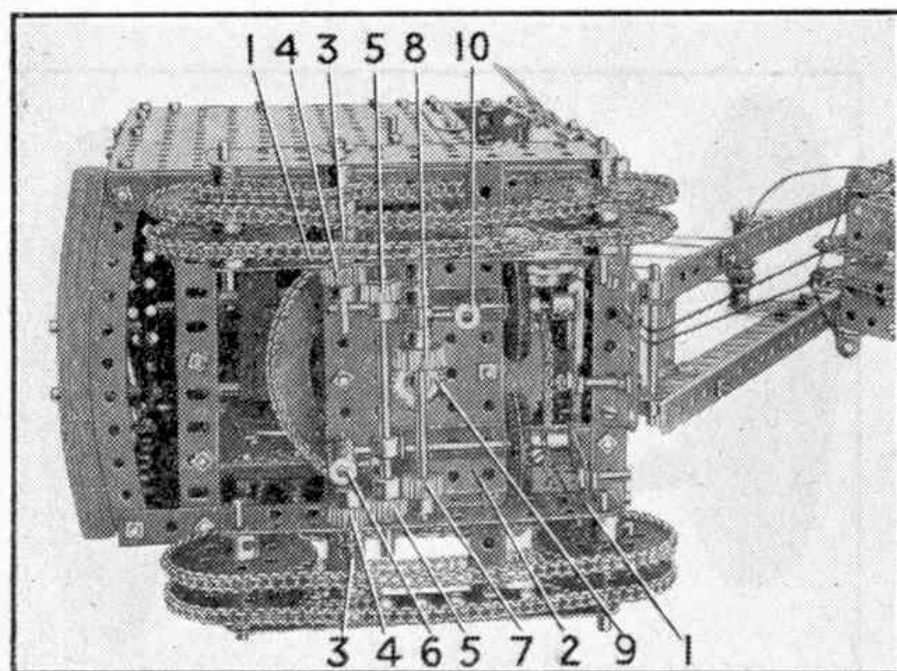

Fig. 2. The construction of the undercarriage of this Meccano mechanical shovel is made clear by this illustration of the actual model.

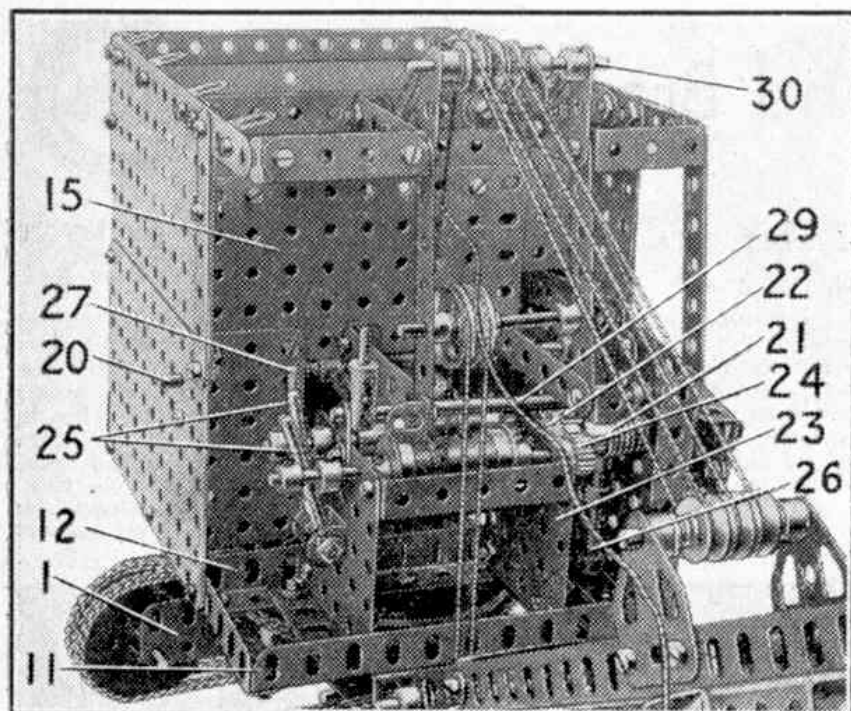

Fig. 3. The mechanism of the shovel is shown here, with the controls for swivelling, luffing and other movements.

Angle Strip 16 (Fig. 4) is also fixed between the sides. The 5" Rod carrying the Contrate 9 is supported at its upper end in Double Angle Strip 16, and is fitted with a $1\frac{1}{2}$ " Bevel 17.

A $\frac{1}{2}$ " Pinion on the Motor shaft meshes with a 57-tooth Gear fixed on a $2\frac{1}{2}$ " Rod mounted in the Motor side-plates. A $\frac{1}{2}$ " Pinion also on this Rod engages a 57-tooth Gear on a $3\frac{1}{2}$ " Rod 18, on which there is also a Worm that is in constant mesh with a $\frac{1}{2}$ " Pinion 19. The Rod 20 of this Pinion is mounted in the sides of the cab, and is fitted with a $\frac{1}{2}$ " Bevel that is in constant mesh with Bevel 17, and outside the cab it carries also a $\frac{3}{4}$ " Sprocket. This Sprocket is linked by Chain to a similar Sprocket fixed on a 2" Rod that is fitted with a Worm 21 and a $\frac{1}{2}$ " Pinion 22. Bearings for the Rod are provided by one side of the cab and by a $2\frac{1}{2}$ " x $2\frac{1}{2}$ " Flat Plate 23 fixed to a $2\frac{1}{2}$ " Angle Girder that is bolted between Girders 11 and 12. The Flat Plate 23 is connected by $2\frac{1}{2}$ " x $\frac{1}{2}$ " Double Angle Strips to a similar Plate supported in a like manner. A casing for the external Sprocket drive is provided by two $4\frac{1}{2}$ " Angle Girders joined by a $4\frac{1}{2}$ " Flat Girder, and attached to the side by Angle Brackets.

Luffing of the boom and the travel of the bucket are controlled from two similar winding drums, each of which consists of a Sleeve Piece fitted with two $\frac{3}{4}$ " Flanged Wheels. The drums are fixed on 4" Rods mounted in the $2\frac{1}{2}$ " x $2\frac{1}{2}$ " Flat Plates, each Rod carrying two Collars and a $\frac{1}{2}$ " Pinion 24. The drive to each drum is engaged by sliding the Rod to bring Pinion 24 into mesh with Pinion 22. Movement of the Rod is controlled by a lever 25, which is a $1\frac{1}{2}$ " Rod fixed in a Rod and Strip Connector lock-nutted to a Double Bracket. The Double Bracket is bolted to one of the $2\frac{1}{2}$ " x $2\frac{1}{2}$ " Flat Plates, and the $1\frac{1}{2}$ " Rod engages between Collars on the winding drum shaft.

The swivelling movement is engaged by sliding a $\frac{1}{2}$ " Pinion into mesh with Worm 21. This Pinion is mounted on a $4\frac{1}{2}$ " Rod 26, which passes at its lower

end through one of the $7\frac{1}{2}$ " Girders of the cab base and at its upper end through a $1" \times \frac{1}{2}"$ Angle Bracket bolted to the side. The Pinion is engaged by moving a lever 27, which consists of a 1" Rod held in a Coupling. The Coupling is fixed on a transverse $4\frac{1}{2}"$ Rod fitted with a Coupling 28 (Fig. 4), and mounted in the $2\frac{1}{2}" \times 2\frac{1}{2}"$ Flat Plates. A $\frac{3}{4}"$ Bolt in Coupling 28 locates between the boss of the Pinion and a Collar on Rod 26. A 1" Sprocket on the same Rod, but below the superstructure, is connected by Chain to the Toothed Disc of the Ball Race.

An arm of the Motor switch is lengthened by a $1\frac{1}{2}"$ Strip, which is linked by a $4\frac{1}{2}"$ Strip to a Crank on Rod 29 (Fig. 3). The Bolts holding the Strip are lock-nutted, and Rod 29 is mounted in one side of the cab and in a Fishplate fixed to one of the $2\frac{1}{2}" \times 2\frac{1}{2}"$ Flat Plates. The control lever is a 1" Rod held in a Coupling.

The boom is made by connecting two $12\frac{1}{2}"$ Angle Girders by two $1\frac{1}{2}" \times \frac{1}{2}"$ Double Angle Strips, and it pivots on a Rod passed through a $1\frac{1}{2}" \times \frac{1}{2}"$ Double Angle Strip bolted to a $2\frac{1}{2}"$ Flat Girder attached to Angle Girder 11. A Flat Trunnion is fixed to each $12\frac{1}{2}"$ Angle Girder, and a Rod mounted in them carries three $\frac{1}{2}"$ loose Pulleys. Three similar Pulleys are slipped over a Rod 30 mounted in $1\frac{1}{2}"$ Corner Brackets fixed to the cab. The luffing Cord is tied to its drum, passed round the sets of $\frac{1}{2}"$ Pulleys and is tied to a Fishplate on Rod 30.

The sides of the bucket are $2\frac{1}{2}" \times 1\frac{1}{2}"$ Flexible Plates joined by $2\frac{1}{2}" \times \frac{1}{2}"$ Double Angle Strips. The top is a $2\frac{1}{2}" \times 2\frac{1}{2}"$ Flat Plate and the bottom is a $2\frac{1}{2}" \times 2\frac{1}{2}"$ Flexible Plate. The trap is a $2\frac{1}{2}" \times 1\frac{1}{2}"$ Flexible Plate to the lower edge of which two 2" Strips are attached by Angle Brackets. To each Strip a similar part is bolted at right angles, these Strips being lock-nutted at their forward ends to a Double Bracket fixed to the top of the bucket. A catch for the trap is provided by three 2" Strips pivoted on a (Cont. on page 478)

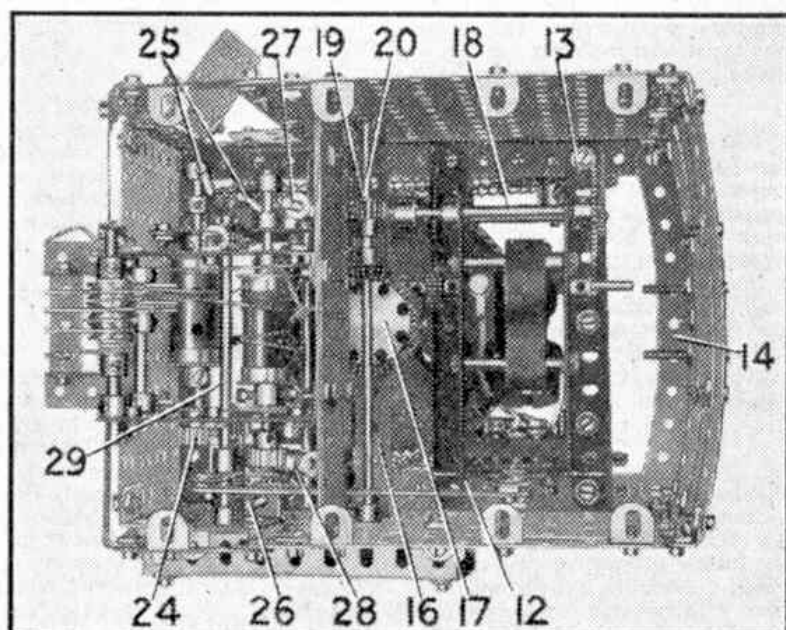

Fig. 4. View looking down into the model before the roof of the cab is fitted, showing the driving mechanism and the Electric Motor.

Petrol Round the World—(Continued from page 436)

interesting to find that the position of these in Great Britain is different from that in the United States and on the Continent. Abroad the oil companies operate road filling stations at which only their own particular blends are available; in Great Britain the filling stations and garages are independent concerns, most of which normally stock the products of more than one of the rival companies.

Filling the tanks of aircraft requires special consideration, and at airfields all over the world the oil companies maintain depots where there are special refuelling vehicles designed to replenish aircraft supplies at high speed. A typical tank car used in refuelling large aircraft has a capacity of 2,500 gallons of aviation spirit, which it can deliver into the tanks at the rate of 400 gallons a minute. A similar service is operated for flying boats, the refuellers used being in effect miniature tankers.

New Meccano Model—

(Continued from page 467)

$\frac{3}{8}$ " Bolt attached by nuts to the bucket side. A $\frac{1}{2}$ " Bolt 31 engages the trap, but is held clear when the operating Cord 35 is hauled in. The bucket guides are two $2\frac{1}{2}$ " Angle Girders on each side. These are bolted together in pairs by their slotted holes, so that a gap wide enough to slide freely over the Angle Girders of the boom is left between their shorter flanges. The guides are attached to $2\frac{1}{2}$ " Flat Girders fixed to the bucket.

The operating Cord is tied to the front of the bucket and passed round a $\frac{1}{2}$ " loose Pulley 32. It is then taken round a $2\frac{1}{2}$ " Rod 33, and over a 1" loose Pulley on $2\frac{1}{2}$ " Rod 34. Then it is passed three or four times round its drum, and led over a second 1" Pulley on Rod 34, under Rod 33 and tied finally at the back of the bucket.

The front of the cab is completed by a $5\frac{1}{2}$ " x $3\frac{1}{2}$ " Flat Plate, and the rear consists of $5\frac{1}{2}$ " x $2\frac{1}{2}$ " Flexible Plates curved to the radius of the $5\frac{1}{2}$ " Curved Strip and attached to the sides by Angle Brackets. The roof is formed by two $5\frac{1}{2}$ " x $2\frac{1}{2}$ " and four $5\frac{1}{2}$ " x $1\frac{1}{2}$ " Flexible Plates, and is fixed to Angle Brackets bolted to the sides.

Stamp Collecting—(Continued from page 473)

Dominica that are seen also on the 12 c. and \$1.20 c., and on the 24 c. values respectively of the present pictorial set. These are Fresh Water Lake and the Boiling Lake, both reminders of the volcanic nature of the island. The first occupies an extinct crater about 3,000 ft. above sea level and is believed by the natives of the island, who have a dread of it, to be bottomless. The boiling lake is actively volcanic.

Of the remaining stamps of the issue the 6 c. value shows the botanical gardens in Roseau, the capital. These cover about 40 acres, in beautiful surroundings, and they are claimed to be the most luxuriant and beautiful of their kind in the West Indies. The lowest value of all, $\frac{1}{2}$ c., is a portrait stamp of H.M. King George VI, similar to the $\frac{1}{4}$ d. stamp of 1940.

Introducing the "Pack Plane"—(Cont. from page 450)

Berlin Air Lift, supplies could have been flown by "Pack Plane" direct from the U.S.A. or Britain to airfields in the Western Sectors of Germany. There the Packs could have been transferred quickly, without unloading, to big helicopters like the XH-16 and ferried to the heart of Berlin. We can only hope that such a major operation will never again be needed; but whatever the future may hold, it seems certain that we shall see a lot more of the "Pack Plane."

By Midland to Manchester—

(Continued from page 440)

Matlock gorge. Before Matlock, where we stop, we pass under High Tor in successive tunnels of that name. Darley Dale is succeeded by Rowsley, an important marshalling centre we are perhaps surprised to find in such striking surroundings.

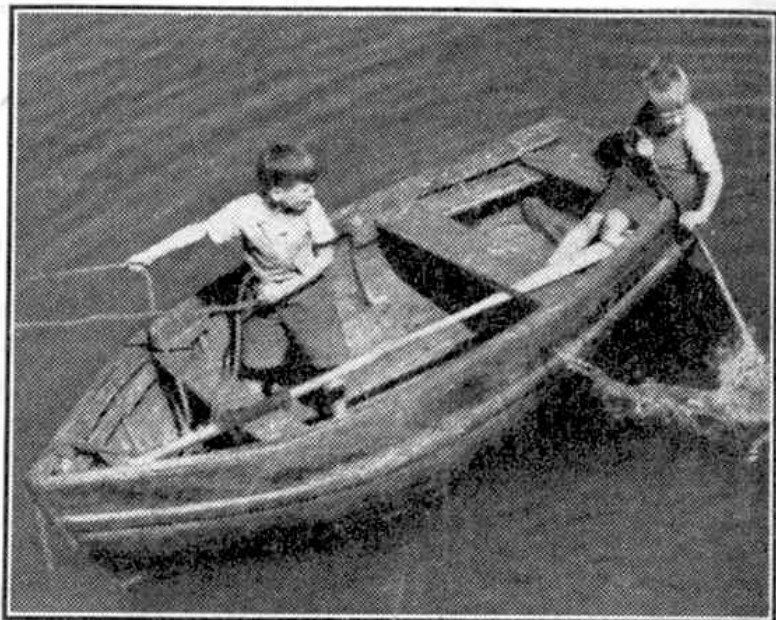

"The Adventurers." This excellent entry from the "M.M." June 1951 Photographic Contest is by L. H. Hobbs, Dartmouth.

Now we part company with the River Derwent, which is succeeded by the Wye. We pass close to romantic Haddon Hall but we do not see it as we have to go through Haddon Tunnel, a covered way provided it is said, to conceal the railway at this point. Up past Bakewell and Great Longstone we climb steadily into the High Peak district. Then with a rush down through Headstone tunnel we are suddenly ushered out into the breath-taking beauty of Monsal Dale and find ourselves high above the River Wye on the graceful arched viaduct pictured on the cover to this issue. Fine views alternate with tunnels over this length especially, as we press on up at 1 in 100 and then stop at Miller's Dale after a short descent at the same inclination. After starting again, practically from Miller's Dale Junction, where the Buxton line goes off, we have a 3-mile stretch at 1 in 90 up to Peak Forest, passing through picturesquely-named Great Rocks Tunnel on the way. Once over the summit we descend, again at 1 in 90, and enter lengthy Dove Holes tunnel cut through solid rock.

Our engine has finished its hard work now for the line falls practically all the way to Manchester. After the Chinley junctions, another triangular layout, another scenic route joins us, the Sheffield line from Dore and Totley. After a smart stop at Chinley station, Buxworth and New Mills are passed and we leave Derbyshire for Cheshire and are soon enveloped in the gloom of Disley Tunnel over 2 miles long.

On leaving it we find the scenery quite different; through the suburbs into busy Lancashire we go, just beyond Cheadle Heath. Finally, easing gently over Throstle Nest Junction, we are led over a viaduct and round the curved approach to Manchester Central, the all-over arched roof of which reminds us of St. Pancras, now 189 $\frac{1}{2}$ miles away.

We regret that we omitted to state that the illustrations to the article "The Tramp and her Work" by Frank C. Bowen in our August issue were by the Nautical Photo. Agency.