

MODEL OF THE MONTH

"Penny-in-the-Slot" Gift Machine

FOR the March "Model of the Month" we have chosen a really novel subject. It is a model based on one of the many different types of "penny-in-the-slot" automatic machines installed at many seaside resorts, and will be found most interesting in construction and capable of providing fun for the younger members

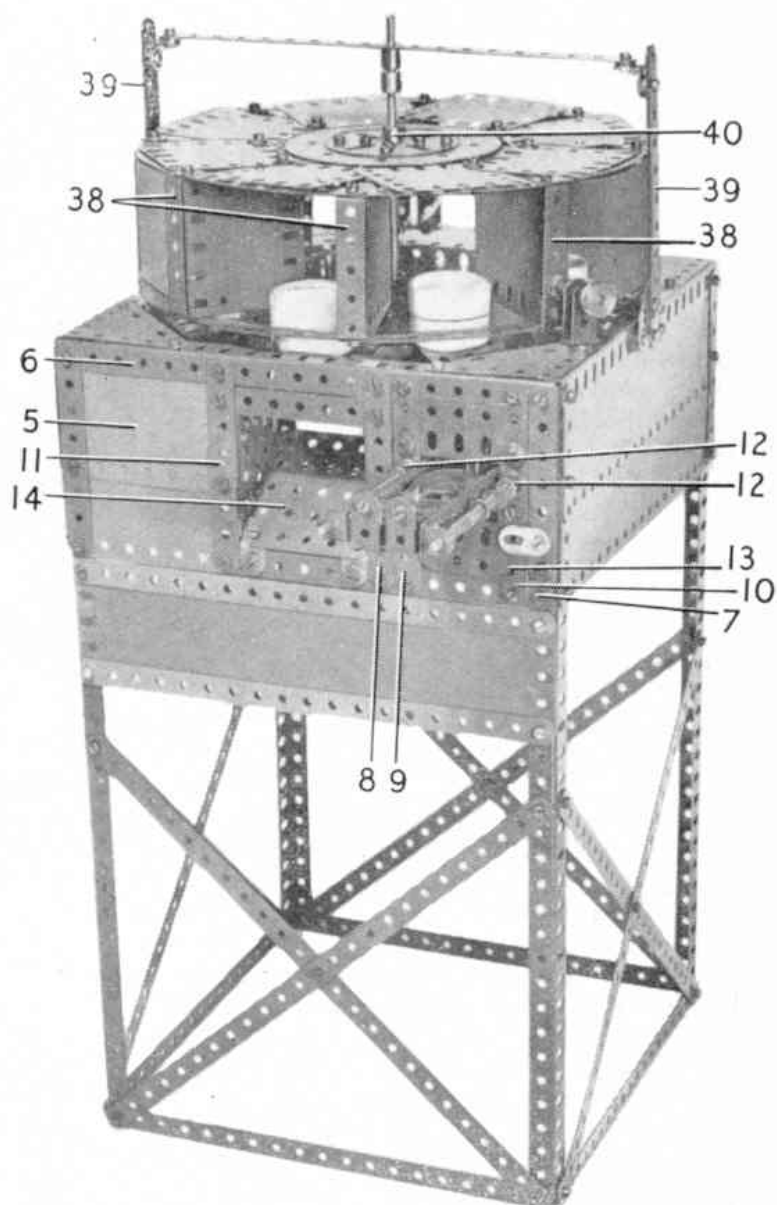
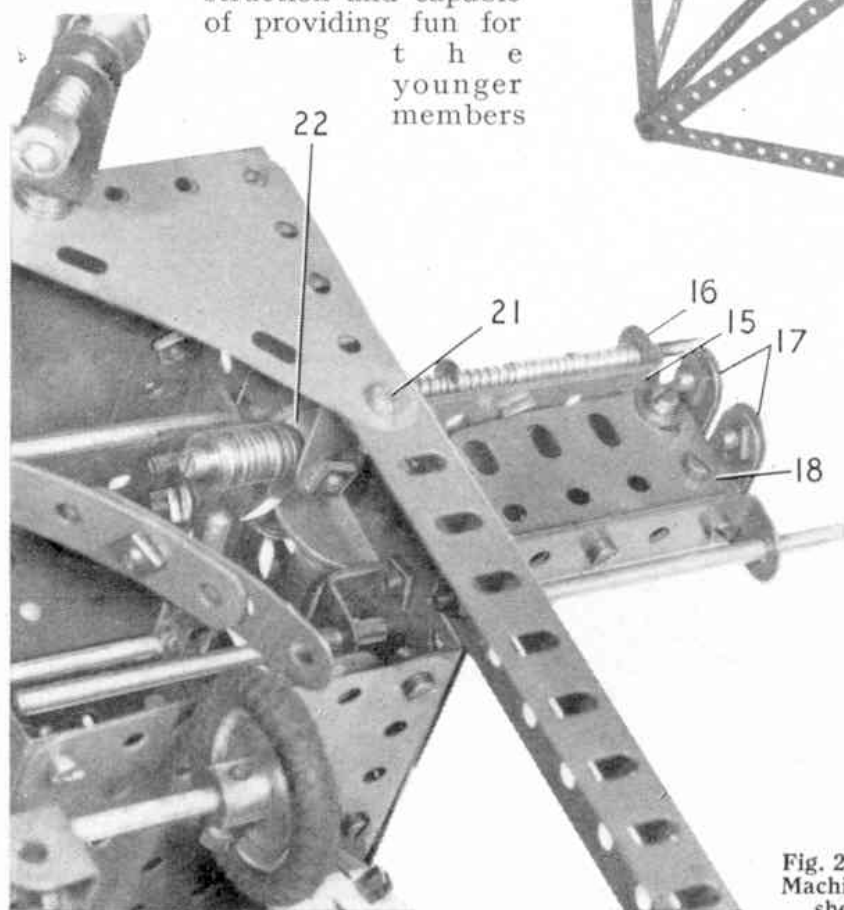

Fig. 1. The Model of the Month—a "Penny-in-the-Slot" Gift Machine.

of the family when it is completed.

The finished model is shown in Fig. 1. It consists essentially of a rotating container mounted on a framework pedestal and divided internally into a number of compartments, in each of which a gift, such as a box of matches, packet of sweets, etc., is placed. Any of these

Fig. 2. This view looking on top of the Gift Machine with the gift container removed, shows the details of the coin drawer.

Fig. 3. A semi-plan view of the Gift Machine, with the container removed to show the eight trays that carry the gifts, and the coin drawer.

gifts can be extracted from the machine simply by first selecting the gift required, rotating the container to a pre-determined point and then placing a penny in a "push-in" drawer provided. When the drawer is pushed in, a release mechanism is set in action and the chosen gift is delivered down a chute at the front of the machine.

The construction of the coin drawer and release mechanism is not difficult and is quite attractive in principle, and the assembly of the model should offer no problems even to young constructors.

As usual full constructional details for building the Automatic Gift Machine can be obtained by any reader and to get them it is only

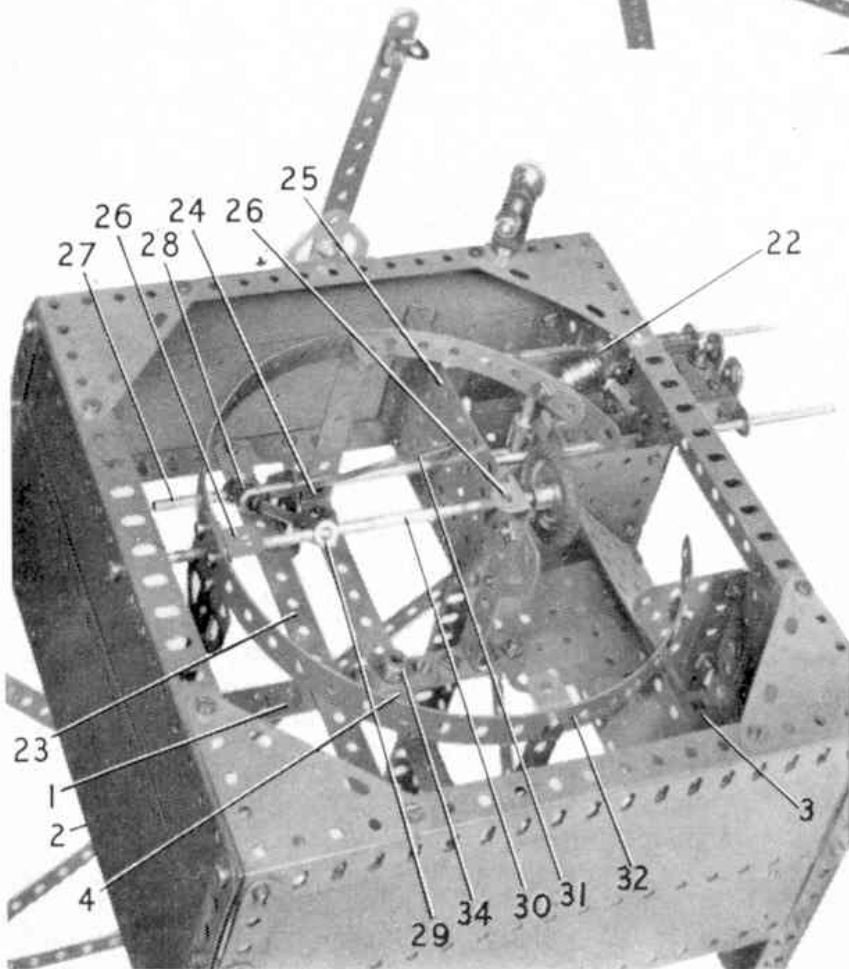
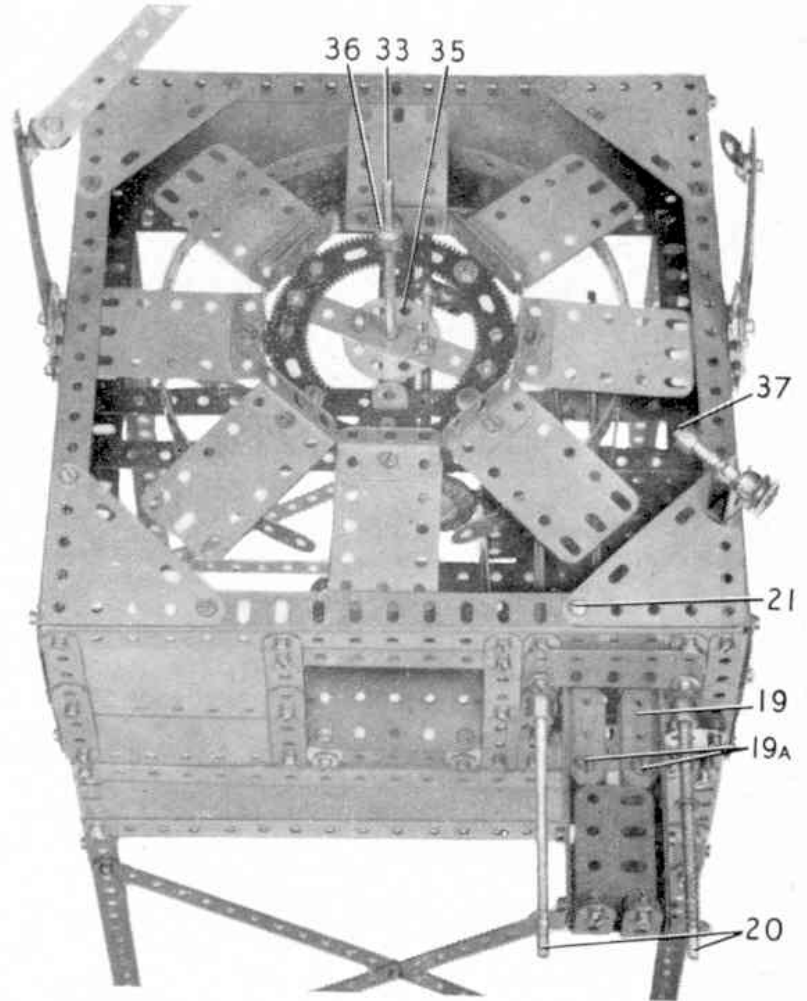

necessary to write to the Editor, Meccano Magazine, Binns Road, Liverpool 13, enclosing a 2d. stamp for postage.

Readers living in Canada, Australia, New Zealand, South Africa, Ceylon, Italy, Rhodesia and the United States of America, should write to our main agents in those countries for their copies of the current "Model of the Month" instructions, also of course enclosing suitable stamps for postage. Write at once and make sure of *your* copy.

Fig. 4. Here can be seen the ring that supports the trays and the release mechanism.

AUTOMATIC PENNY-IN-THE-SLOT GIFT MACHINE

ILLUSTRATED IN THE MARCH 1959 ISSUE OF THE "M.M."

Framework

First build up a square frame with $9\frac{1}{2}$ " Angle Girders, and then connect this to a similar square using four vertical $3\frac{1}{2}$ " Angle Girders, which are attached to the lower frame with Angle Brackets. A $9\frac{1}{2}$ " Angle Girder 1, is bolted to the centres of the Angle Girders 2 and 3, and a $9\frac{1}{2}$ " Strip 4 is fastened in the centres of the other Angle Girders of the lower frame. A Double Arm Crank is now bolted at the point where the Angle Girder 1 crosses the Strip 4. Two $3\frac{1}{2}$ " x $2\frac{1}{2}$ " Flexible Plates 5 are secured to $9\frac{1}{2}$ " Angle Girders 6 and 7 with $2\frac{1}{2}$ " Strips overlapped two holes.

Three built up strips are fixed in positions 8, 9, 10. A $3\frac{1}{2}$ " Strip is secured between the strips 8 and 11. To the Strips 9 and 10 a $2\frac{1}{2}$ " Flat Girder and two Cranks 12 are bolted. A 2" Flat Girder 13 is hinged to the built up strip 9, and a $2\frac{1}{2}$ " x $2\frac{1}{2}$ " Flat Plate 14 is attached to the Angle Girder 7 by Obtuse Angle Brackets. On each side of this Plate 14 a 2" x $2\frac{1}{2}$ " Flexible Triangular Plate is secured to a 2" Angle Girder, and bolted to the strips 8 and 11. The other three sides of the framework are filled in with $9\frac{1}{2}$ " x $2\frac{1}{2}$ " Strip Plates, edged by $2\frac{1}{2}$ " Strips. To each bottom corner of the top frame a $12\frac{1}{2}$ " Angle Girder is attached. These are braced with crossed $12\frac{1}{2}$ " Strips and four $9\frac{1}{2}$ " Strips are bolted to their lower ends. Two further $9\frac{1}{2}$ " Strips, and a $9\frac{1}{2}$ " x $2\frac{1}{2}$ " Strip Plate are fixed in place as shown at the front of the machine.

The Coin Drawer and its Mechanism

To a $3\frac{1}{2}$ " Angle Girder 15 a $3\frac{1}{2}$ " x $\frac{1}{2}$ " Double Angle Strip 16 is bolted and this is joined to a similar unit with a 2" Flat Girder and two 1" x 1" Angle Brackets 17, leaving a space of $\frac{3}{16}$ " between the bottom of the Angle Girders 15. Another 2" Flat Girder 18 is bolted to the 1" x 1" Angle Brackets 17 with $\frac{1}{2}$ " x $\frac{1}{2}$ " Angle Brackets. Nine $1\frac{1}{2}$ " Strips 19 are bolted to each side of the $3\frac{1}{2}$ " Angle Girders with $\frac{1}{2}$ " Bolts 19a. Two $6\frac{1}{2}$ " Rods 20 are placed in the Cranks 12, with the drawer in position, having one lug of the $3\frac{1}{2}$ " x $2\frac{1}{2}$ " Double Angle Strips inside. Five Compression Springs with Washers are placed as shown on one of the Rods 20, to bring the drawer back into place. A $\frac{1}{2}$ " x 1" Angle Bracket is fixed to the $9\frac{1}{2}$ " Angle Girder with Bolt 21 and to it is secured a Pawl and Pivot Bolt 22, which has a $\frac{3}{4}$ " Bolt, loaded as shown with Washers, in its boss. When a coin is inserted in the drawer and the drawer is pushed in the coin will push the Pawl forward. When the drawer is completely in, the Pawl will swing behind the coin, thus dragging it off the slide when the drawer is released. The Pawl can be adjusted in the slot of the $\frac{1}{2}$ " x 1" Angle Bracket.

Now bolt a $9\frac{1}{2}$ " Strip 23 to the $9\frac{1}{2}$ " Angle Girders and a Trunnion 24 in the position indicated. A $3\frac{1}{2}$ " x $2\frac{1}{2}$ " Flanged Plate 25 is attached to a $5\frac{1}{2}$ " x $2\frac{1}{2}$ " Flat Plate with a $2\frac{1}{2}$ " Angle Girder, and a $2\frac{1}{2}$ " x $2\frac{1}{2}$ " Flat Plate is bolted to the $3\frac{1}{2}$ " x $2\frac{1}{2}$ " Flanged Plate to form the coin box. Four $3\frac{1}{2}$ " x $\frac{1}{2}$ " Double Angle Strips are secured to the $9\frac{1}{2}$ " Angle Girders and the $9\frac{1}{2}$ " Strip 4 and two Flat Trunnions are bolted to the Double Angle Strips 26. A $6\frac{1}{2}$ " Rod 27 is passed through the Trunnion 24 and the Flanged Plate 25. A Coupling and a 1" Rod are secured to the Rod 27, and a further Coupling 28 attached to Rod 27 is connected with a 3" Rod to Coupling 29 on Rod 30, which has a 1" Pulley with Tyre secured on its inner end. The Rod 30 is pulled back into position with a Driving Band 31 fastened to the 3" Rod. A $1\frac{1}{2}$ " Rod anchors the end of the Driving Band after passing through the Plate 25. Two $9\frac{1}{2}$ " Strips 32 extended by 2" Slotted Strips, are bent to form a circle with a gap at the front as shown and are then bolted to the $3\frac{1}{2}$ " x $2\frac{1}{2}$ " Double Angle Strips.

The Hinged Gift Trays

To a Gear Ring, eight Hinges equally spaced apart are bolted, and each Hinge has a $1\frac{1}{2}$ " Angle Girder and a $2\frac{1}{2}$ " x $1\frac{1}{2}$ " Flexible Plate bolted to it. Across the centre of the Gear Ring a $3\frac{1}{2}$ " Strip carrying a Bush Wheel 35 is attached. The tray unit is mounted on an 8" Rod 33 passed through the Double Arm Crank 34. When it is in place the hinged trays are held horizontal by the circular strip 32, except the one at the front which is located over the gap in the circular strip and is held up by the 1" Pulley with Tyre. When the drawer is pushed in carrying a coin, the Pulley slides to the centre, allowing the tray to drop on the Plate 14 and deliver whatever gift it may be carrying down the chute.

The gift container part of the machine is completed by bolting to a Face Plate four $4\frac{1}{2}$ " and four $3\frac{1}{2}$ " Angle Girders alternately, and then fixing to their ends eight 4" Curved Strips and eight $2\frac{1}{2}$ " x $\frac{1}{2}$ " Double Angle Strips 38. The top of the gift container is a similar unit built from a Face Plate, a 4" Circular Plate, four $4\frac{1}{2}$ " Angle Girders and four $3\frac{1}{2}$ " Angle Girders. Eight 4" Curved Strips are bolted to the top lugs of the Double Angle Strips and eight $2\frac{1}{2}$ " x $2\frac{1}{2}$ " Flexible Plates are then bolted to the vertical flange of the top Angle Girders to form eight gift compartments. Another eight $2\frac{1}{2}$ " x $2\frac{1}{2}$ " Flexible Plates bolted in place on the top of the gift container complete this section of the model with the exception of a strip of thin plastic or celluloid sheet $2\frac{1}{2}$ " wide and 30" long, which is placed around the container between the Double Angle Strips and the outer edges of the $2\frac{1}{2}$ " x $2\frac{1}{2}$ " Flexible Plates forming the compartment walls.

A Collar 36 is secured to the Rod 33 in such a position that it will support the container at such a height that the spring loaded Rod 37 will project into the second hole up the Double Angle Strips 38 of the container.

The Face Plate 40 is secured to the Rod 33 with the hinged trays in the centre of the compartments between the Double Angle Strips 38. The Rod 33 is extended by a Rod Socket and an Adaptor for Screwed Rod. A $9\frac{1}{2}$ " Strip is bolted to the $5\frac{1}{2}$ " Strips 39 with Hinges. Flat Trunnions support the Strips 39 and are spaced away from the $9\frac{1}{2}$ " Angle Girders by Washers. To operate the machine, first withdraw the Rod 37 from the Double Angle Strips 38 and then turn the gift container until the selected gift is at the front of the machine. The Rod 37 is then released and placed in the hole of the Double Angle Strip opposite the Rod 37. A coin is placed in the coin drawer, the drawer is pushed right in and then released. The selected gift will then fall down the discharge chute, and the machine is ready for another customer.

Parts required to build the Automatic Penny-in-the-Slot Gift Machine:-

8 of No. 1; 11 of No. 1a; 4 of No.2; 4 of No.3; 20 of No. 5; 18 of No. 6a;
4 of No. 8; 9 of No. 8a; 4 of No. 9a; 7 of No. 9b; 1 of No. 9d; 2 of No. 9e;
8 of No. 9f; 1 of No. 10; 11 of No. 12; 2 of No. 12a; 1 of No. 12b; 2 of No. 12c;
1 of No. 13a; 4 of No. 14; 1 of No. 16b; 2 of No. 18a; 1 of No. 18b; 1 of No. 22;
1 of No. 23a; 1 of No. 24; 208 of No. 37a; 196 of No. 37b; 72 of No. 38;
8 of No. 48a; 6 of No. 48b; 1 of No. 53; 2 of No. 55a; 4 of No. 59; 2 of No. 62;
1 of No. 62b; 3 of No. 63; 1 of No. 70; 2 of No. 72; 16 of No. 89b; 1 of No. 102;
1 of No. 103f; 3 of No. 103g; 1 of No. 109; 4 of No. 111a; 6 of No. 111c;
1 of No. 111d; 11 of No. 114; 6 of No. 120b; 1 of No. 126; 4 of No. 126a;
1 of No. 142c; 1 of No. 146a; 1 of No. 147; 1 of No. 173a; 1 of No. 179;
1 of No. 180; 1 of No. 186a; 8 of No. 188; 16 of No. 190; 2 of No. 190a;
7 of No. 196; 2 of No. 222; 4 of No. 223.