

Special Meccano Model

Tunnel Excavator

THIS new model, which is specially designed for experienced model-builders with a good collection of parts at their disposal, is based on an actual tunnelling machine manufactured by the Distington Engineering Co. Ltd., Workington. It is known as the Distington-Goodman Tunneller, and is specially designed and constructed for working in small bore tunnels. The model is fitted with an E20R type Electric Motor and is shown complete in Fig. 1.

Each side of the chassis consists of two $12\frac{1}{2}$ " Angle Girders joined by Fishplates to form channel section girders, and the sides are connected at each end by two $3\frac{1}{2}$ " Angle Girders. The wheels are $1\frac{1}{8}$ " Flanged Wheels fixed on $4\frac{1}{2}$ " Rods mounted in the slotted holes of the lower pair of $12\frac{1}{2}$ " Angle Girders, as shown in Fig. 2, the Rods being held in position by Collars fixed inside the Angle Girders. The Collars are fitted with $7/64$ " Grub Screws, and the standard Grub Screws must be removed as otherwise their projecting heads will foul the flanges of the Girders. A 57-tooth Gear 1 is fixed on the rear axle.

Collars 2, fitted with Threaded Pins, are placed over the protruding ends of each axle, and a Compression Spring is slipped over each Threaded Pin as shown in Fig. 3. The upper ends of the Threaded Pins are free to slide in Angle Brackets bolted to $9\frac{1}{2}$ " Angle Girders fixed to the chassis, and the locking nuts are tightened against the Collars so that the Threaded Pins do not grip the axles. Each Collar is spaced from the chassis by two Washers.

Each side of the model is made by bolting a $1\frac{1}{2}$ " Strip 3 and $1\frac{1}{2}$ " Angle Girder 4 to the $9\frac{1}{2}$ " Angle Girder fixed to the chassis. The upper ends of parts 3 and 4 are connected by a further $9\frac{1}{2}$ " Angle Girder 5, and the space between them is filled by $5\frac{1}{2} \times 1\frac{1}{2}$ " Flexible Plates. The side is extended by a $5\frac{1}{2}$ " Angle Girder 6 bolted to Girder 5, which supports a $5\frac{1}{2} \times 1\frac{1}{2}$ " Flexible Plate and a $2\frac{1}{2} \times 2\frac{1}{2}$ " Flat Plate 7.

These Plates are edged by Strips as shown in Fig. 1, and $3\frac{1}{2}$ " Angle Girders 8 are bolted to the upper corners of Plates 7.

The model is driven by an E20R Electric Motor bolted direct to the rear of the chassis. The $\frac{1}{2}$ " Pinion on the Motor shaft engages a 57-tooth Gear 9, fixed on a $3\frac{1}{2}$ " Rod 10 (Fig. 3). The bearings for Rod 10 are provided by a $3\frac{1}{2} \times \frac{1}{2}$ " Double Angle Strip 11 bolted across the chassis, and by a $2\frac{1}{2} \times \frac{1}{2}$ " Double Angle Strip 12. Double Angle Strip 12 is bolted to a flange of the Motor side-plate, and to

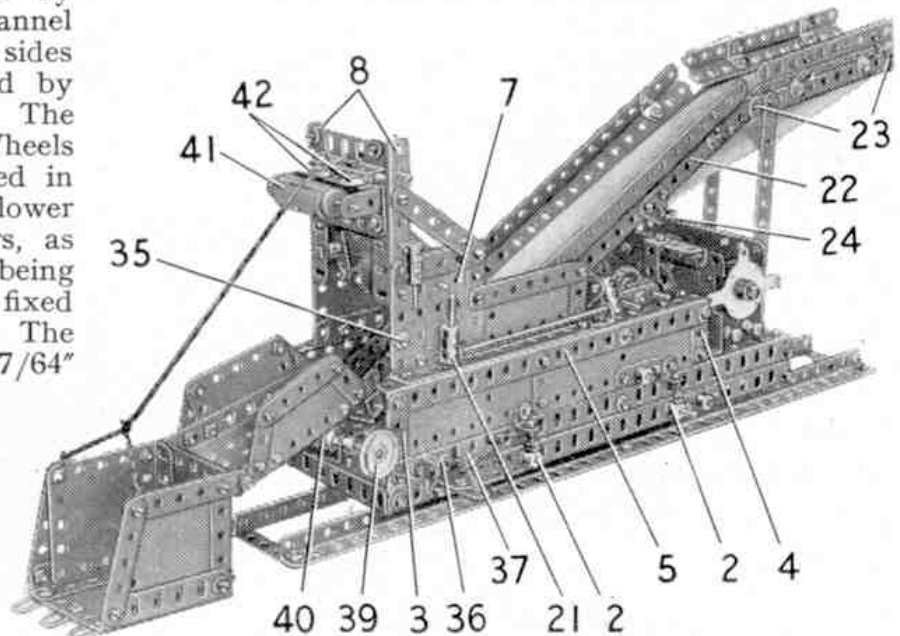

Fig. 1. A general view of the Tunnel Excavator, with the bucket lowered ready for loading.

a $1\frac{1}{2}$ " Angle Girder fixed to the side-plate.

Rod 10 is fitted with a Worm 13 that is in constant mesh with a $\frac{1}{2}$ " Pinion on a $3\frac{1}{2}$ " Rod 14. This Rod is free to turn in $1\frac{1}{2}$ " Angle Girders bolted to Girders 5, and it carries a 1" Gear 15 and a $\frac{1}{2}$ " Pinion 16. An intermediate Pinion 17 is free to turn on a $\frac{3}{4}$ " Bolt fixed to one of the $1\frac{1}{2}$ " Girders by two nuts, and this Pinion is in constant mesh with a further $\frac{1}{2}$ " Pinion on a Rod 18. The latter Rod carries also a $\frac{3}{4}$ " Sprocket and a 1" Gear, and the Sprocket is connected by Chain to a similar Sprocket on a Rod 19. Rod 19 is located in the slotted holes of the chassis by $1\frac{1}{2}$ " Strips, and a $\frac{1}{2}$ " Pinion on the Rod engages the 57-tooth Gear 1 on the rear axle.

The drive in forward and reverse directions is engaged by sliding Rod 14 to

bring the appropriate gears into mesh. The sliding movement of the Rod is controlled by a $\frac{3}{4}$ " Bolt fixed by two nuts to a Double Arm Crank 20. The Double Arm Crank is free to pivot on a $\frac{1}{2}$ " Bolt lock-nutted to Double Angle Strip 11, and a $1\frac{1}{2}$ " Strip slipped over the $\frac{3}{4}$ " Bolt is pivoted on a Bolt locked in a Coupling. The Coupling is fixed on a 5" Rod mounted in Angle Brackets, and the operating lever is a Coupling 21 fitted with a 1" Rod (Fig. 1).

The main section of the conveyor consists of $12\frac{1}{2}$ " Strips 22, connected by two $1\frac{1}{2} \times \frac{1}{2}$ " Double Angle Strips. Two further $12\frac{1}{2}$ " Strips on each side are joined together by Obtuse Angle Brackets and are also connected to the Strips 22 by Obtuse Angle Brackets. The short horizontal section of the conveyor is assembled in the same way as the main section, using $5\frac{1}{2}$ " Strips in place of $12\frac{1}{2}$ " Strips, and the sections are joined by $2\frac{1}{2}$ " Curved Strips as shown in Fig. 1.

The conveyor belt is supported by four rollers. Two of these are indicated at 23, and consist of 2" Rods fitted with Collars and a Coupling. The third roller, which is marked 24, is a $2\frac{1}{2}$ " Rod and it is mounted

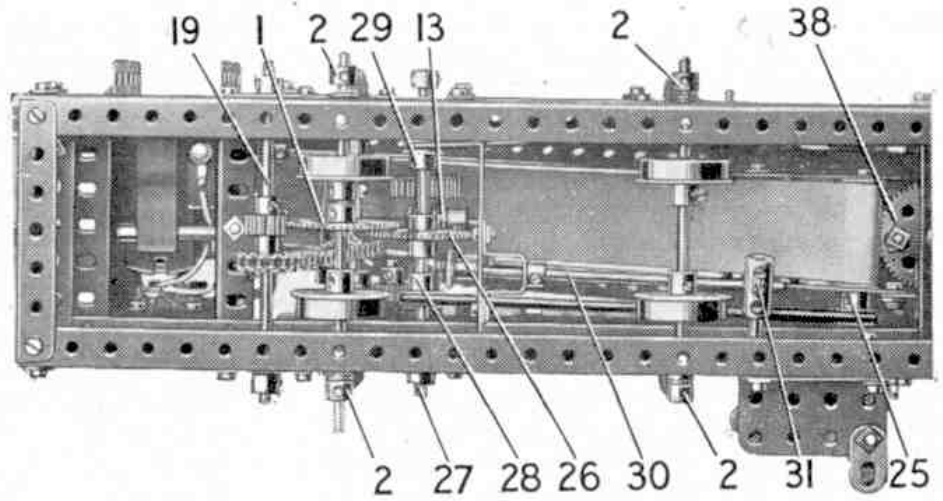

Fig. 2. This underneath view shows the drive to the conveyor belt and the bucket-operating hoist.

in 1" Triangular Plates and held in position by Spring Clips. The fourth roller is used to drive the belt, and it is a $2\frac{1}{2}$ " Rod mounted in the next-to-end lower holes in the Strips 22. Two Collars and a Coupling are fixed on the Rod, and a $\frac{1}{2}$ " Pulley 25 is also locked in position. A short length of adhesive tape is wrapped round the roller to increase the friction between it and the belt. The belt is made by placing a strip of stout paper round the rollers and then gluing the ends together. The complete unit is attached to the front of the chassis by a Corner Angle Bracket and it is supported at the rear by two $5\frac{1}{2}$ " Strips bolted to $1 \times \frac{1}{2}$ " Angle Brackets.

The drive to the conveyor is engaged by sliding a 57-tooth Gear 26 into mesh with the Worm 13. Gear 26 is carried on a $4\frac{1}{2}$ " Rod 27 mounted across the chassis, and the Rod is fitted with $\frac{1}{2}$ " Pulleys 28 and 29. Pulley 28 is linked by twin Driving Bands to the Pulley 25. The sliding movement of Rod 27 is controlled by a Double Arm Crank fixed on a Rod 30. The Rod is mounted in a $3\frac{1}{2} \times \frac{1}{2}$ " Double Angle Strip bolted across the chassis, and in a Double Bent Strip fixed to the Double Angle Strip. A Bolt in the Double Arm Crank engages between Pulley 28 and a Collar, and a Coupling 31 on Rod 30 is fitted with a $1\frac{1}{2}$ " Rod that projects through a slotted hole in the chassis. The $1\frac{1}{2}$ " Rod carries a Rod and Strip Connector

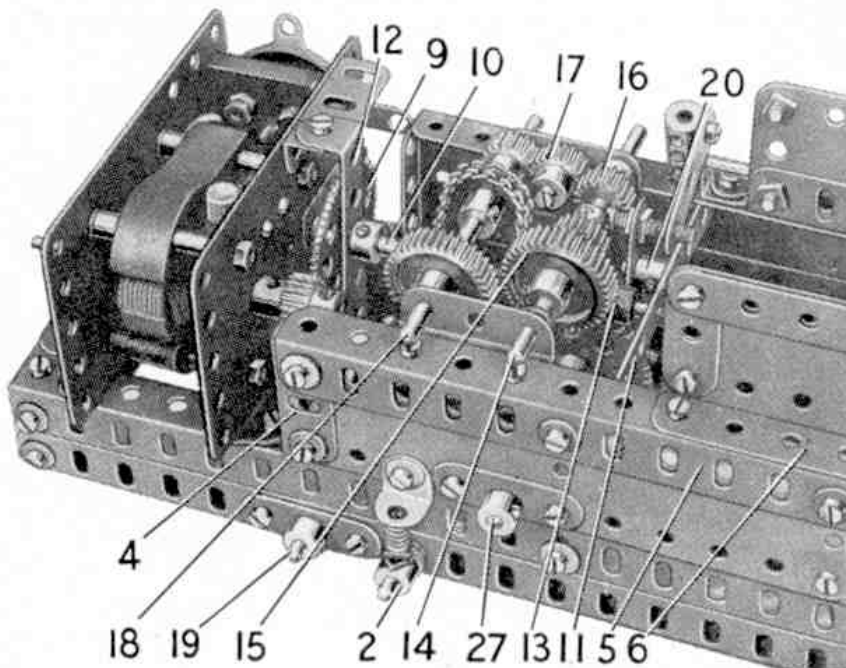

Fig. 3. The tunnelling machine with the conveyor removed to show the Electric Motor and the main drive reversing mechanism.

that represents a foot-operated pedal.

The drive to the drum operating the digger bucket is taken by a Driving Band from Pulley 29 to a 1" Pulley 32 (Fig. 4) on a $3\frac{1}{2}$ " Rod mounted in the Flat Plates 7. A $\frac{3}{4}$ " Pinion is also fixed on this Rod, and the drive to the drum shaft is engaged by sliding a 50-tooth Gear into mesh with this Pinion. The Gear is fixed on the drum shaft, which carries also a $1\frac{1}{2}$ " Pulley 33 and two $\frac{3}{4}$ " Flanged Wheels that form the drum. The lever controlling the winding movement is a 1" Rod held in a Coupling on a Rod 34. This Rod is connected by a Rod and Strip Connector to a Double Arm Crank that is free to pivot on a Bolt lock-nutted to one of the Girders 8. A Bolt in the Double Arm Crank engages between the 50-tooth Gear and a Collar.

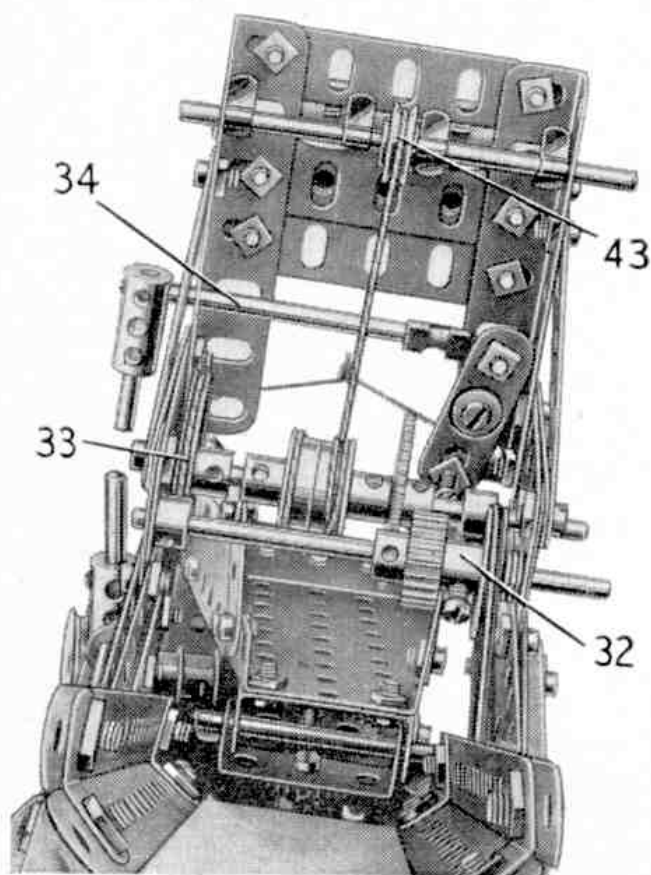

Fig. 4. A detail view of the drum that operates the bucket hoist and the gear drive to the hoisting shaft.

A brake on the drum shaft is provided by a length of Cord fastened to one of the Flat Plates 7 by a bolt 35, then taken through a hole in the Plate and passed round the Pulley 33. The Cord is tied at its lower end to a Spring Clip on a $1\frac{1}{2}$ " Rod fixed in a Collar 36. The Collar is pivoted by a bolt to an Angle Bracket bolted to the chassis, and a Rod and Strip Connector 37 fitted to the Rod carries a Threaded Pin. A Compression Spring is

slipped over the Threaded Pin, and it bears against a Fishplate bolted to a Girder Bracket that represents the operator's footplate. The Compression Spring keeps the Cord taut round the Pulley 33 unless the pedal is depressed.

The sides of the digger bucket are $2\frac{1}{2}$ " \times $2\frac{1}{2}$ " Flexible Plates, and its bottom and back are formed by similar parts. The Flexible Plates are connected together by $2\frac{1}{2}$ " and 3" Angle Girders as shown, and they are edged by $2\frac{1}{2}$ " and 3" Strips. The bucket is lock-nutted by $\frac{3}{8}$ " Bolts to the wider end of a Flanged Sector Plate fitted with sides formed by $2\frac{1}{2}$ " \times $1\frac{1}{2}$ " Flexible Plates strengthened by Strips, as shown in Fig. 1. A $1\frac{1}{2}$ " \times $\frac{1}{2}$ " Double Angle Strip is bolted to the narrow end of the Flanged Sector Plate, and a 2" Rod is passed through the lugs of this Double Angle Strip and a similar part bolted tightly to a 57-tooth Gear 38 (Fig. 2). The 2" Rod is held in place by Spring Clips.

A 2" Rod is fixed in the boss of Gear 38, then passed through the $3\frac{1}{2}$ " Angle Girders of the chassis and retained in position by a Collar. The bucket can be slewed from side to side by turning a hand-wheel 39. This is fixed on a $2\frac{1}{2}$ " Rod that carries a Worm 40. The Rod is mounted in a $1\frac{1}{2}$ " \times $\frac{1}{2}$ " Double Angle Strip bolted at a slight angle to a Semi-Circular Plate fixed to the front of the chassis. The Worm engages the 57-tooth Gear 38.

A length of Cord is tied to the bucket, and passes over a roller 41 and between two $\frac{1}{2}$ " loose Pulleys 42. It then passes over a $\frac{1}{2}$ " loose Pulley 43 and is tied to the winding drum. The roller 41 consists of a Sleeve Piece and two Chimney Adaptors, and it is free on a Rod held by Spring Clips in a $2\frac{1}{2}$ " \times 1" Double Angle Strip bolted to the Girders 8. The Pulleys 42 are loosely held on $\frac{1}{2}$ " Bolts passed through $2\frac{1}{2}$ " Angle Girders fixed to the Girders 8. Pulley 43 is free to turn on a Rod mounted as shown in Fig. 4.

Parts required to build the model Tunnel Excavator:
 6 of No. 1; 8 of No. 2; 2 of No. 3; 4 of No. 4; 7 of No. 5;
 15 of No. 6a; 4 of No. 8; 4 of No. 8a; 2 of No. 9; 6 of
 No. 9b; 2 of No. 9c; 4 of No. 9d; 5 of No. 9f; 8 of No. 10;
 7 of No. 12; 2 of No. 12b; 16 of No. 12c; 2 of No. 15;
 4 of No. 15a; 6 of No. 16; 2 of No. 16a; 2 of No. 16b;
 5 of No. 17; 2 of No. 18a; 2 of No. 18b; 4 of No. 20;
 2 of No. 20b; 1 of No. 21; 2 of No. 22; 3 of No. 23;
 3 of No. 23a; 1 of No. 25; 5 of No. 26; 1 of No. 27;
 4 of No. 27a; 2 of No. 31; 2 of No. 32; 13 of No. 35;
 166 of No. 37; 20 of No. 37a; 65 of No. 38; 4 of No. 38d;
 1 of No. 40; 1 of No. 45; 1 of No. 46; 6 of No. 48; 1 of
 No. 48a; 2 of No. 48b; 1 of No. 54; 26 of No. 59; 3 of
 No. 62b; 7 of No. 63; 2 of No. 72; 2 of No. 77; 2 of No.
 90; 1 of No. 94; 2 of No. 96a; 1 of No. 103f; 4 of No. 111;
 5 of No. 111a; 5 of No. 111c; 5 of No. 115; 5 of No. 120b;
 1 of No. 154a; 1 of No. 161; 1 of No. 163; 2 of No. 164;
 3 of No. 186b; 2 of No. 188; 6 of No. 189; 4 of No. 190
 3 of No. 212; 1 of No. 214; 1 E20R Electric Motor.